

Контроллеры автономные серии Trajexia MC02

ТЕХНИЧЕСКИЕ ХАРАКТЕРИСТИКИ

По вопросам продаж и поддержки обращайтесь:

Архангельск (8182)63-90-72
Астана +7(7172)727-132
Белгород (4722)40-23-64
Брянск (4832)59-03-52
Владивосток (423)249-28-31
Волгоград (844)278-03-48
Вологда (8172)26-41-59
Воронеж (473)204-51-73
Екатеринбург (343)384-55-89
Иваново (4932)77-34-06
Ижевск (3412)26-03-58
Казань (843)206-01-48

Калининград (4012)72-03-81
Калуга (4842)92-23-67
Кемерово (3842)65-04-62
Киров (8332)68-02-04
Краснодар (861)203-40-90
Красноярск (391)204-63-61
Курск (4712)77-13-04
Липецк (4742)52-20-81
Магнитогорск (3519)55-03-13
Москва (495)268-04-70
Мурманск (8152)59-64-93
Набережные Челны (8552)20-53-41

Нижний Новгород (831)429-08-12
Новокузнецк (3843)20-46-81
Новосибирск (383)227-86-73
Орел (4862)44-53-42
Оренбург (3532)37-68-04
Пенза (8412)22-31-16
Пермь (342)205-81-47
Ростов-на-Дону (863)308-18-15
Рязань (4912)46-61-64
Самара (846)206-03-16
Санкт-Петербург (812)309-46-40
Саратов (845)249-38-78

Смоленск (4812)29-41-54
Сочи (862)225-72-31
Ставрополь (8652)20-65-13
Тверь (4822)63-31-35
Томск (3822)98-41-53
Тула (4872)74-02-29
Тюмень (3452)66-21-18
Ульяновск (8422)24-23-59
Уфа (347)229-48-12
Челябинск (351)202-03-61
Череповец (8202)49-02-64
Ярославль (4852)69-52-93

Trajexia stand-alone

2.5 axes motion controller

Stand-alone motion controller for compact and simple machines

- Perfect motion control of 2 axes
Supports position, speed and torque control
Serial port for master encoder axis
Multi-tasking controller capable of running up to 22 tasks simultaneously
2 fast-registration inputs
Single axis moves and axes interpolation
Electronic cams and gearboxes
Motion basic programming and dedicated motion commands
Open communication: Serial and EtherNet/IP built-in, PROFIBUS-DP, DeviceNet and CANopen options



System configuration

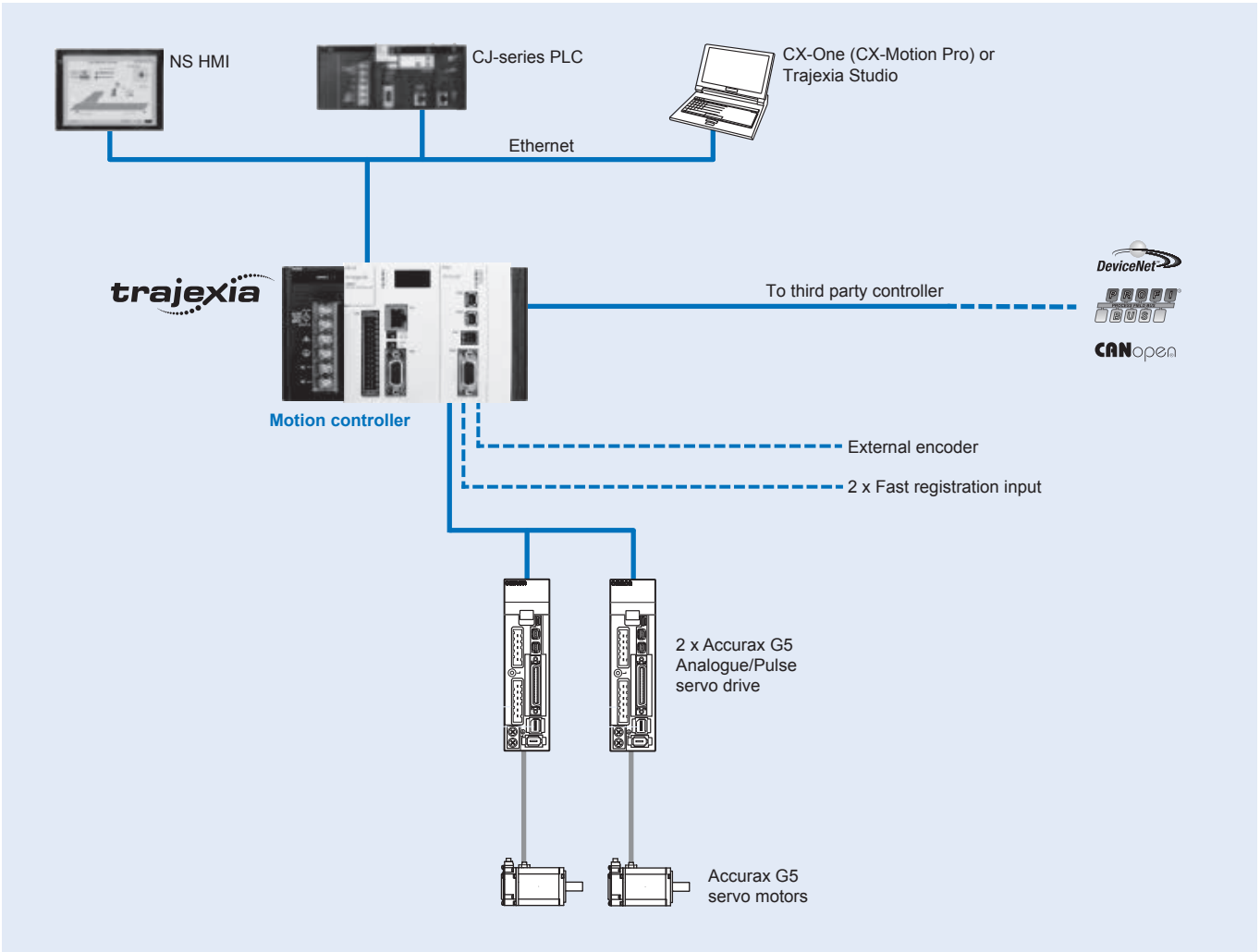

Trajexia general specifications

Item	Details
Model	TJ@
Ambient operating temperature	0 to 55°C
Ambient operating humidity	10 to 90% RH (with no condensation)
Ambient storage temperature	-20 to 70°C (excluding battery)
Ambient storage humidity	90% max. (with no condensation)
Atmosphere	No corrosive gases
Vibration resistance	10 to 57 Hz: (0.075 mm amplitude) 57 to 100 Hz acceleration: 9.8 m/s ² in X, Y and Z directions for 80
Shock resistance	147 m/s ² , 3 times each X, Y and Z directions
Insulation resistance	20 MΩ
Dielectric strength	500 VAC
Protective structure	IP20
International standards	CE, EN 61131-2, cULus, Lloyds, RoHS compliant

Trajexia motion controller unit

Item	Details
Model	TJ2-MC02
Power supply	5 VDC and 24 VDC (supplied by a power supply unit)
Total power consumption	3.1 W
Current consumption	620 mA at 5 VDC
Weight	230 g
Number of real axes	3
Real time clock	Yes
Servo period	0.25 ms, 0.5 ms, 1 ms or 2 ms
Programming language	BASIC-like motion language
Multi-tasking	Up to 22 BASIC programs
Digital I/O	16 digital inputs and 8 digital outputs, freely configurable
Measurement units	User-definable
Available memory for user programs	8 MB
Data storage capacity	Up to 32 MB Flash data storage
Saving program data	RAM and Flash-ROM memory backup Battery backup
Saving program data on the PC	Trajexia Studio software manages backups on the hard-disk of the PC
Communication connectors	1 Ethernet connection and 2 serial connections
Firmware update	Via Trajexia Studio / CX-Motion Pro software
Electrical characteristics of the Ethernet interface	Conforms to IEEE 802.3 (100BaseT)
Ethernet supported protocols	TELNET, FINS server and client, Modbus TCP slave and EtherNet/IP slave

G5 interface unit

Item	Details
Model	TJ2-KS02
Power supply	5 VDC and 24 VDC
Total power consumption	1.5 W to 3.7 W (output PS maximum load)
Current consumption	5 VDC: 110 mA 24 VDC: 20 to 110 mA (output PS maximum load)
Weight	83 g
Galvanic isolation	Encoder interface and digital interface
Output power supply	5 VDC, 250 mA maximum
Number of axes	3 (2 axes + 1 master encoder axis)
Control method	2 axes for Position, Speed and Torque control 1 axis for Pulse Train output in Open Loop
Encoder position/speed feedback	Incremental and absolute
Absolute encoder standards supported	S S I E n D a t
SSI specification	Maximum supported number of bits: 25 Gray and binary encoding Multiples of 2 ⁿ Clock frequency: 200 kHz
EnDat specification	Compatible with version 2.1 and 2.2 Maximum supported number of bits: 32 Clock frequency: 1 MHz
Servo period	0.5 ms when using Accurax G5-A/P Servo Drives 0.25 ms, 0.5 ms, 1 ms, 2 ms Note: 0.25 ms not supported by the absolute encoder interfaces.
Encoder input maximum frequency	6 MHz
Encoder/pulse output maximum frequency	2 MHz
Maximum cable length	Accurax G5 interface, 3 m SSI, 100 m EnDat, 40 m Encoder/stepper input, 100 m Encoder/stepper output, 100 m
Auxiliary I/Os	Two fast registration inputs

Nomenclature

Trajexia motion controller unit (TJ2-MC02)

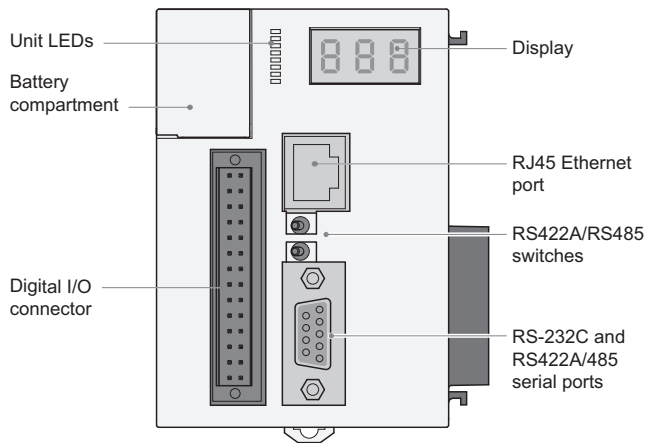

G5 interface unit (TJ2-KS02)

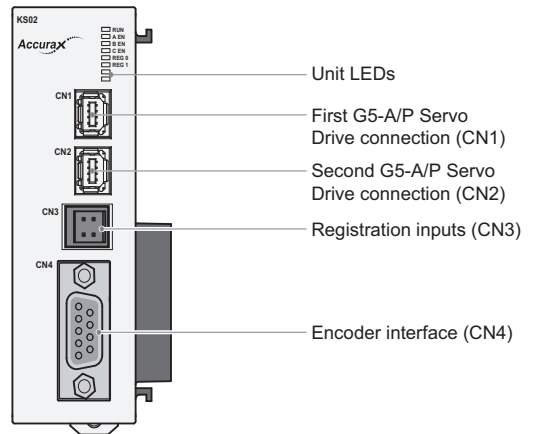

Dimensions

Trajexia system (CJ1W-PA202 + TJ2-MC02 + TJ2-KS02 + TJ1-TER)

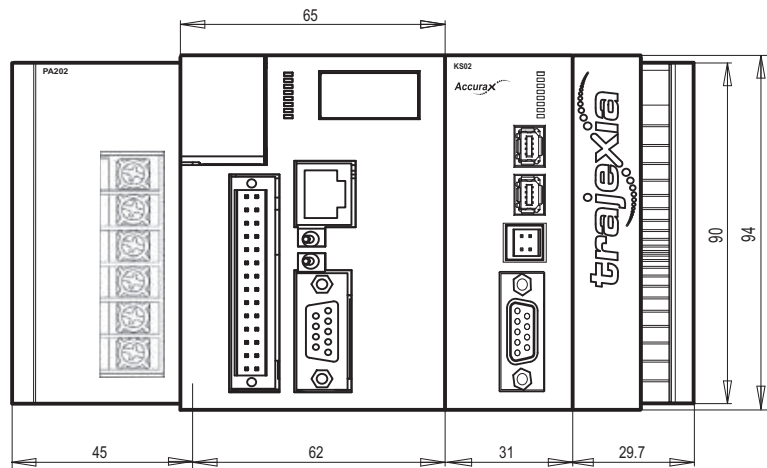

Trajexia motion controller unit (TJ2-MC02)

G5 interface unit (TJ2-KS02)

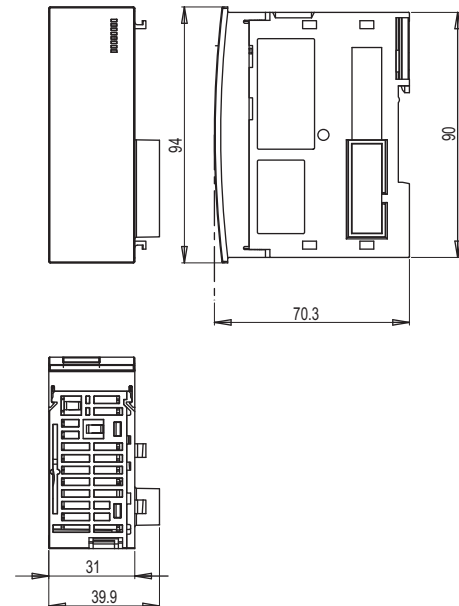
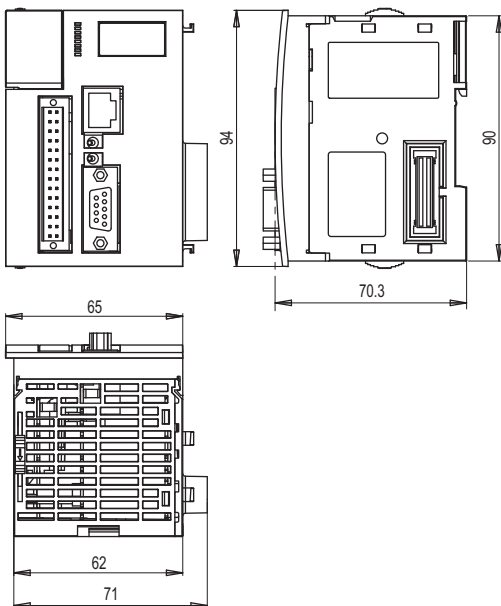

Ordering information

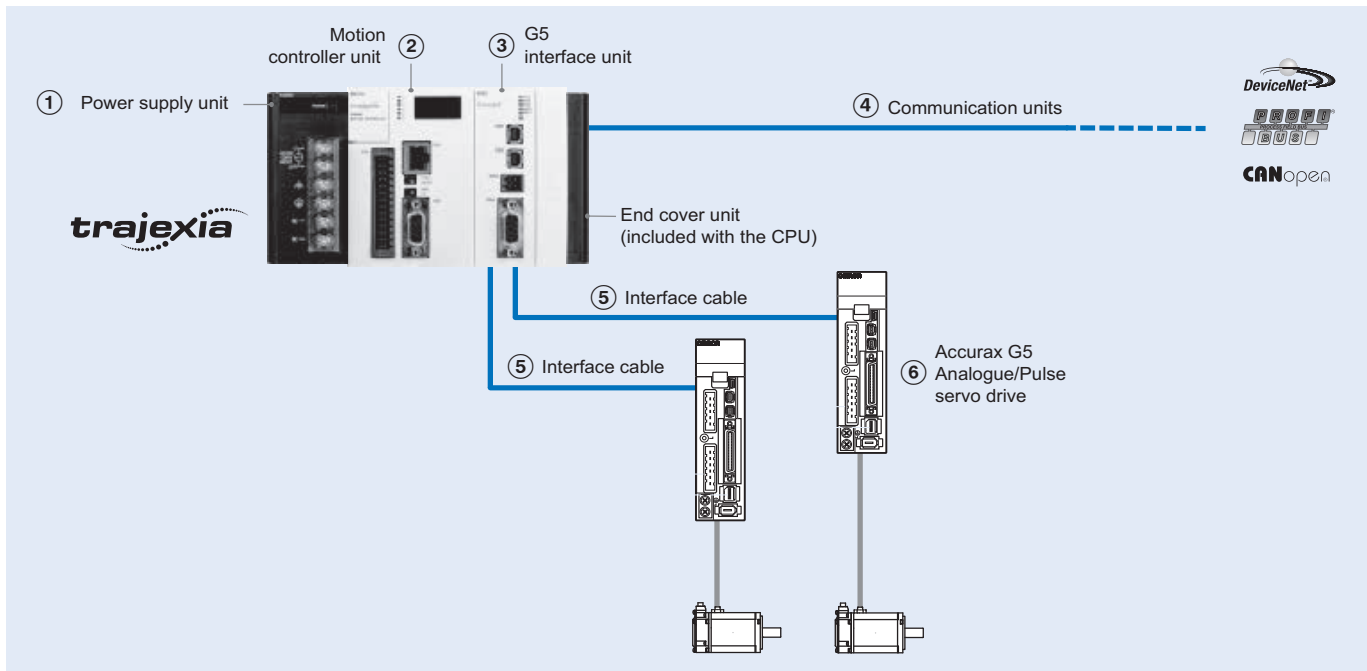

Trajexia system

Power supply unit

Symbol	Specifications	Model
A	Power supply unit for Trajexia system (100-240 VAC)	CJ1W-PA202
	Power supply unit for Trajexia system (24 VDC)	CJ1W-PD025

Motion controller unit

Symbol	Specifications	Model
B	Trajexia motion controller unit, up to 64 axes (Trajexia end cover unit TJ1-TER is included)	TJ2-MC64
	Trajexia motion controller unit, up to 2 axes (Trajexia end cover unit TJ1-TER is included)	TJ2-MC02

G5 interface unit

Symbol	Specifications	Model
C	G5 interface unit	TJ2-KS02

Communication unit

Symbol	Specifications	Model
D	Trajexia DeviceNet slave unit	TJ1-DRT
	Trajexia PROFIBUS-DP slave unit	TJ1-PRT
	Trajexia CANopen unit	TJ1-CORT

Note 1: The TJ2-MC02 supports a maximum of one TJ1-CORT unit.

Note 2: The TJ2-MC02 supports a maximum of one TJ1-PRT or TJ1-DRT unit. No both at the same time.

Accessories

Symbol	Specifications	Model	
E	Interface cable	1 m	TJ2-KC01M
		3 m	TJ2-KC03M

Servo drive related device

Symbol	Specifications	Model
F	Accurax G5 Analogue/Pulse servo drive (100 W-15 kW)	R88D-KT@

Computer software

Specifications	Model
CX-Motion Pro (version 1.4.2 or higher)	CX-One
Trajexia Studio* (version 1.4.2 or higher)	TJ1-Studio

*When the Trajexia Studio software is included in CX-One, then it is called CX-Motion Pro.

ALL DIMENSIONS SHOWN ARE IN MILLIMETERS.
To convert millimeters into inches, multiply by 0.03937. To convert grams into ounces, multiply by 0.03527.

По вопросам продаж и поддержки обращайтесь:

Архангельск (8182)63-90-72
Астана +7(7172)727-132
Белгород (4722)40-23-64
Брянск (4832)59-03-52
Владивосток (423)249-28-31
Волгоград (844)278-03-48
Вологда (8172)26-41-59
Воронеж (473)204-51-73
Екатеринбург (343)384-55-89
Иваново (4932)77-34-06
Ижевск (3412)26-03-58
Казань (843)206-01-48

Калининград (4012)72-03-81
Калуга (4842)92-23-67
Кемерово (3842)65-04-62
Киров (8332)68-02-04
Краснодар (861)203-40-90
Красноярск (391)204-63-61
Курск (4712)77-13-04
Липецк (4742)52-20-81
Магнитогорск (3519)55-03-13
Москва (495)268-04-70
Мурманск (8152)59-64-93
Набережные Челны (8552)20-53-41

Нижний Новгород (831)429-08-12
Новокузнецк (3843)20-46-81
Новосибирск (383)227-86-73
Орел (4862)44-53-42
Оренбург (3532)37-68-04
Пенза (8412)22-31-16
Пермь (342)205-81-47
Ростов-на-Дону (863)308-18-15
Рязань (4912)46-61-64
Самара (846)206-03-16
Санкт-Петербург (812)309-46-40
Саратов (845)249-38-78

Смоленск (4812)29-41-54
Сочи (862)225-72-31
Ставрополь (8652)20-65-13
Тверь (4822)63-31-35
Томск (3822)98-41-53
Тула (4872)74-02-29
Тюмень (3452)66-21-18
Ульяновск (8422)24-23-59
Уфа (347)229-48-12
Челябинск (351)202-03-61
Череповец (8202)49-02-64
Ярославль (4852)69-52-93