

# Сервоприводы серии Sigma-5

## ТЕХНИЧЕСКИЕ ХАРАКТЕРИСТИКИ

**По вопросам продаж и поддержки обращайтесь:**

Архангельск (8182)63-90-72  
Астана +7(7172)727-132  
Белгород (4722)40-23-64  
Брянск (4832)59-03-52  
Владивосток (423)249-28-31  
Волгоград (844)278-03-48  
Вологда (8172)26-41-59  
Воронеж (473)204-51-73  
Екатеринбург (343)384-55-89  
Иваново (4932)77-34-06  
Ижевск (3412)26-03-58  
Казань (843)206-01-48

Калининград (4012)72-03-81  
Калуга (4842)92-23-67  
Кемерово (3842)65-04-62  
Киров (8332)68-02-04  
Краснодар (861)203-40-90  
Красноярск (391)204-63-61  
Курск (4712)77-13-04  
Липецк (4742)52-20-81  
Магнитогорск (3519)55-03-13  
Москва (495)268-04-70  
Мурманск (8152)59-64-93  
Набережные Челны (8552)20-53-41

Нижний Новгород (831)429-08-12  
Новокузнецк (3843)20-46-81  
Новосибирск (383)227-86-73  
Орел (4862)44-53-42  
Оренбург (3532)37-68-04  
Пенза (8412)22-31-16  
Пермь (342)205-81-47  
Ростов-на-Дону (863)308-18-15  
Рязань (4912)46-61-64  
Самара (846)206-03-16  
Санкт-Петербург (812)309-46-40  
Саратов (845)249-38-78

Смоленск (4812)29-41-54  
Сочи (862)225-72-31  
Ставрополь (8652)20-65-13  
Тверь (4822)63-31-35  
Томск (3822)98-41-53  
Тула (4872)74-02-29  
Тюмень (3452)66-21-18  
Ульяновск (8422)24-23-59  
Уфа (347)229-48-12  
Челябинск (351)202-03-61  
Череповец (8202)49-02-64  
Ярославль (4852)69-52-93

# Sigma-5 servo drive

The High performance servo family for motion control. Compact size, reduced space and integrated MECHATROLINK-II.

- Advance autotuning function
- Enhanced vibration suppression function
- Standard support for analog voltage/pulse train reference series or MECHATROLINK-II communications reference series
- Support for direct drive servomotors, linear servomotors and linear sliders
- Integrated safety stop function
- Oscilloscope available via software tool
- Windows based configuration and commissioning software



### Ratings

- 230 VAC Single-phase 50 W to 1.5 kW (4.77 Nm)
- 400 VAC Three-phase 500 W to 15 kW (95.4 Nm)

## System configuration

(Refer to chapter Sigma-II rotary motors)

**SGMAH, SGMPH Servo Motor**      **SGMGH, SGMUH, SGMSh, SGMbH Servo Motor**

(Refer to chapter Sigma-5 rotary motors)

**SGMJV, SGMV, SGMV Servo Motor**      **SGMGV, SGMV Servo Motor**

(Refer to chapter Sigma linear motors)







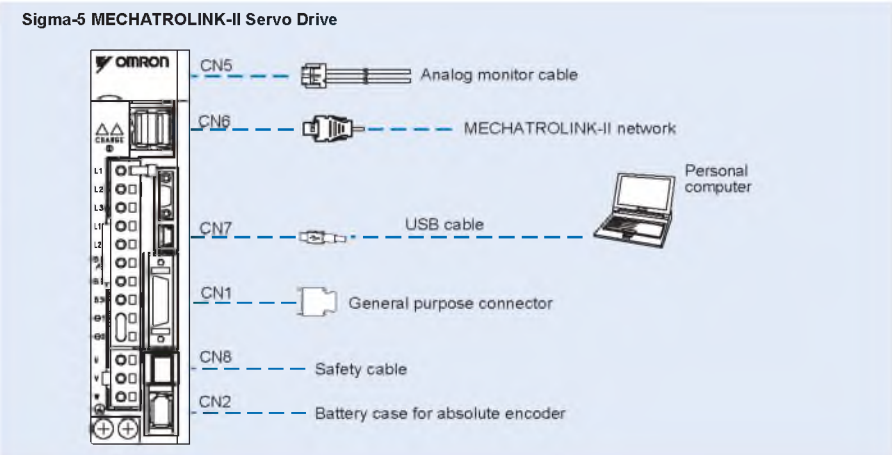
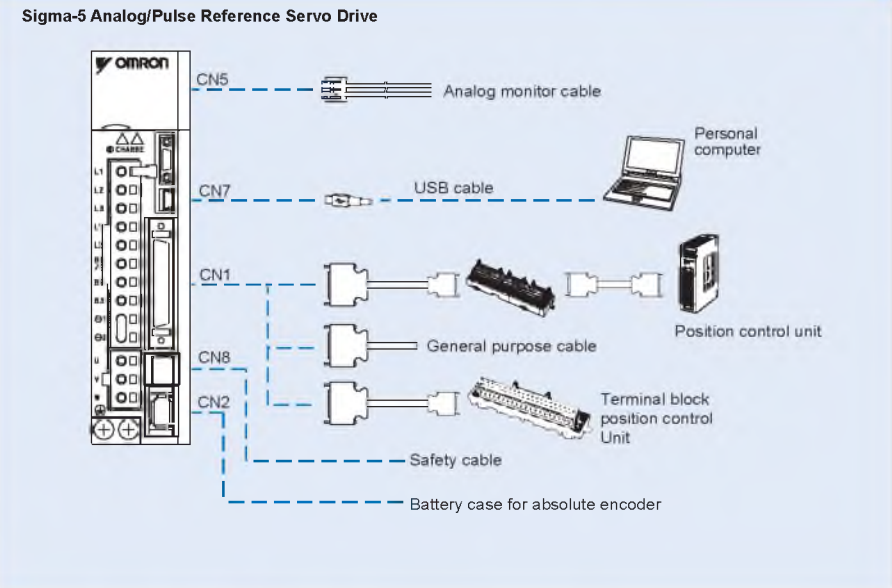

**SGLG\_linear Servo Motor**      **SGLF\_linear Servo Motor**      **SGLT\_linear Servo Motor**







(Refer to chapter Sigma direct drive motors)

**Direct drive servo motor SGMCS-@-@B, C, D, E**      **Direct drive servo motor SGMCS-@-@M, N**



Servo motor / servo drive combination

Servo motor				Sigma-5 Servo drive				
Family	Voltage	Rated torque	Capacity	230 V (1 phase) Analog/Pulse	230 V (1 phase) MECHATROLINK-II	400 V (3 phase) Analog/Pulse	400 V (3 phases) MECHATROLINK-II	
<b>Sigma-II series motors (refer to the Sigma-II rotary motors chapter for details)</b>								
 SGMAH (3000 min <sup>-1</sup> )	230 V	0.0955 Nm	30 W	SGDV-R70A01A	SGDV-R70A11A	-	-	
		0.159 Nm	50 W	SGDV-R70A01A	SGDV-R70A11A	-	-	
		0.318 Nm	100 W	SGDV-R90A01A	SGDV-R90A11A	-	-	
		0.637 Nm	200 W	SGDV-1R6A01A	SGDV-1R6A11A	-	-	
		1.27 Nm	400 W	SGDV-2R8A01A	SGDV-2R8A11A	-	-	
		2.39 Nm	750 W	SGDV-5R5A01A	SGDV-5R5A11A	-	-	
	400 V	0.955 Nm	300 W	-	-	SGDV-1R9D01A	SGDV-1R9D11A	
		2.07 Nm	650 W	-	-	SGDV-3R5D01A	SGDV-3R5D11A	
 SGMPH (3000 min <sup>-1</sup> )	230 V	0.0955 Nm	30 W	SGDV-R90A01A	SGDV-R90A11A	-	-	
		0.637 Nm	200 W	SGDV-1R6A01A	SGDV-1R6A11A	-	-	
		1.27 Nm	400 W	SGDV-2R8A01A	SGDV-2R8A11A	-	-	
		2.39 Nm	750 W	SGDV-5R5A01A	SGDV-5R5A11A	-	-	
		4.77 Nm	1500 W	SGDV-120A01A008000	SGDV-120A11A008000	-	-	
	400 V	0.637 Nm	200 W	-	-	SGDV-1R9D01A	SGDV-1R9D11A	
			1.27 Nm	400 W	-	-	SGDV-1R9D01A	SGDV-1R9D11A
		2.39 Nm	750 W	-	-	SGDV-3R5D01A	SGDV-3R5D11A	
		4.77 Nm	1500 W	-	-	SGDV-5R4D01A	SGDV-5R4D11A	
 SGMGH (1500 min <sup>-1</sup> )	400 V	2.84 Nm	0.45 kW	-	-	SGDV-1R9D01A	SGDV-1R9D11A	
		5.39 Nm	0.85 kW	-	-	SGDV-3R5D01A	SGDV-3R5D11A	
		8.34 Nm	1.3 kW	-	-	SGDV-5R4D01A	SGDV-5R4D11A	
		11.5 Nm	1.8 kW	-	-	SGDV-8R4D01A	SGDV-8R4D11A	
		18.6 Nm	2.9 kW	-	-	SGDV-120D01A	SGDV-120D11A	
		28.4 Nm	4.4 kW	-	-	SGDV-170D01A	SGDV-170D11A	
		35.0 Nm	5.5 kW	-	-	SGDV-210D01A	SGDV-210D11A	
		48.0 Nm	7.5 kW	-	-	SGDV-260D01A	SGDV-260D11A	
		70.0 Nm	11 kW	-	-	SGDV-280D01A	SGDV-280D11A	
		95.4 Nm	15 kW	-	-	SGDV-370D01A	SGDV-370D11A	
 SGMSH (3000 min <sup>-1</sup> )	400 V	3.18 Nm	1.0 kW	-	-	SGDV-3R5D01A	SGDV-3R5D11A	
		4.90 Nm	1.5 kW	-	-	SGDV-5R4D01A	SGDV-5R4D11A	
		6.36 Nm	2.0 kW	-	-	SGDV-8R4D01A	SGDV-8R4D11A	
		9.80 Nm	3.0 kW	-	-	SGDV-120D01A	SGDV-120D11A	
		12.6 Nm	4.0 kW	-	-	SGDV-170D01A	SGDV-170D11A	
 SGMUH (6000 min <sup>-1</sup> )	400 V	1.59 Nm	1.0 kW	-	-	SGDV-3R5D01A	SGDV-3R5D11A	
		2.45 Nm	1.5 kW	-	-	SGDV-5R4D01A	SGDV-5R4D11A	
		4.9 Nm	3.0 kW	-	-	SGDV-120D01A	SGDV-120D11A	
		6.3 Nm	4.0 kW	-	-	SGDV-170D01A	SGDV-170D11A	
<b>Sigma-5 series motors (refer to the Sigma-5 rotary motors chapter for details)</b>								
 SGMJV (3000 min <sup>-1</sup> )	230 V	0.159 Nm	50 W	SGDV-R70A01A	SGDV-R70A11A	-	-	
		0.318 Nm	100 W	SGDV-R90A01A	SGDV-R90A11A	-	-	
		0.637 Nm	200 W	SGDV-1R6A01A	SGDV-1R6A11A	-	-	
		1.27 Nm	400 W	SGDV-2R8A01A	SGDV-2R8A11A	-	-	
		2.39 Nm	750 W	SGDV-5R5A01A	SGDV-5R5A11A	-	-	
 SGMAV (3000 min <sup>-1</sup> )	230 V	0.159 Nm	50 W	SGDV-R70A01A	SGDV-R70A11A	-	-	
		0.318 Nm	100 W	SGDV-R90A01A	SGDV-R90A11A	-	-	
		0.477 Nm	150 W	SGDV-1R6A01A	SGDV-1R6A11A	-	-	
		0.637 Nm	200 W	SGDV-1R6A01A	SGDV-1R6A11A	-	-	
		1.27 Nm	400 W	SGDV-2R8A01A	SGDV-2R8A11A	-	-	
		1.75 Nm	550 W	SGDV-5R5A01A	SGDV-5R5A11A	-	-	
		2.39 Nm	750 W	SGDV-5R5A01A	SGDV-5R5A11A	-	-	
 SGMEV (3000 min <sup>-1</sup> )	230 V	3.18 Nm	1.0 kW	SGDV-120A01A008000	SGDV-120A11A008000	-	-	
		0.0955 Nm	30 W	SGDV-R90A01A	SGDV-R90A11A	-	-	
		0.637 Nm	200 W	SGDV-1R6A01A	SGDV-1R6A11A	-	-	
		1.27 Nm	400 W	SGDV-2R8A01A	SGDV-2R8A11A	-	-	
		2.39 Nm	750 W	SGDV-5R5A01A	SGDV-5R5A11A	-	-	
	4.77 Nm	1.5 kW	SGDV-120A01A008000	SGDV-120A11A008000	-	-		
	400 V	0.637 Nm	200 W	-	-	SGDV-1R9D01A	SGDV-1R9D11A	
			0.955 Nm	300 W	-	-	SGDV-1R9D01A	SGDV-1R9D11A
			1.27 Nm	400 W	-	-	SGDV-1R9D01A	SGDV-1R9D11A
		2.07 Nm	650 W	-	-	SGDV-3R5D01A	SGDV-3R5D11A	
		2.39 Nm	750 W	-	-	SGDV-3R5D01A	SGDV-3R5D11A	
		4.77 Nm	1.5 kW	-	-	SGDV-5R4D01A	SGDV-5R4D11A	

Servo motor				Sigma-5 Servo drive			
Family	Voltage	Rated torque	Capacity	230 V (1 phase) Analog/Pulse	230 V (1 phase) MECHATROLINK-II	400 V (3 phase) Analog/Pulse	400 V (3 phases) MECHATROLINK-II
 SGMGV (1500 min <sup>-1</sup> )	400 V	1.96 Nm	300 W	-	-	SGDV-1R9D01A	SGDV-1R9D11A
		2.86 Nm	450 W	-	-	SGDV-1R9D01A	SGDV-1R9D11A
		5.39 Nm	850 W	-	-	SGDV-3R5D01A	SGDV-3R5D11A
		8.34 Nm	1.3 kW	-	-	SGDV-5R4D01A	SGDV-5R4D11A
		11.5 Nm	1.8 kW	-	-	SGDV-8R4D01A	SGDV-8R4D11A
		18.6 Nm	2.9 kW	-	-	SGDV-120D01A	SGDV-120D11A
		28.4 Nm	4.4 kW	-	-	SGDV-170D01A	SGDV-170D11A
		35.0 Nm	5.5 Kw	-	-	SGDV-210D01A	SGDV-210D11A
		48.0 Nm	7.5 Kw	-	-	SGDV-260D01A	SGDV-260D11A
		70.0 Nm	11 Kw	-	-	SGDV-280D01A	SGDV-280D11A
 SGMSV (3000 min <sup>-1</sup> )	400 V	3.18 Nm	1 kW	-	-	SGDV-3R5D01A	SGDV-3R5D11A
		4.9 Nm	1.5 kW	-	-	SGDV-5R4D01A	SGDV-5R4D11A
		6.36 Nm	2 kW	-	-	SGDV-8R4D01A	SGDV-8R4D11A
		7.96 Nm	2.5 kW	-	-	SGDV-120D01A	SGDV-120D11A
		9.8 Nm	3 kW	-	-	SGDV-120D01A	SGDV-120D11A
		12.6 Nm	4 kW	-	-	SGDV-170D01A	SGDV-170D11A
		15.8 Nm	5 kW	-	-	SGDV-170D01A	SGDV-170D11A
<b>Sigma direct drive motors (refer to the Sigma direct drive motors chapter for details)</b>							
 SGMCS (200 min <sup>-1</sup> )	230 V	2.0 Nm	42 W	SGDV-2R8A01A	SGDV-2R8A11A	-	-
		5.0 Nm	105 W	SGDV-2R8A01A	SGDV-2R8A11A	-	-
		7.0 Nm	147 W	SGDV-1R6A01A	SGDV-1R6A11A	-	-
		4.0 Nm	84 W	SGDV-2R8A01A	SGDV-2R8A11A	-	-
		10.0 Nm	209 W	SGDV-2R8A01A	SGDV-2R8A11A	-	-
		14.0 Nm	293 W	SGDV-2R8A01A	SGDV-2R8A11A	-	-
		8.0 Nm	168 W	SGDV-2R8A01A	SGDV-2R8A11A	-	-
		17.0 Nm	356 W	SGDV-2R8A01A	SGDV-2R8A11A	-	-
		25.0 Nm	393 W	SGDV-2R8A01A	SGDV-2R8A11A	-	-
		16.0 Nm	335 W	SGDV-5R5A01A	SGDV-5R5A11A	-	-
		35.0 Nm	550 W	SGDV-5R5A01A	SGDV-5R5A11A	-	-
		45.0Nm	707 W	SGDV-120A01A008000	SGDV-120A11A008000	-	-
		80.0 Nm	1260 W	SGDV-120A01A008000	SGDV-120A11A008000	-	-
<b>Sigma linear motors (refer to the Sigma linear motors chapter for details)</b>							
 SGLGW coreless standard-force magnetic ways	230 V	12.5 N (40 N peak)	-	SGDV-R70A05A	SGDV-R70A15A	-	-
		25 N (80 N peak)	-	SGDV-R90A05A	SGDV-R90A15A	-	-
		47 N (140 N peak)	-	SGDV-R90A05A	SGDV-R90A15A	-	-
		70 N (220 N peak)	-	SGDV-1R6A05A	SGDV-1R6A15A	-	-
		93 N (280 N peak)	-	SGDV-1R6A05A	SGDV-1R6A15A	-	-
		140 N (420 N peak)	-	SGDV-2R8A05A	SGDV-2R8A15A	-	-
		140 N (440 N peak)	-	SGDV-2R8A05A	SGDV-2R8A15A	-	-
		210 N (660 N peak)	-	SGDV-5R5A05A	SGDV-5R5A15A	-	-
 SGLGW coreless high-force magnetic ways	230 V	325 N (1300 N peak)	-	SGDV-120A05A008000	SGDV-120A15A008000	-	-
		57 N (230 N peak)	-	SGDV-R90A05A	SGDV-R90A15A	-	-
		114 N (460 N peak)	-	SGDV-1R6A05A	SGDV-1R6A15A	-	-
		171 N (690 N peak)	-	SGDV-2R8A05A	SGDV-2R8A15A	-	-
		85 N (360 N peak)	-	SGDV-1R6A05A	SGDV-1R6A15A	-	-
		170 N (720 N peak)	-	SGDV-2R8A05A	SGDV-2R8A15A	-	-
 SGLFW Linear motors	230 V	255 N (1080 N peak)	-	SGDV-5R5A05A	SGDV-5R5A15A	-	-
		25 N (86 N peak)	-	SGDV-1R6A05A	SGDV-1R6A15A	-	-
		40 N (125 N peak)	-	SGDV-1R6A05A	SGDV-1R6A15A	-	-
		80 N (220 N peak)	-	SGDV-1R6A05A	SGDV-1R6A15A	-	-
		160 N (440 N peak)	-	SGDV-5R5A05A	SGDV-5R5A15A	-	-
	400 V	280 N (600 N peak)	-	SGDV-5R5A05A	SGDV-5R5A15A	-	-
		560 N (1200 N peak)	-	SGDV-120A05A008000	SGDV-120A15A008000	-	-
		80 N (220 N peak)	-	-	-	SGDV-1R9D05A	SGDV-1R9D15A
		160 N (440 N peak)	-	-	-	SGDV-1R9D05A	SGDV-1R9D15A
		280 N (600 N peak)	-	-	-	SGDV-3R5D05A	SGDV-3R5D15A
 SGLTW Linear motors	400 V	560 N (1200 N peak)	-	-	-	SGDV-5R4D05A	SGDV-5R4D15A
		1120 N (2400 N peak)	-	-	-	SGDV-120D05A	SGDV-120D15A
		1500 N (3600 N peak)	-	-	-	SGDV-8R4D05A	SGDV-8R4D15A
		2250 N (5400 N peak)	-	-	-	SGDV-120D05A	SGDV-120D15A
		300 N (600 N peak)	-	-	-	SGDV-3R5D05A	SGDV-3R5D15A
		600 N (1200 N peak)	-	-	-	SGDV-8R4D05A	SGDV-8R4D15A
		450 N (900 N peak)	-	-	-	SGDV-3R5D05A	SGDV-3R5D15A
900 N (1800 N peak)	-	-	-	SGDV-8R4D05A	SGDV-8R4D15A		
670 N (2600 N peak)	-	-	-	SGDV-120D05A	SGDV-120D15A		
1000 N (4000 N peak)	-	-	-	SGDV-170D05A	SGDV-170D15A		
1300 N (5000 N peak)	-	-	-	SGDV-170D05A	SGDV-170D15A		



Servo drive

# SGDV-1R6A01A

Sigma-5 servo drive  
Continuous output

Voltage	Code	Current
230 V	R70	0.66 Arms
	R90	0.91 Arms
	1R6	1.6 Arms
	2R8	2.8 Arms
	5R5	5.5 Arms
	120	11.6 Arms
400 V	1R9	1.9 Arms
	3R5	3.5 Arms
	5R4	5.4 Arms
	8R4	8.4 Arms
	120	11.9 Arms
	170	16.5 Arms
	210	20.8 Arms
	260	25.4 Arms
	280	28.1 Arms
	370	37.2 Arms

Source voltage

A: 230 V  
D: 400 V

Code	Specifications
Blank	Standard
008000	Servo drive 1.5 kW single-phase 230 V

Design Revision Order: A,

B... Interface

Code	Specifications
01	Analog voltage/pulse train reference type (for rotary servomotors)
05	Analog voltage/pulse train reference type (for linear servomotors)
11	MECHATROLINK-II comms reference type (for rotary servomotors)
15	MECHATROLINK-II comms reference type (for linear servomotors)

## Single-phase, 230 V

Servo drive type	SGDV- @	R70A@@@A	R90A@@@A	1R6A@@@A	2R8A@@@A	5R5A@@@A	120A@@@A008000
Applicable servo motor	SGMAH-@	A3A@/A5A@	01A@	02A@	04A@	08A@	-
	SGMPH-@	-	01A@	02A@	04A@	08A@	15A@
	SGMJV-@	A5A@	01A@	02A@	04A@	08A@	-
	SGMAV-@	A5A@	01A@	C2A@/02A@	04A@	06A@/08A@	10A@
	SGMEV-@	-	01A@	02A@	04A@	08A@	15A@
Max. applicable motor capacity	W	50	100	200	400	750	1500
Continuous output current	Arms	0.66	0.91	1.6	2.8	5.5	11.6
Max. output current	Arms	2.1	2.9	6.5	9.3	16.9	28
Input power	Main circuit	Single-phase, 200 to 230 VAC + 10 to -15% (50/60 Hz)					
	Control circuit	Single-phase, 200 to 230 VAC + 10 to -15% (50/60 Hz)					
Control method	Single phase full-wave rectification / IGBT / PWM / sine-wave current drive method						
Feedback	Serial encoder (incremental/absolute)						
Conditions	Usage/storage temperature	0 to +55 °C / -20 to 85 °C					
	Usage/storage humidity	90%RH or less (non-condensing)					
	Altitude	1000m or less above sea level					
	Vibration/shock resistance	4.9 m/s <sup>2</sup> / 19.6 m/s <sup>2</sup>					
Configuration	Base mounted						
Approx. weight	Kg		0.9		1.0	1.5	2.8

## Three-phase, 400 V

Servo drive type	SGDV-@	1R9D@@@A	3R5D@@@A	5R4D@@@A	8R4D@@@A	120D@@@A	170D@@@A	210D@@@A	260D@@@A	280D@@@A	370D@@@A
Applicable servo motor	SGMAH-@	03D@	07D@	-	-	-	-	-	-	-	-
	SGMPH-@	02D@/04D@	08D@	15D@	-	-	-	-	-	-	-
	SGMGH-@	05D@	09D@	13D@	20D@	30D@	44D@	55D@	75D@	1AD@	1ED@
	SGMSH-@	-	10D@	15D@	20D@	30D@	40D@/50D@	-	-	-	-
	SGMUH-@	-	10D@	15D@	-	30D@	40D@	-	-	-	-
	SGMEV-@	02/03/04D@	07D@/08D@	15D@	-	-	-	-	-	-	-
	SGMGV-@	03D@/05D@	09D@	13D@	20D@	30D@	44D@	55D@	75D@	1AD@	1ED@
	SGMSV-@	-	10D@	15D@	20D@	25D@	40D@/50D@	-	-	-	-
Max. applicable motor capacity	kW	0.5	1.0	1.5	2.0	3.0	5.0	6.0	7.5	11	15
Continuous output current	Arms	1.9	3.5	5.4	8.4	11.9	16.5	20.8	25.4	28.1	37.2
Max. output current	Arms	5.5	8.5	14	20	28	42	55	65	70	85
Input power	Main circuit	Three-phase, 380 to 480 VAC + 10 to -15% (50/60Hz)									
	Control circuit	24 VDC +/-15%									
Control method	Three phase full-wave rectification / IGBT / PWM / sine-wave current drive method										
Feedback	Serial encoder (incremental/absolute)										
Conditions	Usage/storage temperature	0 to +55 °C / -20 to +85 °C									
	Usage/storage humidity	90%RH or less (non-condensing)									
	Altitude	1000 m or less above sea level									
	Vibration/shock resistance	4.9 m/s <sup>2</sup> / 19.6 m/s <sup>2</sup>									
Configuration	Base mounted										
Approx. weight	Kg		2.7		3.7		5.6		11.3		16.2

## Sigma-5 Analog/Pulse Reference Servo Drive

### General specifications

Speed/torque control mode	Speed control range		1:5000	
	Speed variance	Load variance	During 0 to 100% load $\pm 0.01\%$ max. (at rated speed)	
		Voltage variance	Rated voltage $\pm 10\%:0\%$ (at rated speed)	
		Temperature variance	$25 \pm 25$ °C: $\pm 0.1\%$ max. (at rated speed)	
	Frequency characteristics		1.6 kHz	
	Torque control accuracy (Repeatability)		$\pm 1\%$	
	Soft start time setting		0 to 10 s (acceleration, deceleration can each be set.)	
	Input signal	Speed reference input	Reference voltage	$\pm 6$ VDC (forward motor rotation if positive reference) at rated speed: Set at delivery Variable setting range: $\pm 2$ to $\pm 10$ VDC at rated speed/ max. input voltage: $\pm 12$ V
			Input impedance	Approx. 14 k $\Omega$
			Circuit time constant	Approx. 30 $\mu$ s
Torque reference input		Reference voltage	$\pm 3$ VDC (forward rotation if positive reference) at rated torque: Set at delivery Variable setting range $\pm 1$ to $\pm 10$ VDC at rated torque reference, max. input voltage: $\pm 12$ V	
		Input impedance	Approx. 14 K $\Omega$	
		Circuit time constant	Approx. 30 $\mu$ s	
Position control mode	Feedforward compensation		0 to 100% (setting resolution: 1%)	
	Position completed width setting		0 to 1073741824 command units (setting resolution: 1 command unit)	
	Input signal	Command pulse	Input pulse type	Sign + pulse train, 90° phase displacement 2-phase pulse (A-phase+ B-phase) or CCW/CW pulse train
		Input pulse form	Input pulse form	Non-insulated line driver (+5 V level), open collector.
			Input pulse frequency	0 to 4 Mpps (200 Kpps max. at open collector)
Control signal	Clears error pulse by external signal			
IO signal	Position signal output		A-phase, B-phase, C-phase: line driver output.	
	Sequence input signal		Servo ON, P control (or control mode switching, forward/reverse motor rotation by internal speed setting, zero clamp, command pulse inhibit), forward/reverse run prohibit, forward/reverse current limit (or internal speed switching), alarm reset.	
	Sequence output signal		Servo alarm, alarm codes (3-bit output): CN1 output terminal is fixed It is possible to output three types of signal form incl.: positioning complete, speed coincidence detection, servo-motor rotation detection, servo ready, current limit detection, speed limit detection, brake release, warning, NEAR.	
Integrated functions	USB Communications	Interface	Personal computer	
		Communications standard	Compliant with USB1.1 standard (12 Mbps)	
		Function	Status display, parameter settings, adjustment functions, utility functions, alarm traceback display, JOG run/ auto-tuning operations and graphing functions for speed/torque command signal, etc	
	Automatic load inertia detection		Automatic motor parameter setting. One parameter rigidity setting.	
	Dynamic brake (DB)		Operates during main power OFF, servo alarm, servo OFF or overtravel	
	Regenerative processing		Internal resistor included in models from 500 W to 5 kW. Regenerative resistor externally mounted (option).	
	Overtravel (OT) prevention function		DB stop, deceleration stop or coast to stop during P-OT, N-OT operation	
	Encoder divider function		Optional division pulses possible	
	Electronic gearing		$0,01 < \text{Numerator/Denominator} < 100$	
	Internal speed setting function		3 speeds may be set internally	
	Protective functions		Overcurrent, overvoltage, low voltage, overload, regenerative error	
	Analog monitor functions for supervision		Integrates analog monitor connector for supervision of the speed and torque reference signals, etc. Number of channels: 2 (Output voltage: $\pm 10$ V DC)	
	Panel operator	Display functions	CHARGE, 7-segments LEDx5	
		Panel operator keys	Used to set parameters (4 keys)	
	Safety functions		Hard wire base block signal and status monitor (fixed output) of safety circuit	
	Others		Reverse connection, zero search, automatic motor discrimination function, and DC reactor connection terminal for high frequency power suppression function.	

I/O specifications

I/O signals (CN1) - input signals

Pin No.	Signal name	Function				
40	Common	/S-ON Servo ON: Turns ON the servo motor.				
41	/P-CON	Function selected by parameter.				
		Proportional control reference Switches the speed control loop from PI (proportional/integral) to P (proportional) control when ON.				
		Direction reference With the internal set speed selected: switch the rotation direction.				
		Control mode switching <table border="0" style="margin-left: 20px;"> <tr> <td>Position ↔ speed</td> <td rowspan="3">} Enables control mode switching</td> </tr> <tr> <td>Position ↔ torque</td> </tr> <tr> <td>Torque ↔ speed</td> </tr> </table>	Position ↔ speed	} Enables control mode switching	Position ↔ torque	Torque ↔ speed
		Position ↔ speed	} Enables control mode switching			
		Position ↔ torque				
Torque ↔ speed						
Zero-clamp reference Speed control with zero-clamp function: reference speed is zero when ON.						
Reference pulse block Position control with reference pulse stop: stops reference pulse input when ON.						
42	P-OT	Forward run prohibited				
43		N-OT Reverse run prohibited				
45 46	/P-CL /N-CL	Function selected by parameter.				
		Forward external torque limit ON Current limit function enabled when ON.				
		Reverse external torque limit ON				
44	/ALM-RST	Internal speed switching With the internal set speed selected: switches the internal speed settings.				
47	+24VIN	Alarm reset: releases the servo alarm state.				
4 (2)	SEN	Control power supply input for sequence signals: users must provide the +24 V power supply. Allowable voltage fluctuation range: 11 to 25 V				
21	BAT (+)	Initial data request signal when using an absolute encoder.				
22		BAT (-) Connecting pin for the absolute encoder backup battery. Do not connect when the encoder cable for the battery case is				
5 (6)	Speed	V-REF Speed reference input: $\pm 2$ to $\pm 10$ V/rated motor speed (Input gain can be modified using a parameter).				
9 (10)	Torque	T-REF Torque reference input: $\pm 1$ to $\pm 10$ V/rated motor torque (Input gain can be modified using a parameter).				
7 8 11 12	Position	PULS /PULS SIGN /SIGN Reference pulse input for line driver only Input mode is set from the following pulses: Sign + pulse string CCW/CW pulse Two-phase pulse (90° phase differential)				
15 14		CLR /CLR Positional error pulse clear input: clears the positional error pulse during position control.				

**Note:** 1. Pin numbers in parentheses () indicate signal grounds.

2. The functions allocated to /S-ON, /P-CON, P-OT, N-OT, /ALM-RST, /P-CL, and /N-CL input signals can be changed by using the parameters.

3. The voltage input range for speed and torque references is a maximum of  $\pm 12$  V.

### I/O signals (CN1) - output signals

Pin No.	Signal Name	Function	
31	Common	ALM+	
32		ALM-	
27		/TGON+	
28		/TGON-	
29		/S-RDY+	
30		/S-RDY-	
33		PAO	Two-phase pulse encoder output pulse signal
34		/PAO	
35		PBO	Phase-B signal
36		/PBO	
19	PCO	Phase-C signal	
20	/PCO		
37 (1)	ALO1	Alarm code output: Outputs 3-bit alarm codes.	
38 (1)			ALO2
39 (1)			ALO3
Shell	FG	Connected to frame ground if the shield wire of the I/O signal cable is connected to the connector shell.	
25	Speed	/V-CMP+	
26		/V-CMP-	
25	Position	/COIN+	
26		/COIN-	
-	Reserved	/CLT	
		/VLT	
		/BK	
		/WARN	
		/NEAR	
3		-	Terminals not used. Do not connect.
13			
16			
17			
18			
23			
24			
48			
49			
50			

**Note:** 1. Pin numbers in parentheses () indicate signal grounds.

2. The functions allocated to /TGON, /S-RDY, and /V-CMP (/COIN) output signals can be changed by using the parameters. /CLT, /VLT, /BK, /WARN and /NEAR signals can also be changed.

### I/O signals (CN8) - safety signals

Pin No.	Signal Name	Function
4	Common	/HWBB1+
3		/HWBB1-
6		/HWBB2+
5		/HWBB2-
8	EDMI+	Monitored circuit status output 1: ON when the hard wire baseblock function is normally
7		
1	Reserved	-
2		-

### Terminal specifications

Symbol	Name	Function
L1, L2 or L1, L2, L3	Main circuit AC input terminal	AC power input terminals for the main circuit
U, V, W	Servo motor connection terminal	Terminals for outputs to the servo motor.
L1C, L2C	Control power input terminal	AC power input terminals for the control circuit.
24V, 0V		24V DC power input terminals for the control circuit.
⊕	Frame ground	Ground terminal. Ground to a maximum of 100 Ω. (class 3).
B1/ ⊕, B2, B3	Main circuit DC output terminal	Up to 400 W: If the regenerative capacity is insufficient, connect an external regenerative resistor (option) between B1/ ⊕ and B2. From 500 W to 5 kW: Normally short B2 and B3. If the internal regenerative resistor is insufficient, remove the wire between B2 and B3 and connect an external regenerative resistor between B1/ ⊕ and B3.
⊖1, ⊖2	DC reactor connection terminal for suppressing power supply harmonic waves	Normally, short ⊖1 and ⊖2. If a countermeasure against power supply harmonic waves is needed, connect a DC reactor between ⊖1 and ⊖2.

### Encoder connector (CN2)

Pin No.	Signal Name	Function
1	E5V	Encoder power supply + 5 V
2	E0V	Encoder power supply ground
3	BAT+	Battery + (used only with absolute encoder)
4	BAT-	Battery - (used only with absolute encoder)
5	S+	Encoder serial signal input
6	S-	Encoder serial signal input



Sigma-5 MECHATROLINK-II Servo Drive

General specifications

Position/speed/torque control mode	Speed control range		1:5000
	Speed variance	Load variance	During 0 to 100% load $\pm 0.01\%$ max. (at rated speed)
		Voltage variance	Rated voltage $+10\%:0\%$ (at rated speed)
		Temperature variance	$25 \pm 25$ °C: $\pm 0.1\%$ max. (at rated speed)
	Frequency characteristics		1.6 kHz
Torque control accuracy (Repeatability)		$\pm 1\%$	
Soft start time setting		0 to 10 s (acceleration, deceleration can each be set.)	
Command input	MECHATROLINK Communication		MECHATROLINK-II commands (for sequence, motion, data setting/reference, monitor, adjustment and other commands)
	Position signal output		A-phase, B.phase, C-phase: line driver output.
I/O signal	Sequence input signal		Homing deceleration limit switch, forward/reverse run prohibited, external latch signals, forward/reverse current limit.
	Sequence output signal		It is possible to output three types of signal form incl.: positioning complete, speed coincidence detection, servo-motor rotation detection, servo ready, current limit detection, speed limit detection, brake release, warning, NEAR.
Communications	USB Communications	Interface	Personal computer
		Communications standard	Compliant with USB1.1 standard (12 Mbps)
		Function	Status display, parameter setting, adjusting functions, utility functions, alarm traceback display, JOG run/autotuning operations and graphing functions for speed/torque command signal, etc
	Mechatrolink Communications	Communications protocol	MECHATROLINK-II
		Station Address	41H to 5FH (max. number of slaves: 30)
		Transmission Speed	10 Mbps
		Transmission Cycle	250 $\mu$ s, 0.5 to 4.0 ms (multiple of 0.5 ms)
Data length	17-bytes and 32-bytes		
Automatic load inertia detection		Automatic motor parameter setting. One parameter rigidity setting.	
Dynamic brake (DB)		Operates during main power OFF, servo alarm, servo OFF or overtravel	
Regenerative processing		Internal resistor included in models from 500 W to 5 kW. Regenerative resistor externally mounted (option).	
Overtravel (OT) prevention function		DB stop, deceleration stop or coast to stop during P-OT, N-OT operation	
Encoder divider function		Optional division pulses possible	
Electronic gearing		$0,01 < \text{Numerator/Denominator} < 100$	
Internal speed setting function		3 speeds may be set internally	
Protective functions		Overcurrent, overvoltage, low voltage, overload, regeneration error	
Analog monitor functions for supervision		Integrates analog monitor connectors for supervision of the speed and torque reference signals, etc. Number of channels: 2 (Output volatge: $\pm 10$ V DC).	
Panel operator	Display functions	CHARGE, 7-segments LEDX1	
	Switches	Rotary switch: MECHATROLINK-II station address setting (16 channels) DIP switch: MECHATROLINK-II communications setting (4 channels)	
Safety functions		Hard wire base block signal and status monitor (fixed output) of safety circuit	
Others		Reverse connection, zero search, automatic motor discrimination function, and DC reactor connection terminal for high frequency power suppression function.	

I/O specifications

I/O signals (CN1) - input signals

Pin No.	Signal name	Function
9	Common	/DEC Homing deceleration limit switch
7	Common	P-OT Forward run prohibited
8		N-OT Reverse run prohibited
10		/EXT 1 External latch signal 1
11	/EXT 2 External latch signal 2	
12	/EXT 3 External latch signal 3	
6	+24VIN	Control power supply input for sequence signals: users must provide the +24 V power supply. Allowable voltage fluctuation range: 11 to 25 V.
14	BAT (+)	Connecting pin for the absolute encoder backup battery.
15	BAT (-)	Do not connect when a battery is connected to the host
13	/SIO	Control purpose input signal: Monitored in the I/O monitor field of MECHATROLINK-II.

- Note:**
- The functions allocated to /DEC, P-OT, N-OT, /EXT1, /EXT2 and /EXT3 input signals can be changed by using the parameters.
  - If the Forward/ Reverse run prohibited function is used, the software can be used to stop the Servo drive. If the application does not satisfy the requirements, add an external circuit for safety reasons as required.

### I/O signals (CN1) - output signals

Pin No.	Signal Name	Function
3 4	Common	ALM+ ALM- Servo alarm: Turns OFF when an error is detected.
1 2	/BK+ (/SO1+) /BK- (/SO1-)	Brake interlock signal Controls the brake. The brake is released when the signal turns ON. Allocation can be changed to general-purpose output signals (/SO1+, /SO1-).
23 24 25 26	/SO2+ /SO2- /SO3+ /SO3-	General-purpose output signal. Note: Set the parameter to allocate a function.
16	FG	Signal ground: Connected to frame ground if the shield wire of the I/O signal cable is connected to the connector
17 18	PAO /PAO	Phase-A signal Dividing ratio can be set by parameter (proper line receiver is SN75175 manufactured by Texas instruments or the equivalent corresponding to MC3486)
19 20	PBO /PBO	Phase-B signal
21 22	PCO /PCO	Phase-C signal
5	Reserved	- Terminal not used. Do not connect.

### I/O signals (CN8) - safety signals

Pin No.	Signal Name	Function
4 3	Common	/HWBB1+ /HWBB1- Hard wire baseblock input 1
6 5		/HWBB2+ /HWBB2- Hard wire baseblock input 2
8 7		EDMI+ EDMI- Monitored circuit status output 1: ON when the hard wire baseblock function is normally
1 2	Reserved	- Terminals not used. Do not connect.

### Terminal specifications

Symbol	Name	Function
L1, L2 or L1, L2, L3	Main circuit AC input terminal	AC power input terminals for the main circuit
U, V, W	Servo motor connection terminal	Terminals for outputs to the servo motor.
L1C, L2C	Control power input terminal	AC power input terminals for the control circuit.
24V, 0		24V DC power input terminals for the control circuit.
⊖	Frame ground	Ground terminal. Ground to a maximum of 100 Ω. (class 3).
B1/⊕, B2, B3 or B1, B2, B3	Main circuit DC output terminal	Up to 400 W: If the regenerative capacity is insufficient, connect an external regenerative resistor (option) between B1/⊕ and B2. From 500 W to 5 kW: Normally short B2 and B3. If the internal regenerative resistor is insufficient, remove the wire between B2 and B3 and connect an external regenerative resistor between B1/⊕ and
⊖1, ⊖2	DC reactor connection terminal for suppressing power supply harmonic waves	Normally, short ⊖1 and ⊖2. If a countermeasure against power supply harmonic waves is needed, connect a DC reactor between ⊖ and 2.

### Encoder connector (CN2)

Pin No.	Signal Name	Function
1	E5V	Encoder power supply + 5 V
2	E0V	Encoder power supply ground
3	BAT+	Battery + (used only with absolute encoder)
4	BAT-	Battery - (used only with absolute encoder)
5	S+	Encoder serial signal input
6	S-	Encoder serial signal input

Operation

Sigma-5 Analog/Pulse Reference Servo Drive

Panel operator

With front cover open

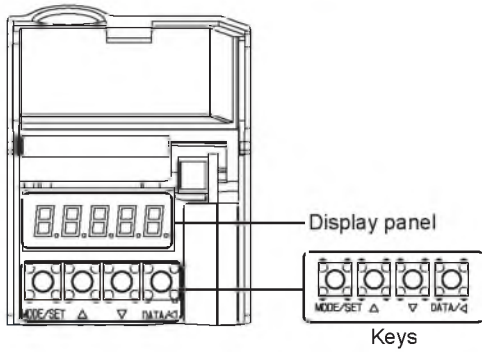

Changing modes

To change modes, press the MODE/SET key.

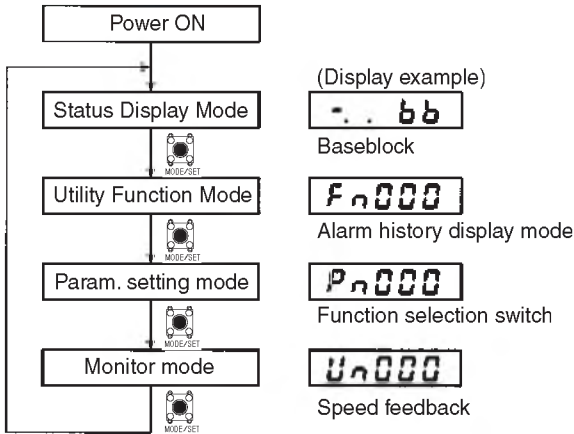

Status display mode

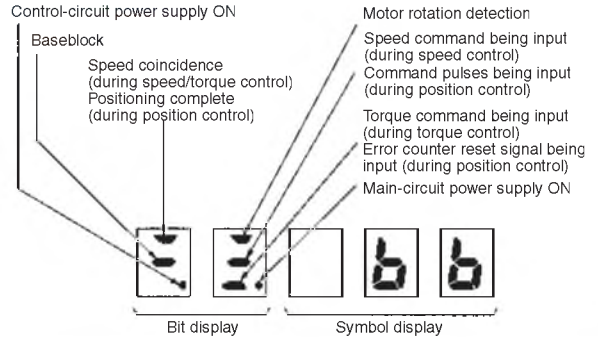

Symbol	Status
<i>bb</i>	Baseblock (servo OFF)
<i>run</i>	Operating (servo on)
<i>For</i>	Forward rotation prohibited (forward overtravel)
<i>ror</i>	Reverse rotation prohibited (reverse overtravel)
<i>H.bb</i>	Hard Wire Base Block. Servo drive is baseblocked by the safety function
<i>Est</i>	Mode test without motor
<i>De</i>	Alarm. Blinks the alarm number

Keys

Key name	SGDV-□□□□0□A	Function
MODE/SET Key		Selects the display mode (status display mode, utility function mode, parameter setting mode and monitor mode). Used as a data setting key while in setting mode. Turns the servo ON or OFF while jog operations are being performed.
UP Key		Increments parameter settings. Used as a forward rotation start key during jog operation.
DOWN Key		Decrements parameter settings. Used as a reverse rotation start key during jog operation.
DATA/SHIFT Key		To set and display the set value. Selects the digit whose setting is to be changed. When selected, the digit flashes.
UP Key + DOWN Key		Pressing the UP Key and the Down Key simultaneously, resets an alarm.

Sigma-5 MECHATROLINK-II Servo Drive

Display panel

With front cover open

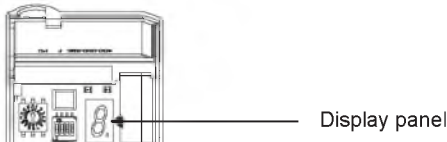

Status display mode

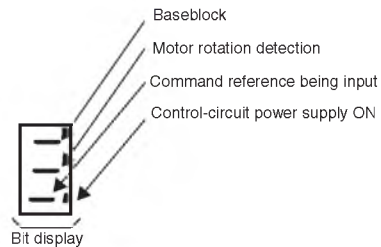

Symbol	Status
<i>A. E 6 0</i>	A. E60. Alarm number 60
<i>H. b b</i>	Hard Wire Base Block. Servo drive is baseblocked by the safety function
<i>E 5 E</i>	Mode test without motor

**Dimensions**

**Sigma-5 Servo Drive**

SGDV-R70A□□A to -1R6A□□A (230 V, 50 to 200 W)

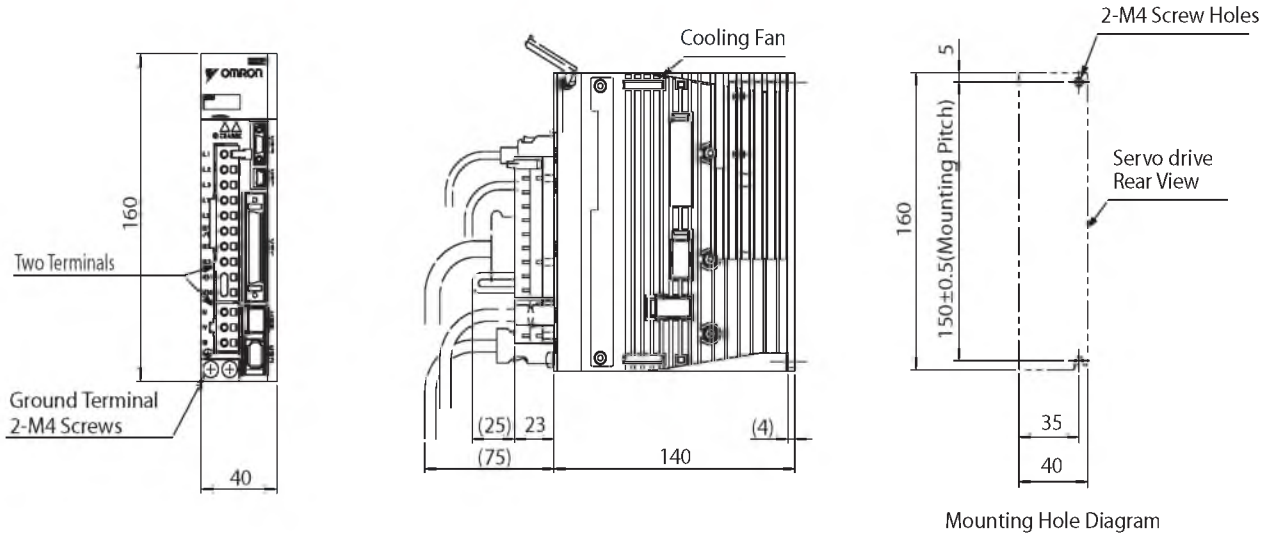

SGDV-2R8A□□A (230 V, 400 W)

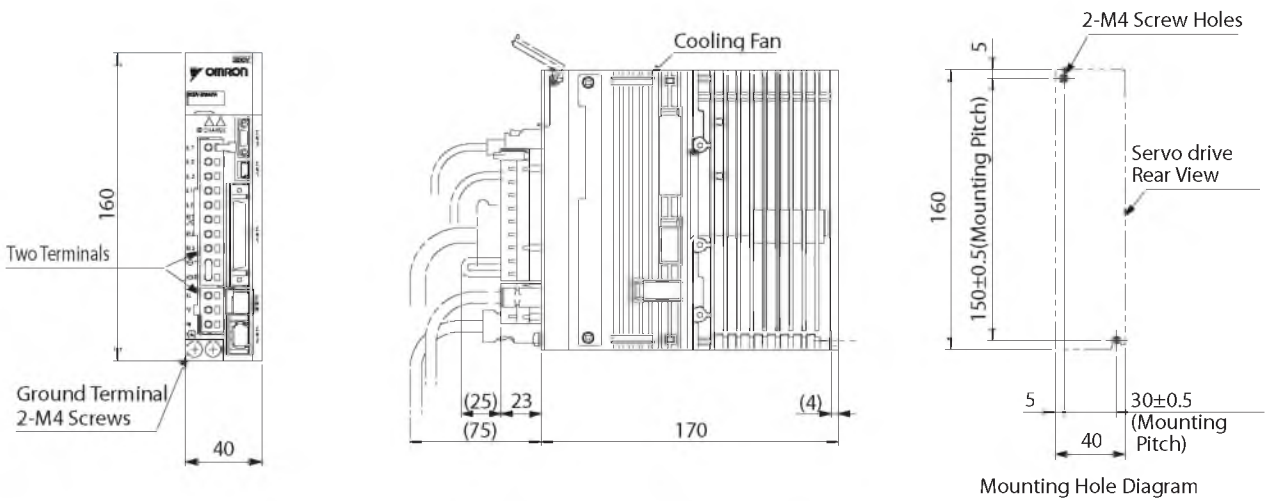

SGDV-5R5A□□A (230 V, 750 W)

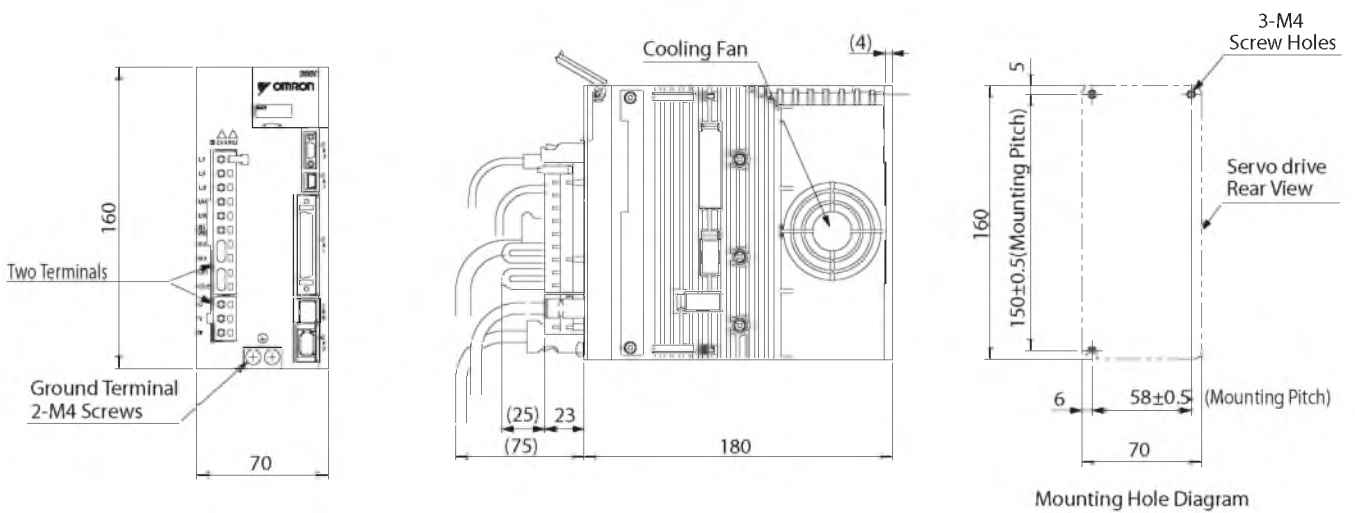

SGDV-120A□□A008000 (230 V, 1.5 kW)

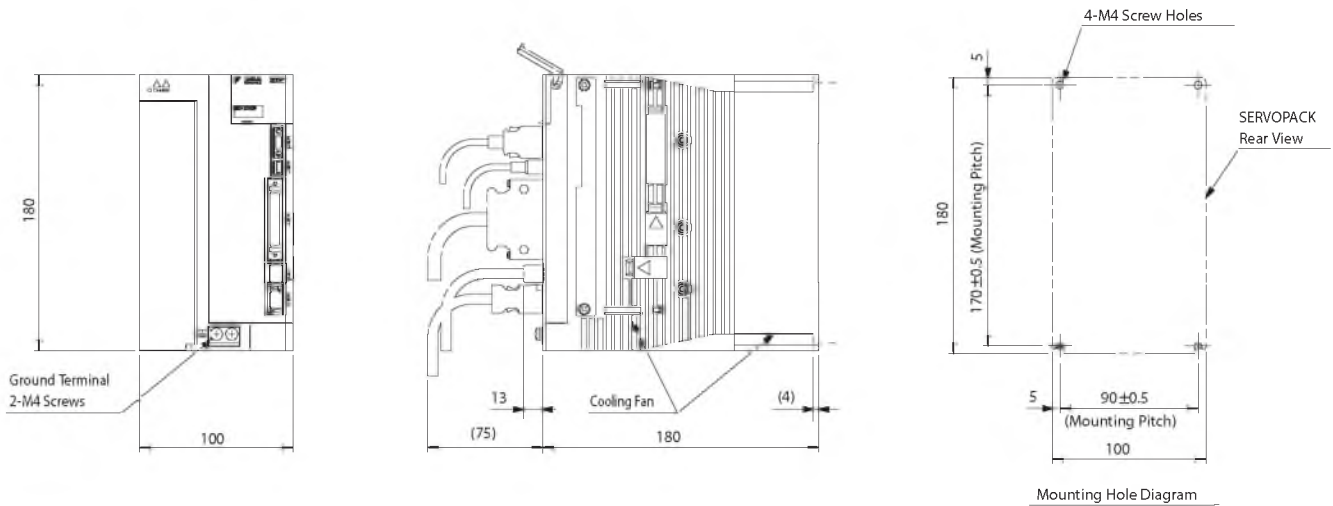

SGDV-1R9D□□A to -5R4D□□A (400 V, 0.5 to 1.5 kW)

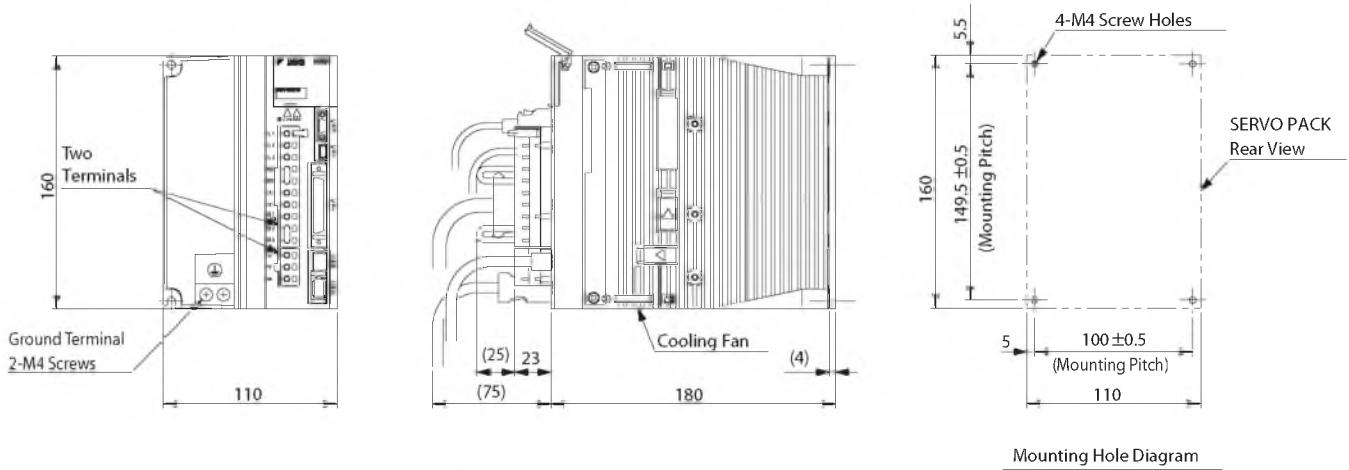

SGDV-8R4D□□A to -120D□□A (400 V, 2 to 3 kW)

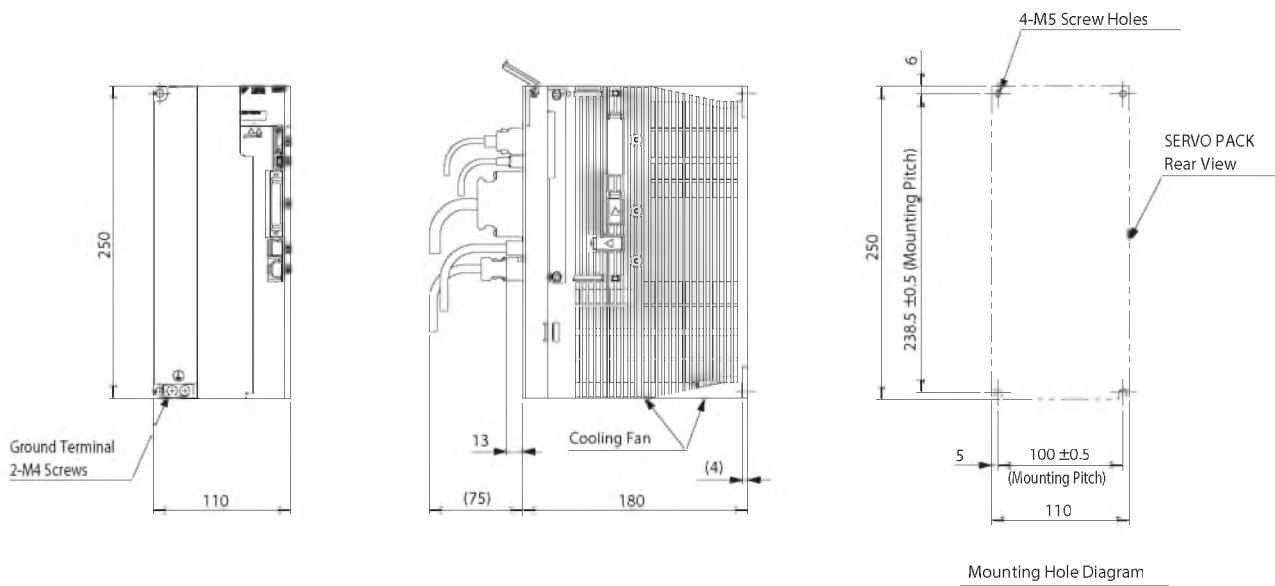



SGDV-170D□□A (400 V, 5 kW)

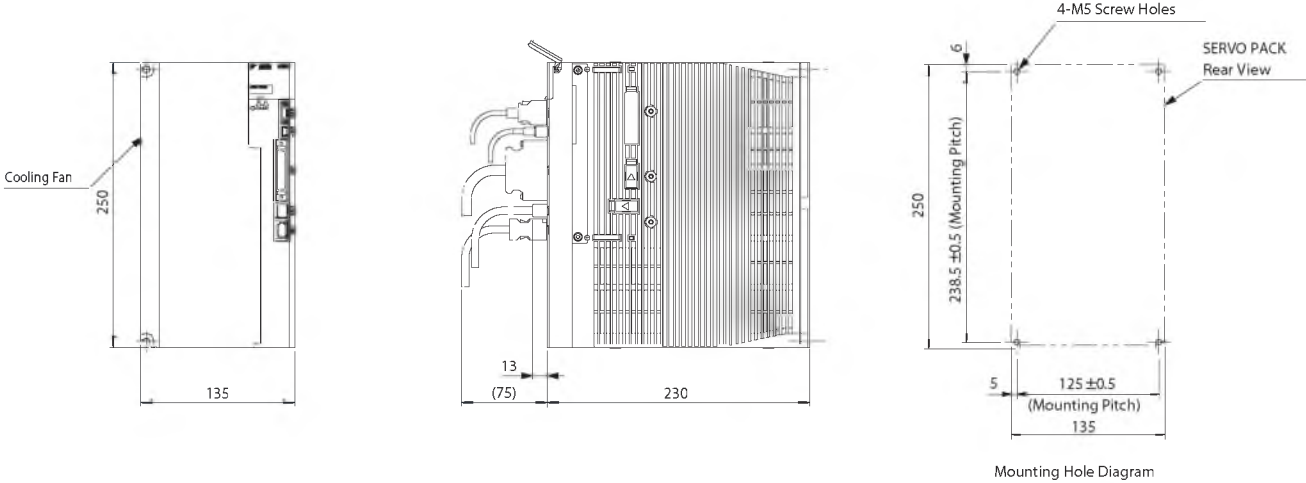

SGDV-210D□1A to 260D□1A (400 V, 6 to 7.5 kW)

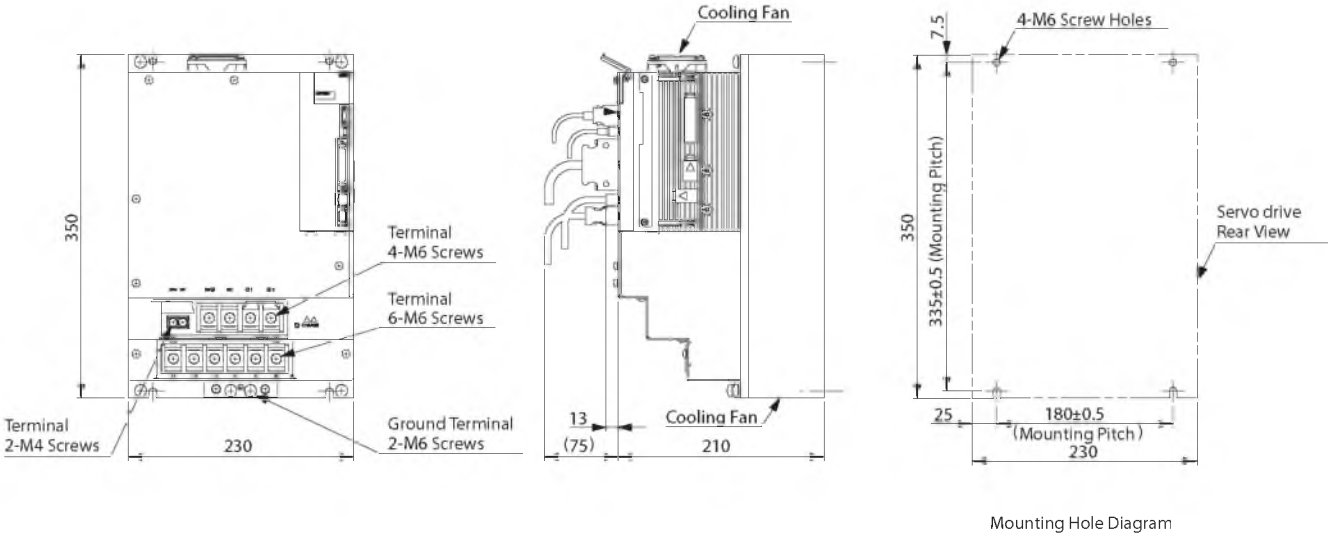

SGDV-280D□1A to 370D□1A (400 V, 11 to 15 kW)

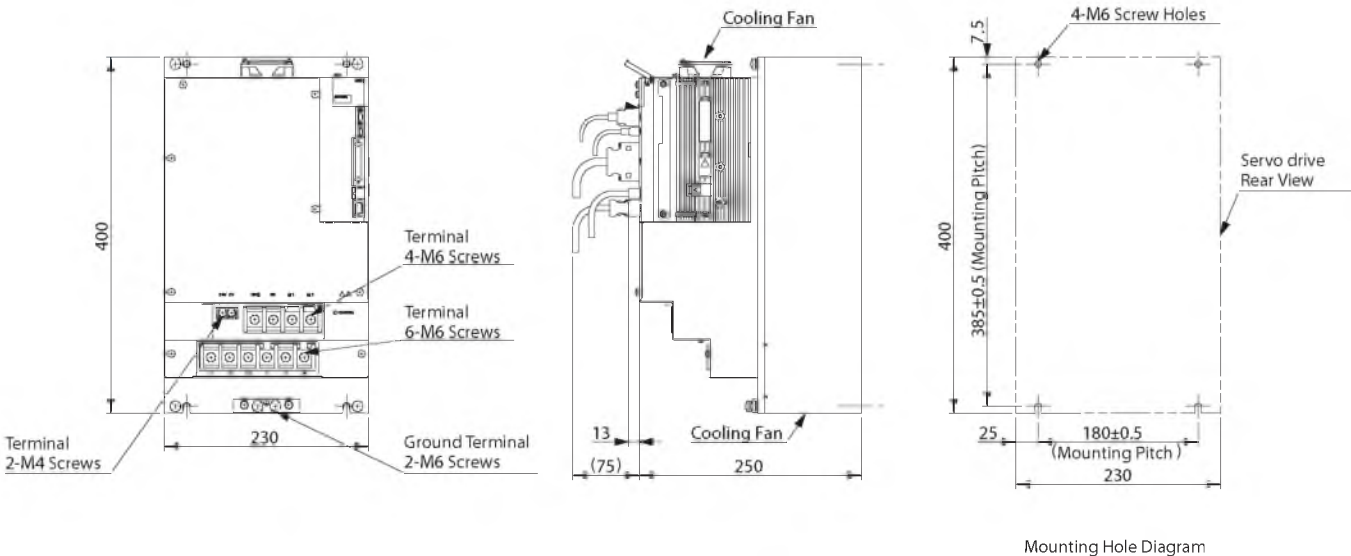

Filters

R88A-FI5-1005-RE

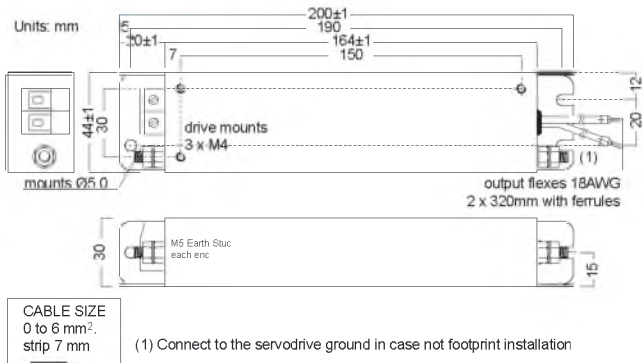

R88A-FI5-3004-RE

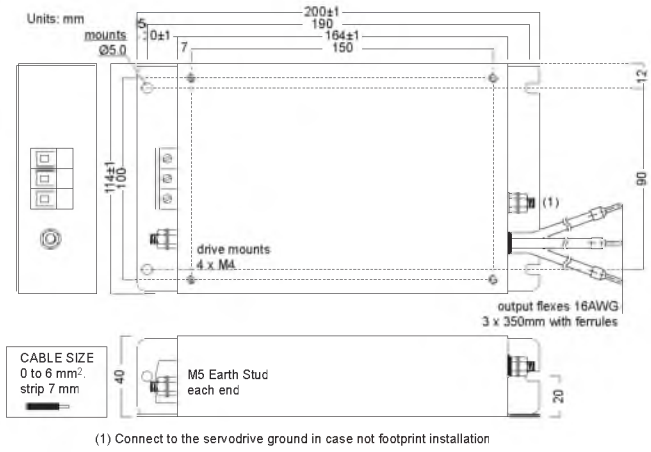

R88A-FI5-1009-RE

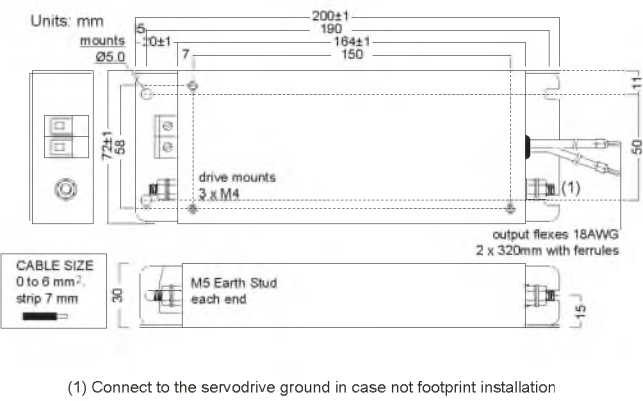

R88A-FI5-3008-RE

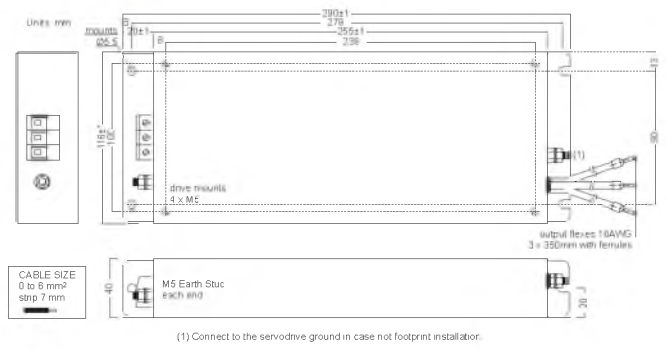

R88A-FI5-1016-RE

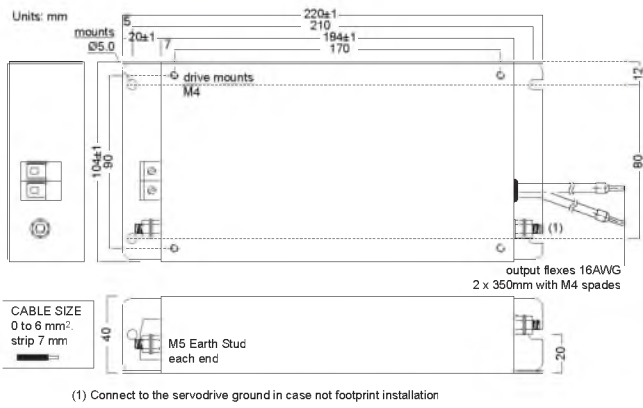

R88A-FI5-3012-RE

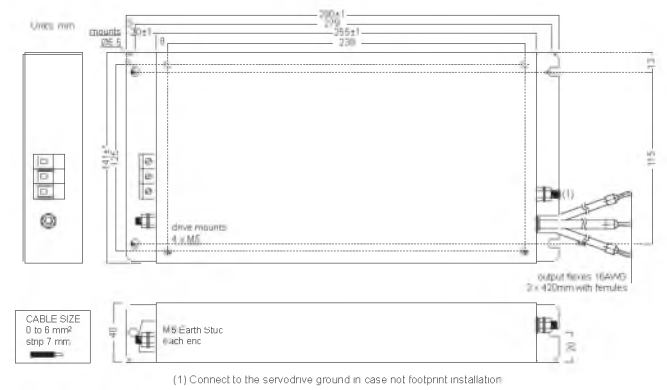

Single-phase, 230 VAC

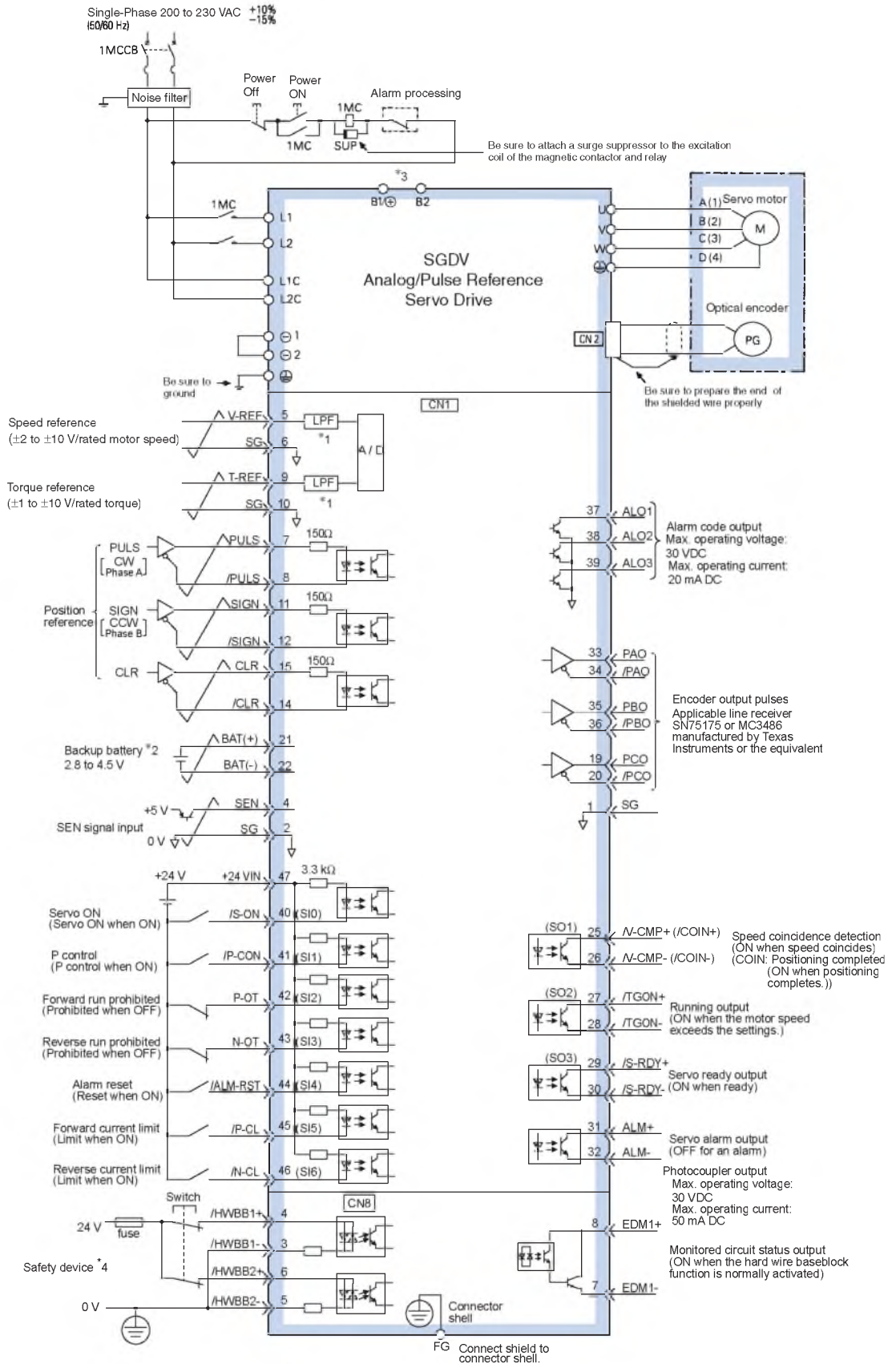

\*1 The time constant for the primary filter is 30  $\mu$ s.

\*2 Connect when using an absolute encoder. When the encoder cable for the battery case is connected, do not connect a backup battery.

\*3 Regenerative resistor can be connected between B1 and B2. For 750 W servo drives types normally short B2 and B3.

\*4 For servo ON, connect to safety device and set wiring to enable safety function. When not using the safety function, use the servo drive with the plug (JZSP-CVH05-E, provided as an accessory) inserted into the CN8.

Three-phase, 400 VAC

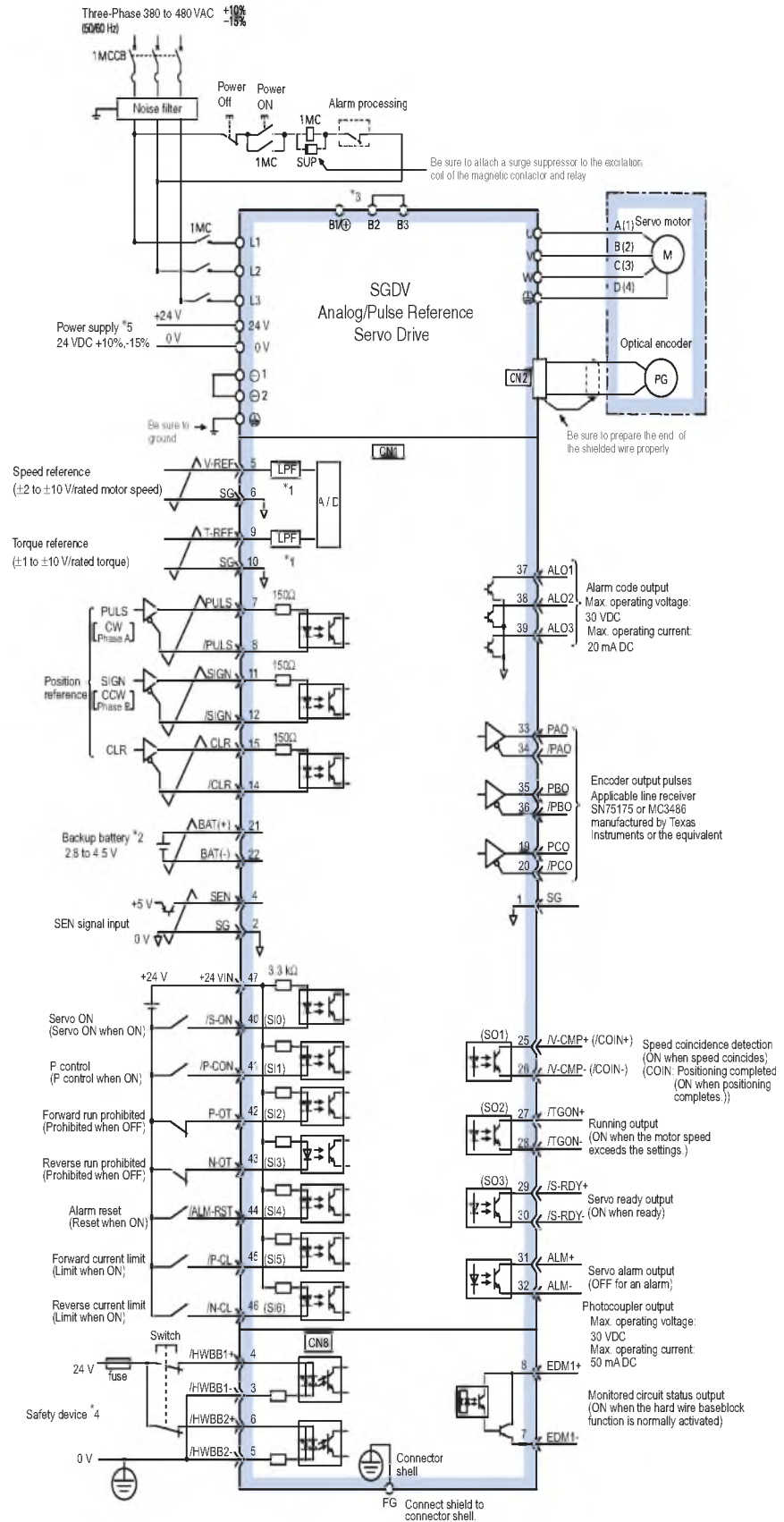

\*1 The time constant for the primary filter is 30  $\mu$ s.

\*2 Connect when using an absolute encoder. When the encoder cable for the battery case is connected, do not connect a backup battery.

\*3 Normally short B2 and B3. If the internal regenerative resistor is insufficient, remove the wire between B2 and B3 and connect an external regenerative resistor between B1 and B2.

\*4 For servo ON, connect to safety device and set wiring to enable safety function. When not using the safety function, use the servo drive with the plug (JZSP-CVH05-E, provided as an accessory) inserted into the CN8.

\*5 It is the user's responsibility to obtain 24 VDC power supply.



Single-phase, 230 VAC

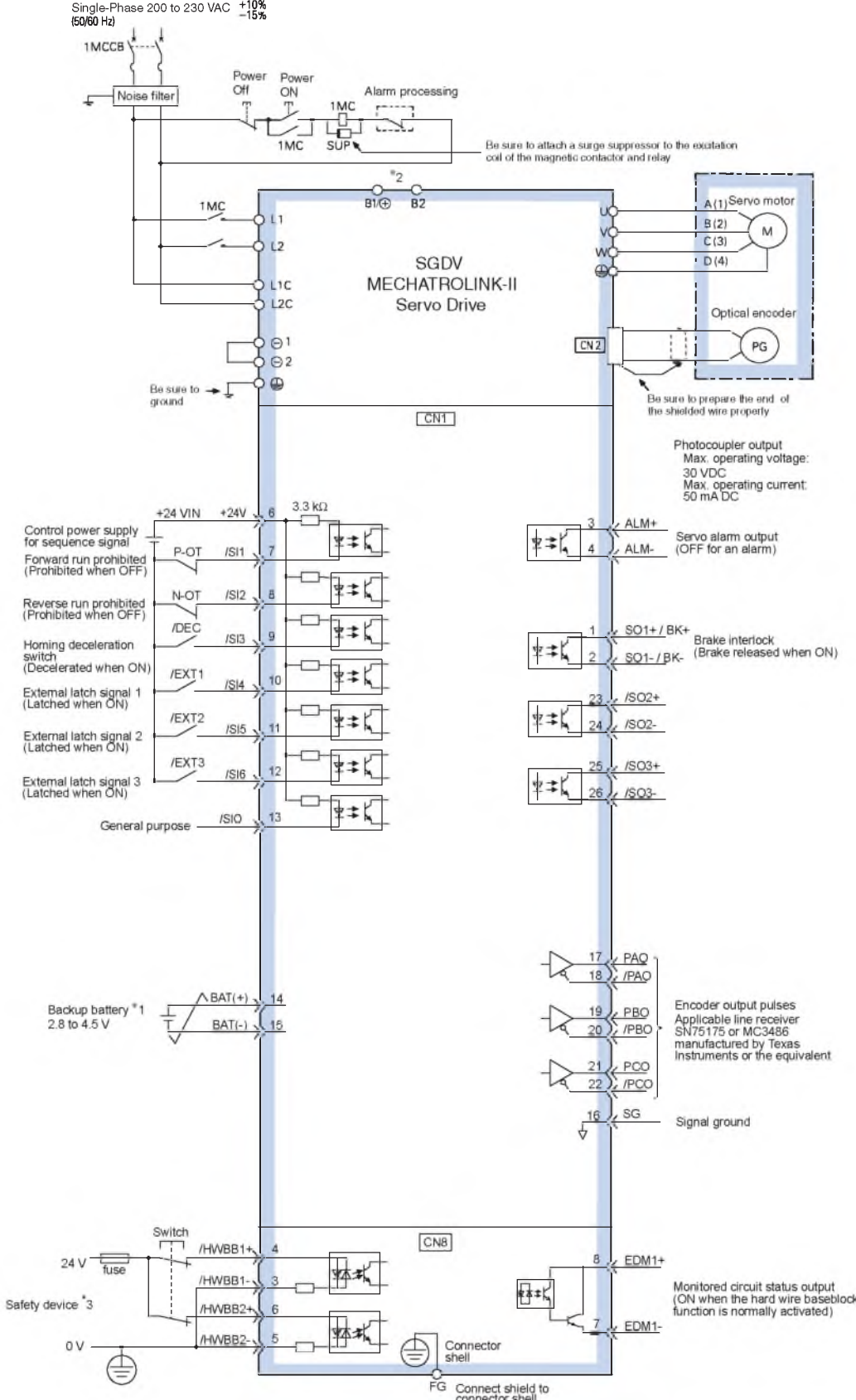

\*1 Connect when using an absolute encoder. When the encoder cable for the battery case is connected, do not connect a backup battery.  
 \*2 Regenerative resistor can be connected between B1 and B2. For 750 W servo drives types normally short B2 and B3.  
 \*3 For servo ON, connect to safety device and set wiring to enable safety function. When not using the safety function, use the servo drive with the plug (JZSP-CVH05-E, provided as an accessory) inserted into the CN8.



Three-phase, 400 VAC

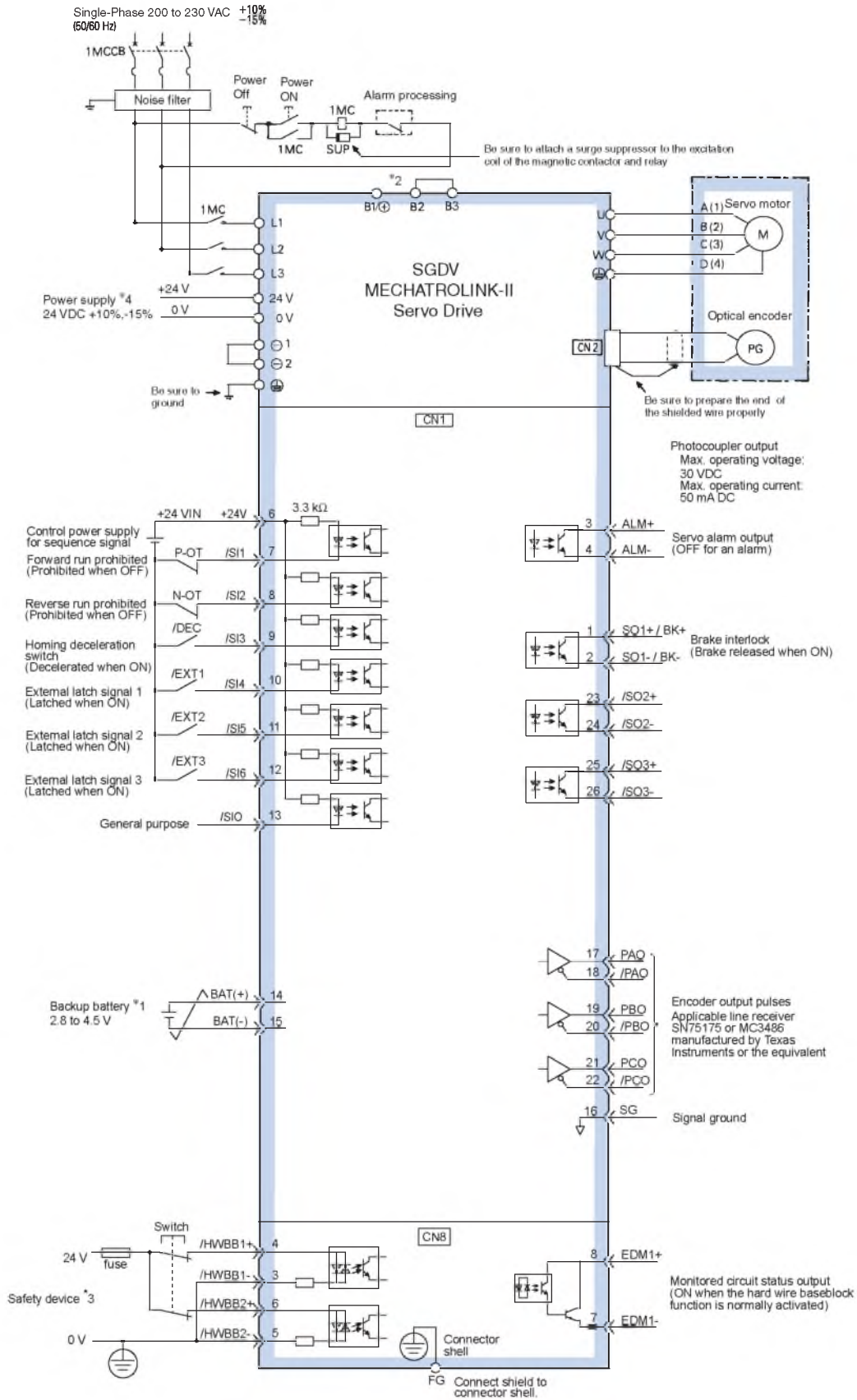

- \*1 Connect when using an absolute encoder. When the encoder cable for the battery case is connected, do not connect a backup battery.
- \*2 Normally short B2 and B3. If the internal regenerative resistor is insufficient, remove the wire between B2 and B3 and connect an external regenerative resistor between B1 and B2.
- \*3 For servo ON, connect to safety device and set wiring to enable safety function. When not using the safety function, use the servo drive with the plug (JZSP-CVH05-E, provided as an accessory) inserted into the CN8.
- \*4 It is the user's responsibility to obtain 24 VDC power supply.

Ordering information

Sigma-5 Analog/Pulse Reference Configuration

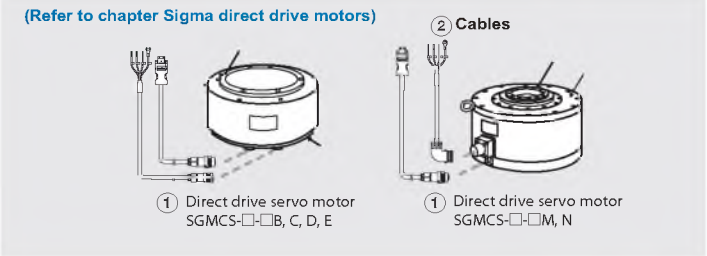
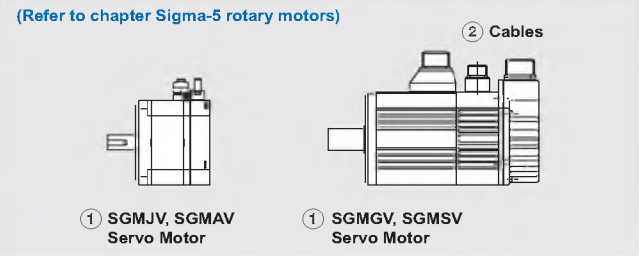
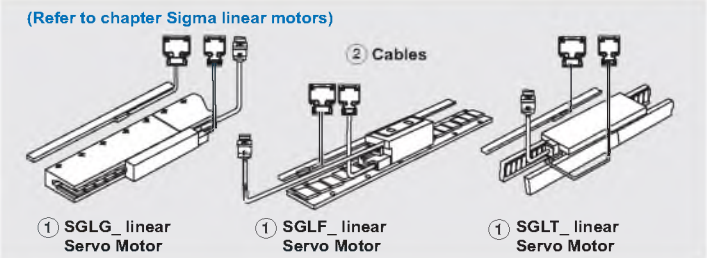
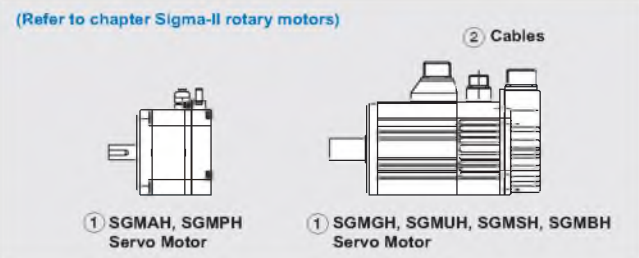
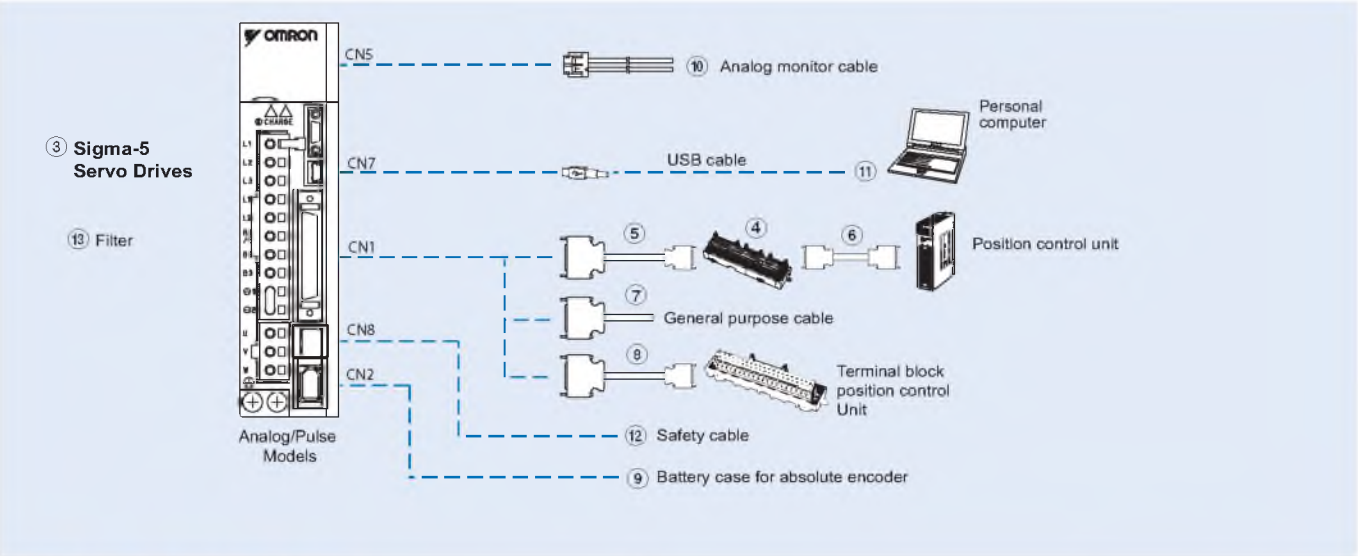

Note: The symbols ①②③④⑤... show the recommended sequence to select the components in a Sigma-5 servo system

Servo motors, power & encoder cables

Note: ①② Refer to the servo motors chapter for detailed motor specifications and selection

Servo drives

Symbol	Specifications	Model	Compatible rotary servo motors ①	Compatible direct drive motors ①	Compatible linear motors ①		
③	1 phase 230 VAC	50 W	SGDV-R70A01A	SGMAH-A5D□, SGMJV-A5A□, SGMAV-A5A□	-	-	
			SGDV-R70A05A	-	-	SGLGW-30A050□	
		100 W	SGDV-R90A01A	SGMAH-01A□, SGMPH-01A□, SGMJV-01A□, SGMAV-01A□, SGMEV-01A□	*	-	-
			SGDV-R90A05A	-	-	-	SGLGW-30A080□, SGLGW-40A140□
		200 W	SGDV-1R6A01A	SGMAH-02A□, SGMPH-02A□, SGMJV-02A□, SGMAV-02A□, SGMEV-02A□	SGMCS-07B□	-	-
			SGDV-1R6A05A	-	-	-	SGLGW-60A140□, SGLGW-40A253□, SGLFW-20A□, SGLFW-35A120□
		400 W	SGDV-2R8A01A	SGMAH-04A□, SGMPH-04A□, SGMJV-04A□, SGMAV-04A□, SGMEV-04A□	SGMCS-02B□, SGMCS-05B□, SGMCS-04C□, SGMCS-10C□, SGMCS-14C□, SGMCS-08D□, SGMCS-17D□, SGMCS-25D□	-	-
			SGDV-2R8A05A	-	-	-	SGLGW-40A365□, SGLGW-60A253A□
		750 W	SGDV-5R5A01A	SGMAH-08A□, SGMPH-08A□, SGMJV-08A□, SGMAV-08A□, SGMEV-08A□	SGMCS-16E□, SGMCS-35E□	-	-
			SGDV-5R5A05A	-	-	-	SGLGW-60A365A□, SGLFW-35A230□, SGLFW-50A200□
	1.5 kW	SGDV-120A01A008000	SGMPH-15A□, SGMAV-10A□, SGMEV-15A□	SGMCS-45M□, SGMCS-80M□, SGMCS-80N□	-	-	
		SGDV-120A05A008000	-	-	-	SGLGW-90A200A□, SGLFW-50A380□, SGLFW-1ZA200□	
	3 phase 400 VAC	0.5 kW	SGDV-1R9D01A	SGMAH-03D□, SGMPH-04D□, SGMGH-05D□, SGMEV-04D□, SGMGV-05D□	*	-	
			SGDV-1R9D05A	-	-	-	SGLFW-35D□
		1.0 kW	SGDV-3R5D01A	SGMAH-07D□, SGMPH-08D□, SGMGH-09D□, SGMSh-10D□, SGMUH-10D□, SGMEV-08D□, SGMGV-09D□, SGMSV-10D□,	*	-	-
			SGDV-3R5D05A	-	-	-	SGLFW-50D200□, SGLTW-35D170□, SGLTW-50D170□
		1.5 kW	SGDV-5R4D01A	SGMPH-15D□, SGMGH-13D□, SGMSh-15D□, SGMUH-15D□, SGMEV-15D□, SGMGV-13D□, SGMSV-15D□	*	-	-
			SGDV-5R4D05A	-	-	-	SGLFW-50D380□, SGLFW-1ZD200□
		2 kW	SGDV-8R4D01A	SGMGH-20D□, SGMSh-20D□, SGMGV-20D□, SGMSV-20D□	-	-	-
			SGDV-8R4D05A	-	-	-	SGLFW-1ED380□, SGLTW-35D320□, SGLTW-50D320□
3 kW		SGDV-120D01A	SGMGH-30D□, SGMSh-30D□, SGMUH-30D□, SGMGV-30D□, SGMGV-30D□	-	-	-	
		SGDV-120D05A	-	-	-	SGLFW-1ZD380□, SGLFW-1ED560□, SGLTW-40D400□	
5 kW		SGDV-170D01A	SGMGH-44D□, SGMSh-50D□, SGMUH-40D□, SGMGV-44D□, SGMSV-50D□	-	-	-	
		SGDV-170D05A	-	-	-	SGLTW-40D60□, SGLTW-80D400□	
6 kW		SGDV-210D01A	SGMGH-55D□, SGMGV-55D□	-	-	-	
7.5 kW		SGDV-260D01A	SGMGH-75D□, SGMGV-75D□	-	-	-	
11 kW	SGDV-280D01A	SGMGH-1AD□, SGMGV-1AD□	-	-	-		
15 kW	SGDV-370D01A	SGMGH-1ED□, SGMGV-1ED□	-	-	-		

### Control cables (for CN1)

Symbol	Description	Connect to	Model
④	Servo relay unit	CJ1W-NC1□□3	XW2B-20J6-1B (1 axis)
		CJ1W-NC2□□3/4□□3	XW2B-40J6-2B (2 axis)
		CJ1M-CPU22/23	XW2B-20J6-8A (1 axis)
			XW2B-40J6-9A (2 axis)
⑤	Cable to servo drive	Servo relay units XW2B-□□J6-□□B	1 m XW2Z-100J-B4
			2 m XW2Z-200J-B4
⑥	Position control unit connecting cable	CJ1W-NC113	0.5 m XW2Z-050J-A14
			1 m XW2Z-100J-A14
		CJ1W-NC213/413	0.5 m XW2Z-050J-A15
			1 m XW2Z-100J-A15
		CJ1W-NC133	0.5 m XW2Z-050J-A18
			1 m XW2Z-100J-A18
		CJ1W-NC233/433	0.5 m XW2Z-050J-A19
			1 m XW2Z-100J-A19
		CJ1M-CPU22/23	0.5 m XW2Z-050J-A27
			1 m XW2Z-100J-A27
⑦	Control cable	For general purpose controllers	1 m R88A-CPW001S
			2 m R88A-CPW002S
⑧	Relay terminal block cable	General purpose controller	1 m R88A-CTW001N
			2 m R88A-CTW002N
	Relay terminal block		- XW2B-50G5

### Battery backup for absolute encoder (for CN2 encoder cable)

Symbol	Name	Model
⑨	Battery	JZSP-BA01

**Note:** When the encoder cables with a battery case are used, no battery is required for CN1 (between pin 21 and 22). Battery for CN1 is ER6VCN3.

### Cable (for CN5)

Symbol	Name	Model
⑩	Analog monitor cable	R88A-CMW001S
		DE9404559

### USB personal computer cable (for CN7)

Symbol	Name	Note
⑪	USB Mini Connector cable	JZSP-CVS06-02-E

**Note:** Double shield USB cable recommended

### Cable for Safety Functions (for CN8)

Symbol	Name	Model
⑫	Safety connector with 3 m cable (with Loose Wires at one End)	JZSP-CVH03-03-E

**Note:** When using the safety function, connect this cable to the safety devices. Even when not using the safety function, use servo drive with the Safe Jumper Connector (JZSP-CVH05-E) connected.

### Filters

Symbol	Applicable servo drive	Filter model	Rated current	Rated voltage
⑬	SGDV-R70A□□□A, -R90A□□□A, -1R6A□□□A, -2R8A□□□A	R88A-FI5-1005-RE	5 A	250 VAC single-phase
	SGDV-5R5A□□□A	R88A-FI5-1009-RE	9 A	
	SGDV-120A□□□A008000	R88A-FI5-1016-RE	16 A	
	SGDV-1R9D□□□A, -3R5D□□□A, -5R4D□□□A	R88A-FI5-3004-RE	4.3 A	400 VAC three-phase
	SGDV-8R4D□□□A, -120D□□□A	R88A-FI5-3008-RE	8.6 A	
	SGDV-170D□□□A	R88A-FI5-3012-RE	14.5 A	

### Connectors

Specifications	Model
I/O connector kit (for CN1)	R88A-CNU11C
Sigma-5 drive encoder connector (for CN2)	JZSP-CMP9-1
Safe Jumper Connector	JZSP-CVH05-E

### Computer software

Specifications	Model
Configuration and monitoring software tool for servo drives and inverters. (CX-Drive version 1.50 or higher)	CX-Drive
Complete OMRON software package including CX-Drive. (CX-One version 3.0.2 or higher)	CX-One

Ordering information

Sigma-5 MECHATROLINK-II Servo Drive Configuration

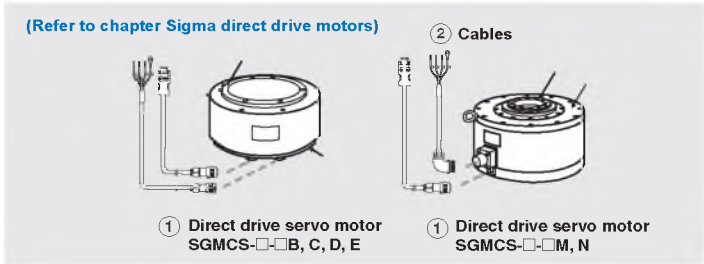
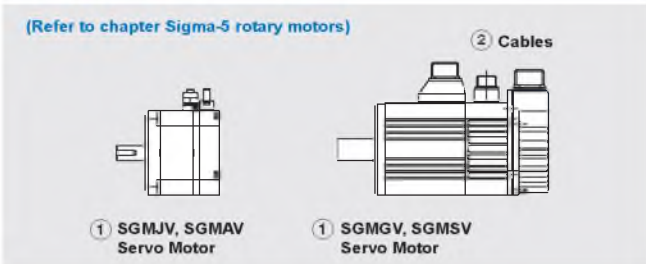
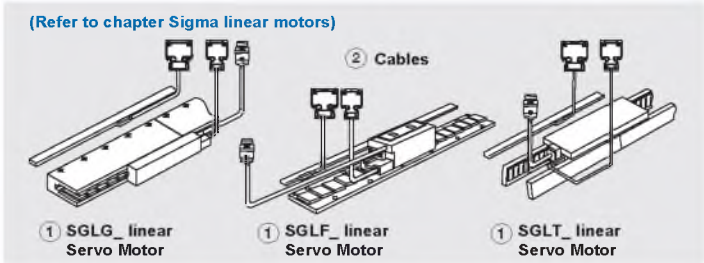
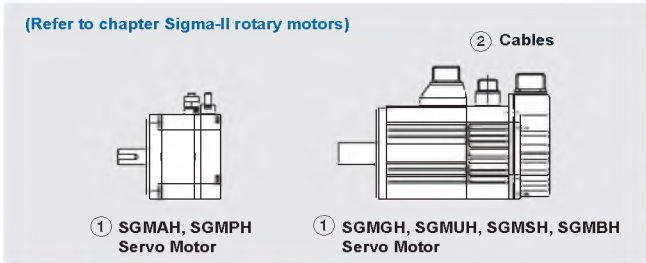
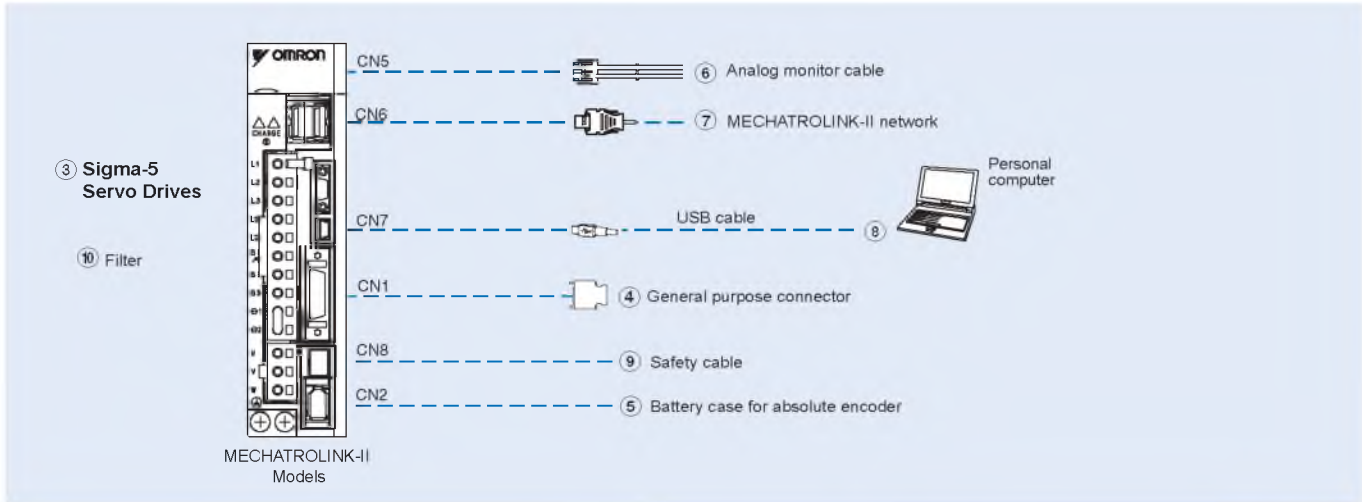

**Note:** The symbols ①②③④⑤... show the recommended sequence to select the components in a Sigma-5 servo system

Servo motors, power & encoder cables

**Note:** ①② Refer to the servo motors chapter for detailed motor specifications and selection



Servo drives

Symbol	Specifications	Model	Compatible rotary servo motors ①	Compatible direct drive motors ①	Compatible linear motors ①		
③	1 phase 230 VAC	50 W	SGDV-R70A11A	SGMAH-A5D□, SGMJV-A5A□, SGMAV-A5A□	-	-	
			SGDV-R70A15A	-	-	SGLGW-30A050□	
		100 W	SGDV-R90A11A	SGMAH-01A□, SGMPH-01A□, SGMJV-01A□, SGMAV-01A□, SGMEV-01A□	*	-	-
			SGDV-R90A15A	-	-	SGLGW-30A080□, SGLGW-40A140□	
		200 W	SGDV-1R6A11A	SGMAH-02A□, SGMPH-02A□, SGMJV-02A□, SGMAV-02A□, SGMEV-02A□	SGMCS-07B□	-	-
			SGDV-1R6A15A	-	-	SGLGW-60A140□, SGLGW-40A253□, SGLFW-20A□, SGLFW-35A120□	
		400 W	SGDV-2R8A11A	SGMAH-04A□, SGMPH-04A□, SGMJV-04A□, SGMAV-04A□, SGMEV-04A□	SGMCS-02B□, SGMCS-05B□, SGMCS-04C□, SGMCS-10C□, SGMCS-14C□, SGMCS-08D□, SGMCS-17D□, SGMCS-25D□	-	-
			SGDV-2R8A15A	-	-	SGLGW-40A365□, SGLGW-60A253A□	
		750 W	SGDV-5R5A11A	SGMAH-08A□, SGMPH-08A□, SGMJV-08A□, SGMAV-08A□, SGMEV-08A□	SGMCS-16E□, SGMCS-35E□	-	-
			SGDV-5R5A15A	-	-	SGLGW-60A365A□, SGLFW-35A230□, SGLFW-50A200□	
		1.5 kW	SGDV-120A11A008000	SGMPH-15A□, SGMAV-10A□, SGMEV-15A□	SGMCS-45M□, SGMCS-80M□, SGMCS-80N□	-	-
			SGDV-120A15A008000	-	-	SGLGW-90A200A□, SGLFW-50A380□, SGLFW-1ZA200□	
	3 phase 400 VAC	0.5 kW	SGDV-1R9D11A	SGMAH-03D□, SGMPH-04D□, SGMGH-05D□, SGMEV-04D□, SGMGV-05D□	*	-	
			SGDV-1R9D15A	-	-	SGLFW-35D□	
		1.0 kW	SGDV-3R5D11A	SGMAH-07D□, SGMPH-08D□, SGMGH-09D□, SGMSH-10D□, SGMUH-10D□, SGMEV-08D□, SGMGV-09D□, SGMSV-10D□,	*	-	-
			SGDV-3R5D15A	-	-	SGLFW-50D200□, SGLTW-35D170□, SGLTW-50D170□	
		1.5 kW	SGDV-5R4D11A	SGMPH-15D□, SGMGH-13D□, SGMSH-15D□, SGMUH-15D□, SGMEV-15D□, SGMGV-13D□, SGMSV-15D□	-	-	-
			SGDV-5R4D15A	-	-	SGLFW-50D380□, SGLFW-1ZD200□	
		2 kW	SGDV-8R4D11A	SGMGH-20D□, SGMSH-20D□, SGMGV-20D□, SGMSV-20D□	-	-	-
			SGDV-8R4D15A	-	-	SGLFW-1ED380□, SGLTW-35D320□, SGLTW-50D320□	
		3 kW	SGDV-120D11A	SGMGH-30D□, SGMSH-30D□, SGMUH-30D□, SGMGV-30D□, SGMGV-30D□	-	-	-
			SGDV-120D15A	-	-	SGLFW-1ZD380□, SGLFW-1ED560□, SGLTW-40D400□	
		5 kW	SGDV-170D11A	SGMGH-44D□, SGMSH-50D□, SGMUH-40D□, SGMGV-44D□, SGMSV-50D□	-	-	-
			SGDV-170D15A	-	-	SGLTW-40D60□, SGLTW-80D400□	
		6 kW	SGDV-210D11A	SGMGH-55D□, SGMGV-55D□	-	-	-
		7.5 kW	SGDV-260D11A	SGMGH-75D□, SGMGV-75D□	-	-	-
		11 kW	SGDV-280D11A	SGMGH-1AD□, SGMGV-1AD□	-	-	-
		15 kW	SGDV-370D11A	SGMGH-1ED□, SGMGV-1ED□	-	-	-

## Battery backup for absolute encoder (for CN2 encoder cable)

Symbol	Name	Model
⑤	Battery	JZSP-BA01

**Note:** When the encoder cables with a battery case JZSP-BA01 are used, no battery is required for CN1 (between pin 21 and 22). Battery for CN1 is ER6VCN3.

## Cable (for CN5)

Symbol	Name	Model
⑥	Analog monitor cable	R88A-CMW001S DE9404559

## Mechatrolink-II cables (for CN6)

Symbol	Specifications	Length	Model
⑦	Mechatrolink-II Terminator resistor		JEPMC-W6022
	Mechatrolink-II Cables	0.5 m	JEPMC-W6003-A5
		1 m	JEPMC-W6003-01
		3 m	JEPMC-W6003-03
		5 m	JEPMC-W6003-05
		10 m	JEPMC-W6003-10
		20 m	JEPMC-W6003-20
30 m	JEPMC-W6003-30		

## Filters

Symbol	Applicable servo drive	Filter model	Rated current	Rated voltage
⑩	SGDV-R70A□□□A, -R90A□□□A, -1R6A□□□A, -2R8A□□□A	R88A-FI5-1005-RE	5 A	250 VAC single-phase
	SGDV-5R5A□□□A	R88A-FI5-1009-RE	9 A	
	SGDV-120A□□□A008000	R88A-FI5-1016-RE	16 A	
	SGDV-1R9D□□□A, -3R5D□□□A, -5R4D□□□A	R88A-FI5-3004-RE	4.3 A	400 VAC three-phase
	SGDV-8R4D□□□A, -120D□□□A	R88A-FI5-3008-RE	8.6 A	
	SGDV-170D□□□A	R88A-FI5-3012-RE	14.5 A	

## Connectors

Specification	Model
I/O connector kit (for CN1)	R88A-CNW01C
Sigma-5 drive encoder connector (for CN2)	JZSP-CMP9-1
Safe Jumper Connector	JZSP-CVH05-E

## Computer software

Specifications	Model
Configuration and monitoring software tool for servo drives and inverters. (CX-Drive version 1.50 or higher)	CX-Drive
Complete OMRON software package including CX-Drive. (CX-One version 3.0.2 or higher)	CX-One

## USB personal computer cable (for CN7)

Symbol	Name	Note
⑧	USB Mini Connector cable	JZSP-CVS06-02-E

**Note:** Double shield USB cable recommended

## Cable for Safety Functions (for CN8)

Symbol	Name	Model
⑨	Safety connector with 3 m cable (with Loose Wires at one End)	JZSP-CVH03-03-E

**Note:** When using the safety function, connect this cable to the safety devices. Even when not using the safety function, use servo drive with the Safe Jumper Connector (JZSP-CVH05-E) connected.

ALL DIMENSIONS SHOWN ARE IN MILLIMETERS.  
To convert millimeters into inches, multiply by 0.03937. To convert grams into ounces, multiply by 0.03527.

**По вопросам продаж и поддержки обращайтесь:**

Архангельск (8182)63-90-72  
Астана +7(7172)727-132  
Белгород (4722)40-23-64  
Брянск (4832)59-03-52  
Владивосток (423)249-28-31  
Волгоград (844)278-03-48  
Вологда (8172)26-41-59  
Воронеж (473)204-51-73  
Екатеринбург (343)384-55-89  
Иваново (4932)77-34-06  
Ижевск (3412)26-03-58  
Казань (843)206-01-48

Калининград (4012)72-03-81  
Калуга (4842)92-23-67  
Кемерово (3842)65-04-62  
Киров (8332)68-02-04  
Краснодар (861)203-40-90  
Красноярск (391)204-63-61  
Курск (4712)77-13-04  
Липецк (4742)52-20-81  
Магнитогорск (3519)55-03-13  
Москва (495)268-04-70  
Мурманск (8152)59-64-93  
Набережные Челны (8552)20-53-41

Нижегород (831)429-08-12  
Новокузнецк (3843)20-46-81  
Новосибирск (383)227-86-73  
Орел (4862)44-53-42  
Оренбург (3532)37-68-04  
Пенза (8412)22-31-16  
Пермь (342)205-81-47  
Ростов-на-Дону (863)308-18-15  
Рязань (4912)46-61-64  
Самара (846)206-03-16  
Санкт-Петербург (812)309-46-40  
Саратов (845)249-38-78

Смоленск (4812)29-41-54  
Сочи (862)225-72-31  
Ставрополь (8652)20-65-13  
Тверь (4822)63-31-35  
Томск (3822)98-41-53  
Тула (4872)74-02-29  
Тюмень (3452)66-21-18  
Ульяновск (8422)24-23-59  
Уфа (347)229-48-12  
Челябинск (351)202-03-61  
Череповец (8202)49-02-64  
Ярославль (4852)69-52-93