

MICROHAWK® MV-30

SPECIFICATIONS AND OPTIONS



Ultra-Compact
 Height: 25 mm (0.98")
 Width: 45 mm (1.77")
 Length: 38 mm (1.50")

Integrated LEDs

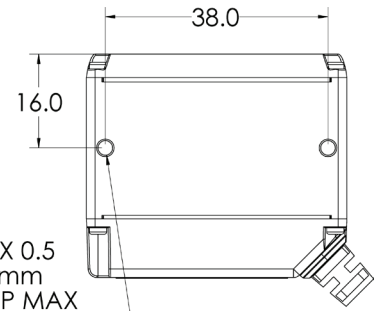
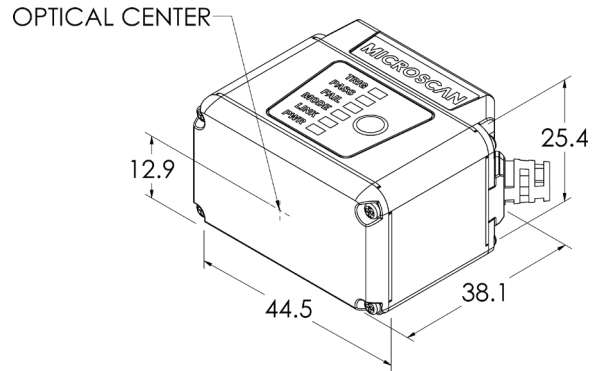

M3 X 0.5
 5.0 mm
 DEEP MAX
 2 PLACES

Note: Nominal dimensions in MM are shown. Typical tolerances apply.

DIMENSIONS

Height: 25 mm (0.98")
Width: 45 mm (1.77")
Length: 38 mm (1.50")
Weight without Cable: 46 g (1.62 oz.)

ENCLOSURE: IP54, Aluminum

ENVIRONMENTAL

Operating Temperature: 0° to 40° C (32° to 104° F)
Storage Temperature: -50° to 75° C (-58° to 167° F)
Humidity: 5% to 95% (non-condensing)

EMISSIONS

EN 61326-1:2013 Class A Limits

ELECTRICAL

5 VDC ± 5%, 600 mA at 5 VDC (typ.)

CONNECTOR

0.91 m Cable with High-Density 15-Pin D-Sub Socket

COMMUNICATION

USB 2.0 Full-Speed (Ethernet over USB and HID), RS-232

DISCRETE I/O

2 in/3 out: Trigger Input; New Master Input: 5-28 V rated (0.16 mA @ 5 VDC); Strobe Output; 2 General Purpose Outputs: 5V TTL-compatible, can sink 10 mA and source 10 mA

ILLUMINATION

Inner Red: 4 LEDs, 625 nm nominal
Inner White: 4 LEDs
Outer Red, White, Blue, or IR: 8 LEDs
Light Modes: Inner or Outer; Off, On, Strobe, Power Strobe; Power Strobe for Outer LEDs only. Not available when running under USB power.

INDICATORS

TRIG, PASS, FAIL, MODE, LINK, PWR LEDs, 2 Target Pattern LEDs, 2 Inspection Passed Green Flash LEDs

MEMORY

2 GB Non-Volatile Flash, 256 MB RAM

SPEED: 800 MHz

SOFTWARE

AutoVISION Sensor, AutoVISION, Visionscape

FTP IMAGE STORAGE: Supported

SENSOR OPTIONS

WVGA (Mono): CMOS 0.34 MP (752 x 480), 4.51 x 2.88 mm, 6 µm pixel size
SXGA (Mono): CMOS 1.2 MP (1280 x 960), 4.80 x 3.60 mm, 3.75 µm pixel size
QSXGA (Color): CMOS 5 MP (2592 x 1944), 4.536 x 3.402 mm, 1.75 µm pixel size

SHUTTER

Global (WVGA, SXGA), Rolling (QSXGA)

EXPOSURE

WVGA: 50 to 66,667 µs; **SXGA:** 66 to 58,825 µs;
QSXGA: 66 to 66,667 µs

OPTICS

Fixed: Standard Density (5.2 mm), High-Density (8.0 mm), UHD (16.0 mm)
Autofocus: Standard Density (5.2 mm), High-Density (7.7 mm), UHD (16.0 mm)

FOCUS

Fixed: Factory Set to 50, 102, 190 or 300 mm (SD, HD); 64 or 400 mm (UHD)
Autofocus: Software Adjustable 50 to 300 mm (SD, HD); 40 to 150 mm (UHD)

FRAMES PER SECOND

WVGA: Up to 52; **SXGA:** Up to 40;
QSXGA: Up to 5

SYMBOLOGIES

2D: Data Matrix (ECC 0-200), QR Code, Micro QR Code, Aztec Code
Stacked: PDF417, MicroPDF417, GS1 Databar (Composite and Stacked)
Linear: Code 39, Code 128, BC412, Interleaved 2 of 5, UPC/EAN, Codabar, Code 93, Pharmacode, PLANET, POSTNET, Japanese Postal, Australia Post, Royal Mail, Intelligent Mail, KIX

SAFETY AND QUALITY

FCC, CE, UL, RoHS-Compliant

QMS CERTIFICATION

www.microscan.com/quality

PIN ASSIGNMENTS

High-Density 15-Pin D-Sub Socket

Pin	Function
1	+5VDC
2	TX232
3	RX232
4	GND
5	D+
6	N/C
7	Output 1+
8	Default+
9	Trigger+
10	D-
11	Output 3+
12	New Master+
13	N/C
14	Output 2+
15	Vbus

Note: Accessory cable required between 15-pin socket and host USB port.

MICROHAWK® MV-30 FIELD OF VIEW AND READ RANGE CHARTS

WVGA High-Density and Standard Density Fixed Focus

Focus Distance		WVGA HIGH-DENSITY						WVGA STANDARD DENSITY					
		Field of View		Typical 2D Mil Size	Depth of Field (mm)		Min. 2D Mil Size	Field of View		Typical 2D Mil Size	Depth of Field (mm)		Min. 2D Mil Size
in.	mm	in.	mm	mil size	Inside	Outside	mil size	in.	mm	mil size	Inside	Outside	mil size
2.0	50	1.4	35	7.5	43	58	5	2.0	50	10	38	65	7.5
4.0	102	2.6	65	10	83	121	10	3.7	94	20	52	152	15
7.5	190	4.5	114	20	133	246	15	6.5	165	30	128	252	20
11.8	300	7.1	180	30	179	422	30	10.2	260	40	219	381	30

Example Read Range

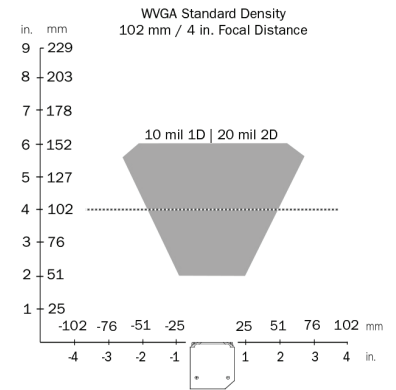

SXGA High-Density and Standard Density Fixed Focus

Focus Distance		SXGA HIGH-DENSITY						SXGA STANDARD DENSITY					
		Field of View		Typical 2D Mil Size	Depth of Field (mm)		Min. 2D Mil Size	Field of View		Typical 2D Mil Size	Depth of Field (mm)		Min. 2D Mil Size
in.	mm	in.	mm	mil size	Inside	Outside	mil size	in.	mm	mil size	Inside	Outside	mil size
2.0	50	1.5	37	5	47	55	3.3	2.1	53	7.5	37	64	5
4.0	102	2.7	69	7.5	88	116	5	3.9	100	10	74	131	7.5
7.5	190	4.8	122	15	137	243	10	6.9	175	15	115	265	15
11.8	300	7.6	192	20	185	400	15	10.9	277	20	224	427	20

Example Read Range

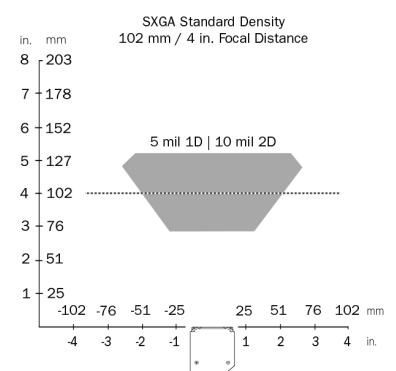

QSXGA High-Density and Standard Density Fixed Focus

Focus Distance		QSXGA HIGH-DENSITY						QSXGA STANDARD DENSITY					
		Field of View		Typical 2D Mil Size	Depth of Field (mm)		Min. 2D Mil Size	Field of View		Typical 2D Mil Size	Depth of Field (mm)		Min. 2D Mil Size
in.	mm	in.	mm	mil size	Inside	Outside	mil size	in.	mm	mil size	Inside	Outside	mil size
2.0	50	1.4	35	5	46	55	3.3	2.0	51	5	43	59	3.3
4.0	102	2.6	66	5	94	110	3.3	3.8	96	7.5	80	124	5
7.5	190	4.6	116	10	154	227	7.5	6.6	168	10	150	231	10
11.8	300	7.2	184	15	227	373	10	10.4	265	15	203	397	15

Example Read Range

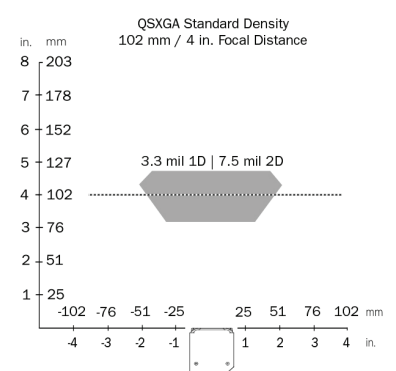

SXGA Ultra-High-Density Fixed Focus

SXGA UHD - 64 MM					
Min. 1D Element	Depth of Field (mm)		Field of View		
	Inside	Outside	Hor.	Vert.	
2	63.5	64.5	16.5	12.5	
2.5	62.5	66			
3	62.5	66			
3.3	62.5	67			

SXGA UHD - 400 MM					
Min. 2D Element	Depth of Field (mm)		Field of View		
	Inside	Outside	Hor.	Vert.	
7.5	360	415	114	86	
10	351	429			
15	325	451			
20	309	466			
30	293	512			
40	303	563			

Note: Minimum 1D element is typically 1/2 the size of minimum 2D element.
Example: 10 mil 2D = 5 mil 1D.

MICROHAWK® MV-30 FIELD OF VIEW AND READ RANGE CHARTS

WVGA High-Density and Standard Density Autofocus

Object Distance Std Models		WVGA HIGH-DENSITY AUTOFOCUS			
		Horizontal Field of View		Vertical Field of View	
in.	mm	in.	mm	in.	mm
2.0	50	1.3	33.5	0.8	21.5
2.5	64	1.7	42.0	1.0	26.5
3.2	81	2.1	52.5	1.3	33.0
4.0	102	2.6	65.0	1.6	41.0
5.2	133	3.3	84.5	2.1	53.5
7.5	190	4.7	119.5	3.0	75.0
11.8	300	7.4	187.0	4.6	117.0

Object Distance Std Models		WVGA STANDARD DENSITY AUTOFOCUS			
		Horizontal Field of View		Vertical Field of View	
in.	mm	in.	mm	in.	mm
2.0	50	2.1	52.5	1.3	34.0
2.5	64	2.6	65.5	1.6	41.5
3.2	81	3.2	82.0	2.0	51.0
4.0	102	4.0	102.0	2.5	64.0
5.2	133	5.2	132.0	3.2	82.0
7.5	190	7.3	185.0	4.5	115.5
11.8	300	11.3	288.0	7.1	180.0

Symbol Size (mils)	WVGA High-Density Read Range Testings			
	IE (mm)	PPE	OE (mm)	PPE
3.3	50	1.9	53	1.8
5	50	2.8	57	2.5
7.5	50	4.2	61	3.6
10	50	5.6	64	4.6
15	50	8.5	71	6.3

Symbol Size (mils)	WVGA Standard Density Read Range Testings			
	IE (mm)	PPE	OE (mm)	PPE
5	50	1.8	60	1.5
7.5	50	2.7	69	2
10	50	3.6	77	2.5
15	50	5	92	3.1
20	50	7.2	99	4

SXGA High-Density and Standard Density Autofocus

Object Distance Std Models		SXGA HIGH-DENSITY AUTOFOCUS			
		Horizontal Field of View		Vertical Field of View	
in.	mm	in.	mm	in.	mm
2.0	50	1.4	36.5	1.1	27.4
2.5	64	1.8	46.0	1.4	34.5
3.2	81	2.3	57.2	1.7	42.9
4.0	102	2.8	71.4	2.1	53.6
5.2	133	3.6	90.5	2.7	67.9
7.5	190	5.0	127.0	3.8	95.3
11.8	300	7.8	198.4	5.9	148.8

Object Distance Std Models		SXGA STANDARD DENSITY AUTOFOCUS			
		Horizontal Field of View		Vertical Field of View	
in.	mm	in.	mm	in.	mm
2.0	50	2.3	57.2	1.7	42.9
2.5	64	2.9	73.0	2.2	54.8
3.2	81	3.5	88.9	2.6	66.7
4.0	102	4.3	109.5	3.2	82.2
5.2	133	5.6	141.3	4.2	106.0
7.5	190	7.9	200.0	5.9	150.0
11.8	300	12.4	314.3	9.3	235.7

Symbol Size (mils)	SXGA High-Density Read Range Testings			
	IE (mm)	PPE	OE (mm)	PPE
3.3	50	3.0	NA	NA
5	50	4.6	144	1.7
7.5	50	6.8	208	1.8
10	50	9.2	291	1.7
15	50	13.9	374	2

Symbol Size (mils)	SXGA Standard Density Read Range Testings			
	IE (mm)	PPE	OE (mm)	PPE
5	50	2.7	94	1.6
7.5	50	4.4	143	1.7
10	50	5.6	186	1.7
15	50	8.7	282	1.7
20	50	11.5	308	2.1

SXGA Ultra-High-Density Autofocus

SXGA UHD AUTOFOCUS			
Min. 2D Element	Horizontal Field of View (mm)		Read Range (mm)
	Inside	Outside	
mil size	Inside	Outside	Autofocus
2	10	24	40 - 104
3.3	10	36	40 - 146
5	10	39	40 - 150

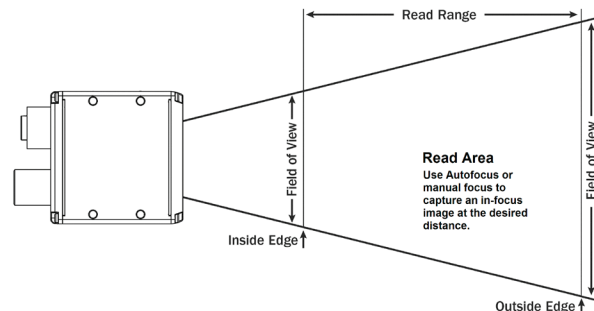

По вопросам продаж и поддержки обращайтесь:

Архангельск (8182)63-90-72	Казань (843)206-01-48	Новокузнецк (3843)20-46-81	Смоленск (4812)29-41-54
Астана +7(7172)727-132	Калининград (4012)72-03-81	Новосибирск (383)227-86-73	Сочи (862)225-72-31
Астрахань (8512)99-46-04	Калуга (4842)92-23-67	Омск (3812)21-46-40	Ставрополь (8652)20-65-13
Барнаул (3852)73-04-60	Кемерово (3842)65-04-62	Орел (4862)44-53-42	Сургут (3462)77-98-35
Белгород (4722)40-23-64	Киров (8332)68-02-04	Оренбург (3532)37-68-04	Тверь (4822)63-31-35
Брянск (4832)59-03-52	Краснодар (861)203-40-90	Пенза (8412)22-31-16	Томск (3822)98-41-53
Владивосток (423)249-28-31	Красноярск (391)204-63-61	Пермь (342)205-81-47	Тула (4872)74-02-29
Волгоград (844)278-03-48	Курск (4712)77-13-04	Ростов-на-Дону (863)308-18-15	Тюмень (3452)66-21-18
Вологда (8172)26-41-59	Липецк (4742)52-20-81	Рязань (4912)46-61-64	Ульяновск (8422)24-23-59
Воронеж (473)204-51-73	Магнитогорск (3519)55-03-13	Самара (846)206-03-16	Уфа (347)229-48-12
Екатеринбург (343)384-55-89	Москва (495)268-04-70	Санкт-Петербург (812)309-46-40	Хабаровск (4212)92-98-04
Иваново (4932)77-34-06	Мурманск (8152)59-64-93	Саратов (845)249-38-78	Челябинск (351)202-03-61
Ижевск (3412)26-03-58	Набережные Челны (8552)20-53-41	Севастополь (8692)22-31-93	Череповец (8202)49-02-64
Иркутск (395) 279-98-46	Нижний Новгород (831)429-08-12	Симферополь (3652)67-13-56	Ярославль (4852)69-52-93

Киргизия (996)312-96-26-47 Казахстан (772)734-952-31 Таджикистан (992)427-82-92-69

Эл. почта: orm@nt-rt.ru || Сайт: <http://omron.nt-rt.ru>