

Контроллеры автономные серии MP2300

ТЕХНИЧЕСКИЕ ХАРАКТЕРИСТИКИ

По вопросам продаж и поддержки обращайтесь:

Архангельск (8182)63-90-72
Астана +7(7172)727-132
Белгород (4722)40-23-64
Брянск (4832)59-03-52
Владивосток (423)249-28-31
Волгоград (844)278-03-48
Вологда (8172)26-41-59
Воронеж (473)204-51-73
Екатеринбург (343)384-55-89
Иваново (4932)77-34-06
Ижевск (3412)26-03-58
Казань (843)206-01-48

Калининград (4012)72-03-81
Калуга (4842)92-23-67
Кемерово (3842)65-04-62
Киров (8332)68-02-04
Краснодар (861)203-40-90
Красноярск (391)204-63-61
Курск (4712)77-13-04
Липецк (4742)52-20-81
Магнитогорск (3519)55-03-13
Москва (495)268-04-70
Мурманск (8152)59-64-93
Набережные Челны (8552)20-53-41

Нижний Новгород (831)429-08-12
Новокузнецк (3843)20-46-81
Новосибирск (383)227-86-73
Орел (4862)44-53-42
Оренбург (3532)37-68-04
Пенза (8412)22-31-16
Пермь (342)205-81-47
Ростов-на-Дону (863)308-18-15
Рязань (4912)46-61-64
Самара (846)206-03-16
Санкт-Петербург (812)309-46-40
Саратов (845)249-38-78

Смоленск (4812)29-41-54
Сочи (862)225-72-31
Ставрополь (8652)20-65-13
Тверь (4822)63-31-35
Томск (3822)98-41-53
Тула (4872)74-02-29
Тюмень (3452)66-21-18
Ульяновск (8422)24-23-59
Уфа (347)229-48-12
Челябинск (351)202-03-61
Череповец (8202)49-02-64
Ярославль (4852)69-52-93

MP2300 - MECHATROLINK-II

Motion controller

Stand-alone solution for advanced motion control

- Up to 48 axes controlled with minimum wiring
- Self configuration of nodes for an easy setup
- DeviceNet, PROFIBUS and ethernet network interfaces provide easy connectivity to any system
- Supports position, speed and torque control
- Electronic CAM profiles and axes synchronization
- The high-speed bus MECHATROLINK-II is specially designed for motion control
- Support for I/Os and pulse inputs locally and over the network
- Access to the complete system from one point.



System configuration

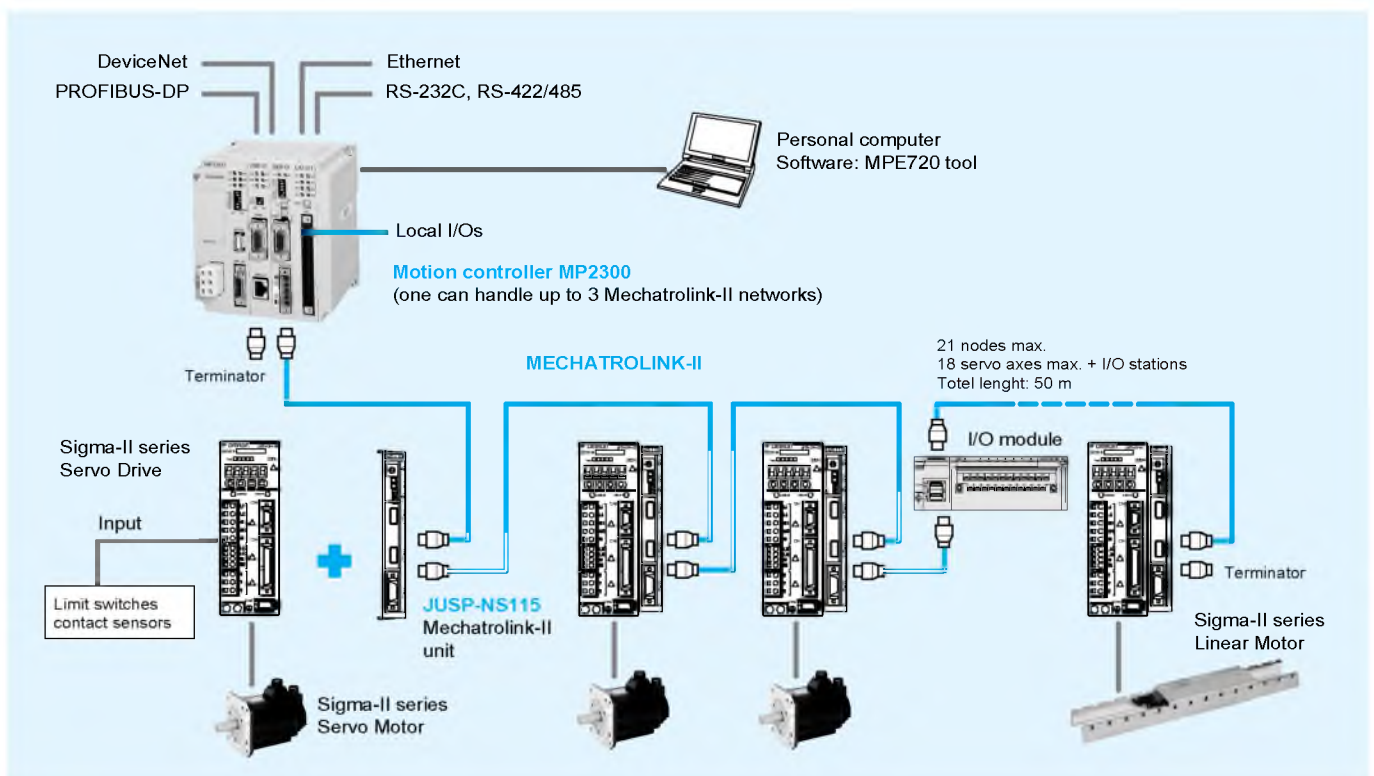

Specifications

General specifications

Hardware specifications

Items	Specifications	
Environmental conditions	Ambient operating temperature	0 to 55 °C
	Ambient storage temperature	-25 to 85 °C
	Ambient operating humidity	30% to 95% (with no condensation)
	Ambient storage humidity	5% to 95% (with no condensation)
	Pollution level	Pollution level 1 (conforming to JIS B 3501)
	Corrosive gas	There must be no combustible or corrosive gas.
	Operating altitude	2,000 m above sea level or lower
Mechanical operating conditions	Vibration resistance	Conforming to JIS B 3502: 10 to 57 Hz with single-amplitude of 0.075 mm 57 to 150 Hz with acceleration of 1G 10 sweeps each in X, Y, and Z directions (sweep time: 1 octave/decade)
	Shock resistance	Conforming to JIS B 3502: Peak acceleration of 147 m/s ² (15 G) twice for 11 ms each in the X, Y, and Z directions
Electrical operating conditions	Noise resistance	Conforming to EN 61000-6-2, EN 55011 (Group 1, Class A)
Installation requirements	Ground	Ground to 100 Ω max.
	Cooling method	Natural cooling

Sequential function specifications

Items	Specifications	
Control method	Sequence: High-speed and low-speed scan methods	
Programming language	Ladder diagram: Relay circuit	
	Text-type language: Numeric operations, logic operations,	
Scanning	Two scan levels: High-speed scan and low-speed scan	
	High-speed scan time setting: 1 to 32 ms (Integral multiple of MECHATROLINK communication cycle)	
	Low-speed scan time setting: 2 to 300 ms (Integral multiple of MECHATROLINK communication cycle)	
User drawings, functions and motion programs	Startup drawings (DWG.A):	64 drawings max. up to three hierarchical drawing levels
	Interrupt processing drawings (DWG.I):	64 drawings max. up to three hierarchical drawing levels
	High-speed scan process drawings (DWG.H):	200 drawings max. up to three hierarchical drawing levels
	Low-speed scan process drawings (DWG.L):	Number of steps: 500 drawings max. up to three hierarchical drawing levels
	User functions:	Up to 1,000 steps per drawing
	Motion programs:	Up to 500 functions
Data memory	Revision history of drawings and motion programs	Up to 256
	Security function for drawings and motion	
	Output (O) registers: Constant (C) registers:	64 Kwords
	System (S) registers: Drawing local (D) registers: Drawing constant (#) registers: Input (I) registers:	8 Kwords
	Output (O) registers: Constant (C) registers:	Up to 16 Kwords per drawing
	Output (O) registers: Constant (C) registers:	Up to 16 Kwords per drawing
Trace memory	Data trace: 128 Kwords (32 Kwords, 4 groups), 16 points defined	
Memory backup	Program memory: Flash memory: 8 MBytes (user area: 5.5 MBytes) definition files, ladder programs, motion programs, etc.	
	Data memory: Battery backup: 256 Kbytes, M registers, S registers, alarm history, trace data	
Data types	Bit (relay): ON/OFF	
	Integer: -32768 to +32767	
	Double-length integer: -2147483648 to +2147483647	
	Real number: ± (1.175E-38 to 3.402E+38)	
Register designation method	Register number: Direct designation of register number	
	Symbolic designation: Up to 8 alphanumeric characters (up to 200 symbols per drawing) With automatic number or symbol assignment	

Motion control function specifications

Item	Specifications		
Interface	MECHATROLINK-I, MECHATROLINK-II		
Number of controlled axes/module	Up to 16 axes		
Control specifications	PTP control	Linear, rotary, and infinite-length	
	Interpolation	Up to 16 linear axes, 2 circular axes, and 3 helical axes	
	Speed reference output	Yes	
	Torque reference output	Yes	
	Phase control	Yes	
	Position control	Positioning	Yes
		External positioning	Yes
		Zero point return	Yes
		Interpolation	Yes
		Interpolation with position detection function	Yes
JOG operation		Yes	
STEP operation		Yes	
Parameter changes during motion command execution	Yes		
Reference unit	mm, inch, deg, or pulse		
Reference unit minimum setting	1, 0.1, 0.01, 0.001, 0.0001, 0.00001		
Maximum programmable value	-2147483648 to +2147483647 (signed 32-bit value)		
Speed reference unit	Reference unit/s designation: mm/s, inch/s, deg/s, pulse/s Reference unit/min. designation: mm/min, inch/min, deg/min, pulse/min Percentage designation: Percentage of rated speed		
Acceleration/deceleration type	Linear, asymmetric, S-curve, exponent		
Acceleration/deceleration reference unit	Reference unit/s ² designation: mm/s ² , inch/s ² , deg/s ² , pulse/s ² Acceleration/deceleration time constant: Time from 0 to rated speed		
Override function	Positioning: 0.01% to 327.67% by axis		
Coordinate system	Rectangular coordinates		
Zero point return	DEC1+ phase-C pulse	Yes	
	ZERO signal	Yes	
	DEC1+ ZERO signal	Yes	
	Phase-C pulse	Yes	
	Only phase-C pulse	Yes	
	POT and phase-C pulse	Yes	
	POT	Yes	
	Home limit switch and phase-C pulse	Yes	
	HOME	Yes	
	NOT and phase-C pulse	Yes	
	NOT	Yes	
	INPUT and phase-C pulse	Yes	
INPUT	Yes		
Applicable servo drives	SGDH-@@@E-OY + NS115		
Applicable frequency inverters	Varispeed V7, F7, G7 with MECHATROLINK-II interface (for inverter version support contact your OMRON sales office)		
Encoders	Incremental encoder Yaskawa absolute encoder		

MP2300 CPU (basic module)

Items	Specifications	Appearance
Model	JEPMC-MP2300	
Power supply	Input power voltage: 24 VDC±20% Current consumption: 1 A Inrush current: 40 A or less	
Motion network	One channel for MECHATROLINK-II: Twenty-one stations, including servo drives and I/O equipment, can be connected. (16 axes for servo drives and inverters) Transmission speed: 10Mbps (MECHATROLINK-II) Transmission distance: See "MECHATROLINK-II repeater"	
I/O signals	Digital input: 8 points (one point can be used for interrupts), 24 VDC, 4 mA, and source mode or sink mode input Digital output: 4 points, 24 VDC, 100 mA, open collector, and sink mode output (NPN)	
Slot for optional modules	3 slots	
Dimensions (mm)	130x120x108 (HxWxD)	
Weight	500 g	

General-purpose serial communication module (217IF-01)

Items		Specifications		Appearance
Model		JAPMC-CM2310		
Port		For RS-232C communication	For RS-422/485 communication	
Interface		One port	One port (RS-422 or -485)	
Connector		D-sub 9 pins (female)	MDR 14 pins (female)	
Max. transmission distance		15 m	300 m	
Transmission speed		76.8 kbps	76.8 kbps	
Access mode		Asynchronous (start-stop synchronization)	Asynchronous (start-stop synchronization)	
Communication protocols		MEMOBUS (master or slave) MELSEC, HostLink, or non-protocol	MEMOBUS (master or slave) MELSEC, HostLink, or non-protocol	
Media access control method		1:1	1:1 (RS-422), 1:N (RS-485)	
Transmission format (can be set)		Data bit length: 7 or 8 bits Stop bits: 1 or 2 bits Parity bits: even, odd, or none	Data bit length: 7 or 8 bits Stop bits: 1 or 2 bits Parity bits: even, odd, or none	

Ethernet communication module (218IF-01)

Items		Specifications		Appearance
Model		JAPMC-CM2300		
Port		For ethernet communication	For RS-232C communication	
Interface		One port (10BaseT) (RJ-45 modular jack)	One port	
Max. segment length		100 m	Connector D-sub 9 pins (female)	
Transmission speed		10 Mbps	Max. transmission distance 15 m	
Access mode		IEEE802.3	Transmission speed 76.8 kbps	
Flame format		Ethernet ver.2 (conforming to DIX)	Access mode Asynchronous (Start-stop synchronization)	
Connections		TCP/UDP/IP/ARP	Communication protocols MEMOBUS (master or slave) MELSEC, HostLink, or non-protocol	
Max. number of words in transmission		512 words (1024 bytes)	Media access control method 1:1	
Communication protocols		Extended MEMOBUS, MEMOBUS, MELSEC-A, non-protocol, or MODBUS/TCP	Transmission format (can be set) Data bit length: 7 or 8 bits Stop bits: 1 or 2 bits Parity bits: even, odd, or none	
Max. number of connections		20 stations		

DeviceNet communication module (260IF-01)

Items		Specifications		Appearance
Model		JAPMC-CM2320		
Port		For DeviceNet communication	For RS-232C communication	
Number of circuits		1	Interface One port	
Applicable communication		Conforms to DeviceNet master or slave - I/O transmission - polled I/O and bistrobbed I/O) - Explicit messaging	Connector D-sub 9 pins (female)	
I/O communication	Max. number of slaves	63 nodes	Max. transmission distance 15 m	
	Max. I/O bytes	1024 bytes, 256 bytes per node		
Message communication (only for master)	Max. number of nodes	63 nodes (synchronous communications possible: 8 nodes)	Transmission speed 76.8 kbps	
	Max. message length	256 bytes		
	Executed functions	MSG-SND function	Access mode Asynchronous (start-stop synchronization)	
Switches on the front		Two rotary switches: Node address settings DIP switch: Settings for transmission speed and switching master or slave	Communication protocols MEMOBUS (master or slave) MELSEC, HostLink, or non-protocol	
Indicators		2 LEDs: MS or NS	Media access control method 1:1	
Power voltage for communication		24 VDC±10% (using the specially designed cable)	Transmission format (can be set) Data bit length: 7 or 8 bits Stop bits: 1 or 2 bits Parity bits: even, odd, or none	
Max. current consumption		Communication power: 45 mA (supplied by transmission connectors)		

PROFIBUS communication module (261IF-01)

Items	Specifications		Appearance	
Model	JAPMC-CM2330			
Port	For PROFIBUS communication	Port		For RS-232C communication
Functions	DP slave	Interface		One port
	Cyclic communication (DP standard function)	Connector		D-sub 9 pins (female)
Transmission speed	12M/6M/4M/3M/1.5M/750k/500k/187.5k/93.75k/19.2k/9.6kbps (automatic detection)	Max. transmission distance		15 m
Configuration	By PROFIBUS master			
Slave address	1 to 64	Transmission speed		76.8 kbps
I/O processing	Total capacity of IW/OW registers: 64 words Max. I/O allocation (IN and OUT each): 64 words	Access mode		Asynchronous (start-stop synchronization)
		Communication protocols		MEMOBUS (master or slave) MELSEC, HostLink, or non-protocol
Diagnostic functions	Display for status and slave status using the EWS. I/O error display for SW registers	Media access control method		1:1
		Transmission format (can be set)	Data bit length: 7 or 8 bits Stop bits: 1 or 2 bits Parity bits: even, odd, or none	

Analogue reference motion control module (SVA-01)

Items	Specifications	Appearance
Model	JAPMC-MC2300	
Number of axes	2 axes (CN1 & CN2) analogue output and encoder input.	
Digital inputs (per axis)	6 inputs, PNP or NPN (including alarm, ready, zero and latch)	
Digital outputs (per axis)	6 outputs (including servo_on, alarm_reset, control_mode_select and SEN)	
Encoder input (per axis)	Differential line-driver (A,/A,B,/B,Z,/Z). 4 Mpps (before multiplication).	
Analog outputs (per axis)	2 outputs ±10 V 16 bits (typically speed and torque references)	
Analog inputs (per axis)	2 inputs ±10 V 16 bits	
External supply	24 VDC (in CN3)	
LED's	RUN (green) ERR (red)	

MECHATROLINK-II motion control module (SVB-01)

Items	Specifications	Appearance
Model	JAPMC-MC2310	
Communication circuits	1 circuit	
Communication ports	2 ports	
Terminator	External resistor (JEPMC-VW6022 required)	
Transmission speed	10 Mbps	
Communication cycle	0.5ms, 1ms, 1.5ms, 2ms	
Number of connecting stations	21 stations (16 axes for servo drives and inverters) /2 ms, 15 stations (15 axes for servo drives) /1.5 ms, 9 stations (9 axes for servo drives) /1ms, 4 stations (4 axes for servo drives) /0.5 ms	
Retry function	Available with MECHATROLINK-II	
Slave function	Available with MECHATROLINK-II	
Transmission distance	See "MECHATROLINK-II repeater"	

I/O modules (LIO-01/02)

Items	Specifications	Appearance
Models	JAPMC-IO2300 (NPN output), JAPMC-IO2301 (PNP output)	
Digital I/O		
Input signals	16 points (all connected) and 24 VDC±20%, 5 mA (TYP) Sink mode or source mode input and photocoupler isolation Min. ON voltage/current: 15V/1.6 mA Max. OFF voltage/current: 5V/1.0 mA Max. response time: OFF→ON 1 ms and ON→OFF 1 ms Interruption (DI-00): DI-00 can be used for interruptions. If an interruption is enabled, the interrupt drawing is started when DI-00 is set to ON. Pulse latch (DI-01): DI-01 can be used for pulse latching. If pulse latching is enabled, the pulse counter is latched when DI-01 is set to ON.	
	Output signals	
Pulse input		
Number of channels	1 (Phase A, B, or Z input)	
Input circuit	Phase A/B: 5V differential inputs, no insulation, and max. frequency 4 MHz Phase Z: 5 V/12 V photocoupler inputs and max. frequency 500 kHz	
Input method	A/B (1, 2, or 4 multipliers), sign (1 or 2 multipliers), UP/DOWN (1 or 2 multipliers)	
Latch input	Pulse latch with phase Z or DI-01 Min. response time: 5 μs when input with phase Z; 60 μs when input with	
Others	Overflow detection; preset and clear functions for counter values.	

I/O modules (LIO-04)

Items	Specifications	Appearance
Model	JAPMC-IO2303	
Input signals	<p>32 points (8 points common) and 24 VDC±20%, 5 mA (TYP) Sink mode or source mode input and photocoupler isolation Min. ON voltage/current: 15 V/1.6 mA Max. OFF voltage/current: 5 V/1.0 mA Max. response time: OFF → ON 0.5 ms and ON → OFF 0.5 ms Interruption (DI-00, DI-01, DI-16, DI-17): DI-00, DI-01, DI-16, and DI-17 can be used for interruptions. If an interruption is enabled, the interrupt drawing is started when DI-00, DI-01, DI-16, or DI-17 is set to ON. Note: See right for the derating conditions</p>	
Output signals	<p>32 points (8 points common) and 24 VDC±20%, 100 mA max. Open collector: Sink mode output (NPN) and photocoupler isolation Max. OFF current: 0.1 mA Max. response time: OFF → ON 0.5 ms and ON → OFF 1 ms Output protection: Fuse (for protection against fires caused by an overcurrent when outputting after a short circuit occurred) If circuit protection is required, provide a fuse for each output circuit.</p>	

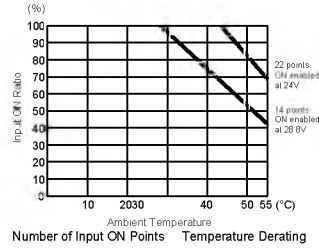

MECHATROLINK-II, 64 point I/O module (IO2310)

Items	Specifications	Appearance
Model	JEPMC-IO2310	
I/O signals	<p>Input: 64 points, 24 VDC, 5 mA, sink/source mode input Output: 64 points, 24 VDC, 50 mA when all points ON, (the max. rating is 100 mA per point) sink mode output (NPN) Signal connection method: Connector (FCN360 series)</p>	
Module power supply	<p>24 VDC (20.4 V to 28.8 V) Rated current: 0.5 A Inrush current: 1 A</p>	
Weight	590 g	

MECHATROLINK-II, counter module (PL2900)

Items	Specifications	Appearance
Model	JEPMC-PL2900	
Number of input channels	2	
Functions	Pulse counter, notch output, registration input	
Pulse input method	Sign (1/2 multipliers), A/B (1/2/4 multipliers), UP/DOWN (1/2 multipliers)	
Max. counter speed	1200 kpps (4 multipliers)	
Pulse input voltage	3/5/12/24 VDC	
External power supply	For input signal: 24 VDC, For dividing load: 24 VDC, For module: 24 VDC (20.4 V to 26.4 V), 120 mA or less	
Weight	300 g	

MECHATROLINK-II, pulse output module (PL2910)

Items	Specifications	Appearance
Model	JEPMC-PL2910	
Number of output channels	2	
Functions	Pulse positioning, JOG run, zero-point return	
Pulse output method	CW, CCW pulse, sign	
Max. output speed	500kpps	
Pulse output voltage	5VDC	
Pulse interface circuit	Open collector output 5VDC, 10mA/circuit	
External control signal	Digital input: 8 points/module, 5 VDC x 4 points, 24 VDC x 4 points Digital output: 6 points/module, 5 VDC x 4 points, 24 VDC x 2 points	
Weight	300 g	

MECHATROLINK-II, analog input module (AN2900)

Items	Specifications	Appearance
Model	JEPMC-AN2900	
Number of input channels	4	
Input voltage range	-10 V to +10 V	
Input impedance	1 MΩ min.	
Data format	Binary, -32000 to +32000	
Input delay time	4 ms max.	
Error	± 0.5% F.S. (at 25 °C), ± 1.0% F.S. (at 0 °C to 60 °C)	
External power supply	24 VDC (20.4 VDC to 26.4 VDC), 120 mA max.	
Weight	300 g	

MECHATROLINK-II, analog output module (AN2910)

Items	Specifications	Appearance
Model	JEPMC-AN2910	
Number of output channels	2	
Output voltage range	- 1.0 V to + 1.0 V	
Max. allowable load current	± 5 mA (2 kΩ)	
Data format	Binary, -32000 to +32000	
Output delay time	1 m s	
Error	± 0.2% F.S. (at 25 °C), ± 0.5% F.S. (at 0 °C to 60 °C)	
External power supply	24 VDC (20.4 VDC to 26.4 VDC), 120 mA max.	
Weight	300 g	

MECHATROLINK-II, repeater

Items	Specifications	Appearance
Model	JEPMC-REP2000	
Communication type	MECHATROLINK-II	
Cable length	Between controller and repeater: 50 m., after repeater: 50 m	
Max. connected stations	Total stations on both sides of repeater: 30 (limited to the max. number of connectable stations of the controller (e.g., 21 stations for the MP2300	
Restrictions	Between controller and repeater - Total cable length ≤ 30 m: 15 stations max. including I/O and servo, etc. - 30 m < total cable length After ≤ 50 m: 14 stations max. including I/O and servo, etc. repeater: - Total cable length ≤ 30 m: 16 stations max. including I/O and servo, etc. - 30 m < total cable length ≤ 50 m: 15 stations max. including I/O and servo, etc.	
Power supply	24 VDC, 100 mA	
Weight	340 g	
Dimensions (mm)	30x160x77 (HxVxD)	

MECHATROLINK-II, servo drive interface unit

Item	Details		
Type	JUSP-NS115		
Applicable servo drive	SGDH-@@@E models (version 38 or later)		
Installation method	Mounted on the SGDh servo drive side: CN10.		
Basic specifications	Power supply method	Supplied from the servo drive control power supply.	
	Power consumption	2 W	
MECHATROLINK - II communications	Baud rate/transmission cycle	10 Mbps / 1 ms or more. MECHATROLINK-II communications	
Command format	Operation specification	Positioning using MECHATROLINK-I/II communications.	
	Reference input	MECHATROLINK-I/II communications Commands: position, speed, torque, parameter read/write, monitor	
Position control functions	Acceleration/deceleration method	2/1/0# first/second-step, asymmetric, exponential, S-curve	
	Fully closed control	Position control with fully closed feedback is possible.	
Fully closed system specifications	Encoder pulse output in the servo drive	5 V differential line-driver output (complies with EIA Standard RS-422A)	
	Fully closed encoder pulse signal	A quad B line-driver	
	Maximum receivable frequency for servo drive	1 Mpps	
	Power supply for fully closed encoder	To be prepared by customer.	
Input signals in the servo drive	Signal allocation changes possible	Forward/reverse run prohibited, zero point return deceleration LS External latch signals 1, 2, 3 Forward/reverse torque control	
Internal functions	Position data latch function	Position data latching is possible using phase C, and external signals 1, 2, 3	
	Protection	Parameters damage, parameter setting errors, communications errors, WDT errors, fully closed encoder detecting disconnection	
	LED indicators	A: alarm, R: MECHATROLINK-I/II communicating	

MECHATROLINK-II, frequency inverter interface units

Item	Details	
Type	SI-T/V7	SI-T
Applicable inverter	CIMR-V7 / 3G3-MV (firmware 5740 or newer)	CIMR-G7 / CIMR-F7 (firmware 656x/for G7 / 4011 or newer for F7)
	Contact your OMRON sales office for information about firmware compatibility	
Installation method	Mounted on the inverter	
Power supply	Supplied from the inverter	
MECHATROLINK-II communications	10 MHz, 0.5 ms to 8 ms for MECHATROLINK-II	
Operation	Read and write registers, read monitors, inverter operation, speed reference, torque reference (G7/F7 only).	
Inputs and outputs	The inputs and outputs in the inverter can be read and set by the MLII master	
Connectors	ML-II bus connector. DPRAM connector for the inverter	
Switches	Rotary switch for ML-II address (low byte)	
	Dip switch for: ML-II address (high bit). ML-II/ML-I selection. 17 byte/32 byte data length selection.	

Dimensions

MP2300 basic module

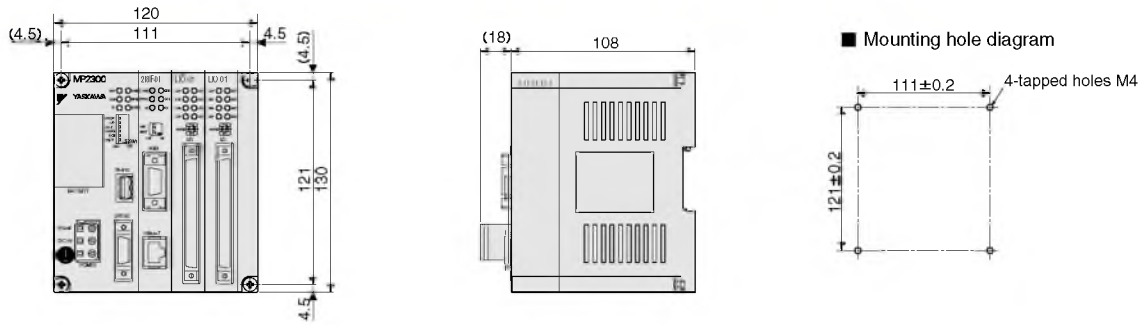

IO2310 I/O module

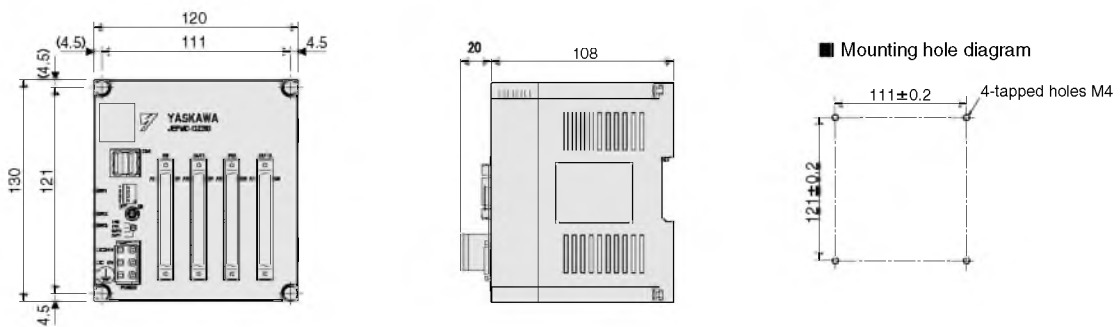

I/O modules PL2900, PL2910, AN2900, AN2910

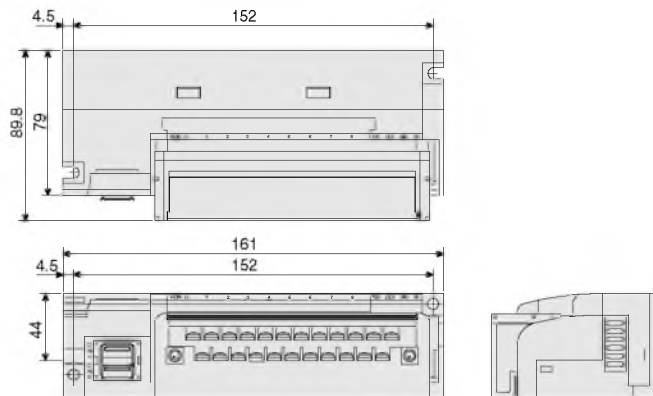

MECHATROLINK-II servo drive interface unit

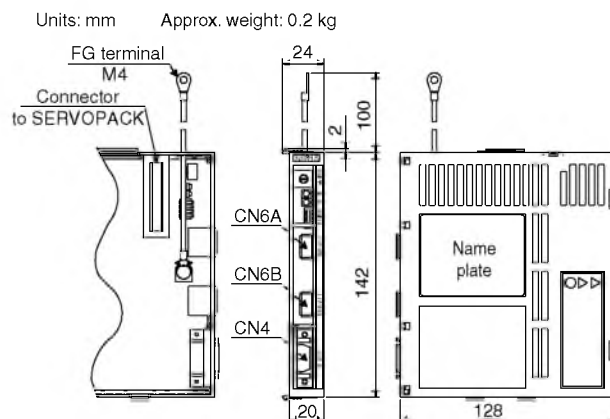

Ordering information

MP2300 - motion controller main unit

Name	Model name	Model
MP2300 basic module (CPU module included), 1 channel for MECHATROLINK-II, I/O	MP2300	JEPMC-MP2300

MP2300 - motion control modules

Name	Model name	Model
Analogue reference motion control module (2 axes)	SVA-01	JAPMC-MC2300
1 additional MECHATROLINK-II communication channel	SVB-01	JAPMC-MC2310

MP2300 - communication modules

Name	Model name	Model
General-purpose serial communication module (RS-232C / RS422 communication)	217IF-01	JAPMC-CM2310
Ethernet communication module (RS-232C / ethernet communication)	218IF-01	JAPMC-CM2300
DeviceNet communication module (RS-232C / DeviceNet communication)	260IF-01	JAPMC-CM2320
PROFIBUS communication module (RS-232C / PROFIBUS communication)	261IF-01	JAPMC-CM2330

MP2300 - I/O modules

Name	Model name	Model
16-point input, 16-point output (sink mode output / NPN), and 1-point pulse input	LIO-01	JAPMC-IO2300
16-point input, 16-point output (source mode output / PNP), and 1-point pulse input	LIO-02	JAPMC-IO2301
32-point input and 32-point output	LIO-04	JAPMC-IO2303

MECHATROLINK-II - related devices

Name	Remarks	Model
Distributed I/O modules	64-point input and 64-point output	JEPMC-IO2310
	Reversible counter: 2 channels	JEPMC-PL2900
	Pulse output: 2 channels	JEPMC-PL2910
	Analog input: -10 V to +10 V, 4 channels	JEPMC-AN2900
	Analog output: -10 V to +10 V, 2 channels	JEPMC-AN2910
MECHATROLINK-II cables	0.5 meter	JEPMC-W6003-A5
	1 meter	JEPMC-W6003-01
	3 meters	JEPMC-W6003-03
	5 meters	JEPMC-W6003-05
	10 meters	JEPMC-W6003-10
	20 meters	JEPMC-W6003-20
	30 meters	JEPMC-W6003-30
MECHATROLINK-II terminator	Terminating resistor	JEPMC-W6022
MECHATROLINK-II interface unit	For Sigma-II series servo drives. (Firmware version 38 or later)	JJSP-NS115
	For Varispeed V7 inverter (for inverter version support contact your OMRON sales office)	SI-T/V7
	For Varispeed F7, G7 inverter (for inverter version support contact your OMRON sales office)	SI-T
MECHATROLINK-II repeater	MECHATROLINK-II repeater	JEPMC-REP2000

I/O cables

	Remarks	Length m	Model
I/O cable for LIO-01, 02	With connector on the LIO-01, -02 side	0.5	JEPMC-W2061-A5
		1.0	JEPMC-W2061-01
		3.0	JEPMC-W2061-03
I/O cable for LIO-04	With connector on the LIO-04 side	0.5	JEPMC-W6060-05
		1.0	JEPMC-W6060-10
		3.0	JEPMC-W6060-30
I/O cable for MP2300	With connector on the MP2300 side	0.5	JEPMC-W2060-A5
		1.0	JEPMC-W2060-01
		3.0	JEPMC-W2060-03
I/O cable for IO2310	With connector on the IO2310 side	0.5	JEPMC-W5410-05
		1.0	JEPMC-W5410-10
		3.0	JEPMC-W5410-30

Accessories

Name	Model
Battery ER3V 3.6V	JZSP-BA01
Empty slot cover	JEPMC-OP2300
Brackets for DIN rail	JEPMC-OP300

Computer software

Specifications	Model
Programming software to support from system design to maintenance. Intuitive ladder programming and editing functions. CAM data generation Windows-based (Windows 95/98/NT4.0/2000/XP)	CPMC-MPE720

Servo system

Note: Refer to servo systems section for detailed information

Frequency inverters

Note: Refer to frequency inverters section for detailed information

ALL DIMENSIONS SHOWN ARE IN MILLIMETERS.

To convert millimeters into inches, multiply by 0.03937. To convert grams into ounces, multiply by

0.03527.

Cat. No. I34E-EN-01 In the interest of product improvement, specifications are subject to change without notice.

По вопросам продаж и поддержки обращайтесь:

Архангельск (8182)63-90-72
Астана +7(7172)727-132
Белгород (4722)40-23-64
Брянск (4832)59-03-52
Владивосток (423)249-28-31
Волгоград (844)278-03-48
Вологда (8172)26-41-59
Воронеж (473)204-51-73
Екатеринбург (343)384-55-89
Иваново (4932)77-34-06
Ижевск (3412)26-03-58
Казань (843)206-01-48

Калининград (4012)72-03-81
Калуга (4842)92-23-67
Кемерово (3842)65-04-62
Киров (8332)68-02-04
Краснодар (861)203-40-90
Красноярск (391)204-63-61
Курск (4712)77-13-04
Липецк (4742)52-20-81
Магнитогорск (3519)55-03-13
Москва (495)268-04-70
Мурманск (8152)59-64-93
Набережные Челны (8552)20-53-41

Нижегород (831)429-08-12
Новокузнецк (3843)20-46-81
Новосибирск (383)227-86-73
Орел (4862)44-53-42
Оренбург (3532)37-68-04
Пенза (8412)22-31-16
Пермь (342)205-81-47
Ростов-на-Дону (863)308-18-15
Рязань (4912)46-61-64
Самара (846)206-03-16
Санкт-Петербург (812)309-46-40
Саратов (845)249-38-78

Смоленск (4812)29-41-54
Сочи (862)225-72-31
Ставрополь (8652)20-65-13
Тверь (4822)63-31-35
Томск (3822)98-41-53
Тула (4872)74-02-29
Тюмень (3452)66-21-18
Ульяновск (8422)24-23-59
Уфа (347)229-48-12
Челябинск (351)202-03-61
Череповец (8202)49-02-64
Ярославль (4852)69-52-93