

# Мощные контроллеры на базе ПК серии MP2100

## ТЕХНИЧЕСКИЕ ХАРАКТЕРИСТИКИ

**По вопросам продаж и поддержки обращайтесь:**

Архангельск (8182)63-90-72  
Астана +7(7172)727-132  
Белгород (4722)40-23-64  
Брянск (4832)59-03-52  
Владивосток (423)249-28-31  
Волгоград (844)278-03-48  
Вологда (8172)26-41-59  
Воронеж (473)204-51-73  
Екатеринбург (343)384-55-89  
Иваново (4932)77-34-06  
Ижевск (3412)26-03-58  
Казань (843)206-01-48

Калининград (4012)72-03-81  
Калуга (4842)92-23-67  
Кемерово (3842)65-04-62  
Киров (8332)68-02-04  
Краснодар (861)203-40-90  
Красноярск (391)204-63-61  
Курск (4712)77-13-04  
Липецк (4742)52-20-81  
Магнитогорск (3519)55-03-13  
Москва (495)268-04-70  
Мурманск (8152)59-64-93  
Набережные Челны (8552)20-53-41

Нижний Новгород (831)429-08-12  
Новокузнецк (3843)20-46-81  
Новосибирск (383)227-86-73  
Орел (4862)44-53-42  
Оренбург (3532)37-68-04  
Пенза (8412)22-31-16  
Пермь (342)205-81-47  
Ростов-на-Дону (863)308-18-15  
Рязань (4912)46-61-64  
Самара (846)206-03-16  
Санкт-Петербург (812)309-46-40  
Саратов (845)249-38-78

Смоленск (4812)29-41-54  
Сочи (862)225-72-31  
Ставрополь (8652)20-65-13  
Тверь (4822)63-31-35  
Томск (3822)98-41-53  
Тула (4872)74-02-29  
Тюмень (3452)66-21-18  
Ульяновск (8422)24-23-59  
Уфа (347)229-48-12  
Челябинск (351)202-03-61  
Череповец (8202)49-02-64  
Ярославль (4852)69-52-93

MP2100 - MECHATROLINK-II

# PC motion controller

**PC based solution for advanced motion control**

- Up to 32 axes controlled with minimum wiring
- Motion APIs are available for customised control applications. Motion commands can be input from either the PC application or the MP2100 program
- Self configuration of nodes for an easy setup
- Supports position, speed and torque control
- Electronic CAM profiles and axes synchronization
- The high-speed bus MECHATROLINK-II is specially designed for motion control
- Support for I/Os locally and over the network
- Access to the complete system from one point

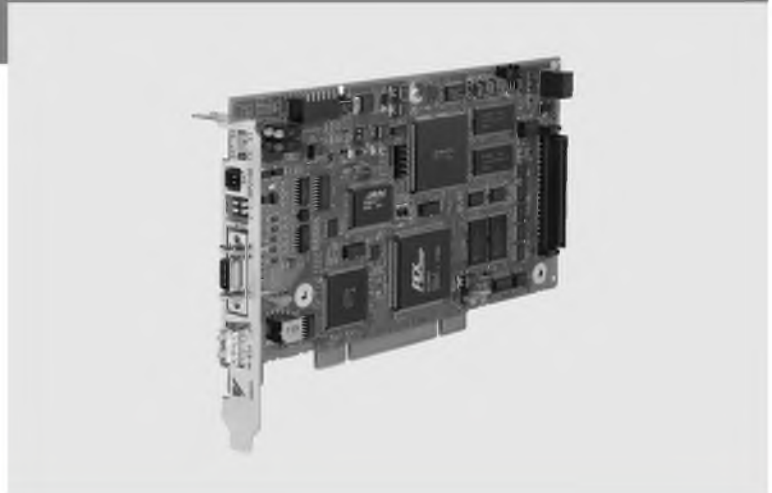

**System configuration**

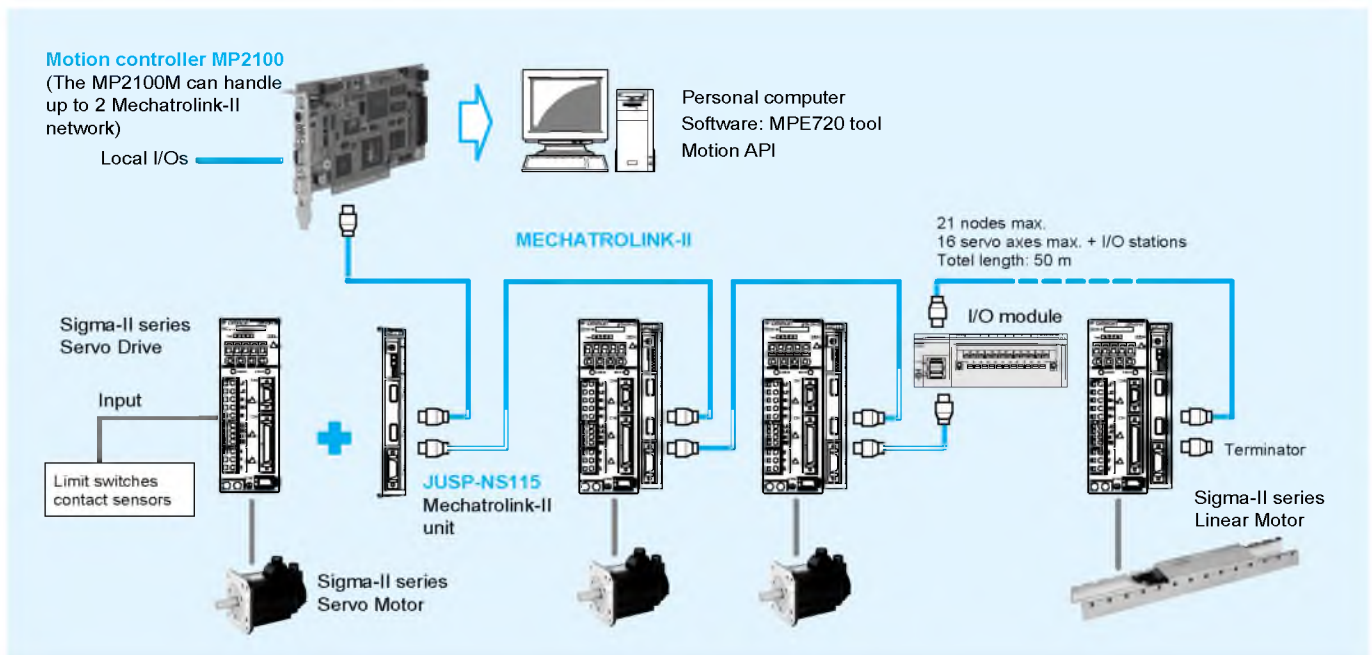

Specifications

General specifications

Hardware specifications

Items	Specifications	
Environmental conditions	Ambient operating temperature	0 to 55 °C
	Ambient storage temperature	-25 to 85 °C
	Ambient operating humidity	30% to 95% (with no condensation)
	Ambient storage humidity	5% to 95% (with no condensation)
	Pollution level	Pollution level 1 (conforming to JIS B 3501)
	Corrosive gas	There must be no combustible or corrosive gas.
Mechanical operating conditions	Operating altitude	2,000 m above sea level or lower
	Vibration resistance	Conforming to JIS B 3502: 10 to 57 Hz with single-amplitude of 0.075 mm 57 to 150 Hz with fixed acceleration of 1 G 10 sweeps each in X, Y, and Z directions (sweep time: 1 octave/decade)
	Shock resistance	Conforming to JIS B 3502: Peak acceleration of 147 m/s <sup>2</sup> (15 G) twice for 11 ms each in the X, Y, and Z directions
Electrical operating conditions	Noise resistance	Conforming to EN 61000-6-2, EN 55011 (Group 1, Class A)
Installation requirements	Ground	Ground to 100 Ω max.
	Cooling method	Natural cooling

Sequential function specifications

Items	Specifications	
Control method	Sequence: High-speed and low-speed scan methods	
Programming language	Ladder diagram:	Relay circuit
	Text-type language:	Numeric operations, logic operations,
Scanning	Two scan levels:	High-speed scan and low-speed scan
	High-speed scan time setting:	1 to 32 ms (Integral multiple of MECHATROLINK communication cycle)
	Low-speed scan time setting:	2 to 300 ms (Integral multiple of MECHATROLINK communication cycle)
User drawings, functions and motion programs	Startup drawings (DWG.A):	64 drawings max. up to three hierarchical drawing levels
	Interrupt processing drawings (DWG.I):	64 drawings max. up to three hierarchical drawing levels
	High-speed scan process drawings (DWG.H):	200 drawings max. up to three hierarchical drawing levels
	Low-speed scan process drawings (DWG.L):	Number of steps: 500 drawings max. up to three hierarchical drawing levels
	User functions:	Up to 1,000 steps per drawing
	Motion programs:	Up to 500 functions
Data memory	Revision history of drawings and motion programs	Up to 256
	Security function for drawings and motion programs	
	64-bit data (M) registers:	64 Kwords
	System (S) registers: Drawing	8 Kwords
	local (D) registers: Drawing	Up to 16 Kwords per drawing
	constant (#) registers: Input (I) registers:	Up to 16 Kwords per drawing
Output (O) registers: Constant	5 Kwords (including internal input registers) 5	
(C) registers:	Kwords (including internal output registers) 16 Kwords	
Trace memory	Data trace: 128 Kwords (32 Kwords / 4 groups), 16 points defined	
Memory backup	Program memory:	Flash memory: 8 MBytes (User area: 5.5 MBytes) definition files, ladder programs, motion programs, etc.
	Data memory:	Battery backup: 256 Kbytes, M registers, S registers, alarm history, trace data
Data types	Bit (relay):	ON/OFF
	Integer:	-32768 to +32767
	Double-length integer:	-2147483648 to +2147483647
	Real number:	± (1.175E-38 to 3.402E+38)
Register designation method	Register number:	Direct designation of register number
	Symbolic designation:	Up to 8 alphanumeric characters (up to 200 symbols per drawing) With automatic number or symbol assignment

Motion control function specifications.

Item	Specifications		
Interface	MECHATROLINK-I, MECHATROLINK-II		
Number of controlled axes/module	Up to 16 axes		
Control specifications	PTP control	Linear, rotary, and infinite-length	
	Interpolation	Up to 16 linear axes, 2 circular axes, and 3 helical axes	
	Speed reference output	Yes	
	Torque reference output	Yes	
	Phase control	Yes	
	Position control	Positioning	Yes
		External positioning	Yes
		Zero point return	Yes
		Interpolation	Yes
		Interpolation with position detection function	Yes
JOG operation		Yes	
STEP operation		Yes	
Parameter changes during motion command execution	Yes		
Reference unit	mm, inch, deg, or pulse		
Reference unit minimum setting	1, 0.1, 0.01, 0.001, 0.0001, 0.00001		
Maximum programmable value	-2147483648 to +2147483647 (signed 32-bit value)		
Speed reference unit	Reference unit/s designation: mm/s, inch/s, deg/s, pulse/s Reference unit/min. designation: mm/min, inch/min, deg/min, pulse/min Percentage designation: Percentage of rated speed		
Acceleration/deceleration type	Linear, asymmetric, S-curve, exponent		
Acceleration/deceleration reference unit	Reference unit/s <sup>2</sup> designation: mm/s <sup>2</sup> , inch/s <sup>2</sup> , deg/s <sup>2</sup> , pulse/s <sup>2</sup> Acceleration/deceleration time constant: Time from 0 to rated speed		
Override function	Positioning: 0.01% to 327.67% by axis		
Coordinate system	Rectangular coordinates		
Zero point return	DEC1+ phase-C pulse	Yes	
	ZERO signal	Yes	
	DEC1+ ZERO signal	Yes	
	Phase-C pulse	Yes	
	Only phase-C pulse	Yes	
	POT and phase-C pulse	Yes	
	POT	Yes	
	Home limit switch and phase-C pulse	Yes	
	HOME	Yes	
	NOT and phase-C pulse	Yes	
	NOT	Yes	
INPUT and phase-C pulse	Yes		
INPUT	Yes		
Applicable servo drives	SGDH-@@@E-OY + NS115		
Applicable frequency inverters	Varispeed V7, F7, G7 with MECHATROLINK-II Interface (for inverter's version supported contact your OMRON sales office)		
Encoders	Omron incremental encoder Yaskawa absolute encoder		

MP2100, MP2100M boards

Items	Specifications	Appearance	
Model	JAPMC-MC2100, JAPMC-MC2140		
Power supply	Input supply voltage: 5 VDC±5%		
Dimensions	106.68x174.63 mm half the size of a standard PCI		
Motion network	MECHATROLINK-II: One channel with MP2100, two channels with MP2100M Twenty-one stations, including servo drives, inverters and I/O equipment, can be connected. (16 axes for servo drives and inverters) Transmission speed: 10Mbps (MECHATROLINK-II) Transmission distance: See "MECHATROLINK-II repeater"		
I/O signals	Digital input: 5 points (one point can be used for interrupts), 24 VDC, 4 mA, and source mode or sink mode input Digital output: 4 points, 24 VDC, 100 mA, open collector, and sink mode		
Electrical operating conditions	Noise resistance		Electromagnetic noise (FT noise): 1 kV or more for 1 min. Static noise (contact discharging method): 6 kV or more for 10 μs Vibration noise: Not specified
	Mechanical operating conditions		Vibration resistance: Not specified Shock resistance: Not specified
Installation requirements	Ground		Follows the personal computer's requirements
Environmental conditions			Same as the general specifications

**Host computer specifications**

Items	Specifications	
Hardware	Model	PC/AT compatible
	CPU	Pentium 200 MHz or more (Pentium 400 MHz or more recommended)
	Memory capacity	64 MB or more
	Hard disk drive capacity	Free space 500 MB or more
	Display resolution	800x600 or more (1024x768 recommended)
	Expansion slot <sup>1</sup>	Half the size of a standard PCI slot
	Interrupts <sup>1</sup>	First-level use (IRQ sharing is possible)
	I/O memory <sup>1</sup>	32 kB shared memory used
Software	OS	Windows NT 4.0 Workstation SP5 or later Windows 2000 Professional SP1 or later Windows XP
	Web browser	Microsoft IE 5.5 SP2 or later
	Language	Microsoft Visual C/C++ 6.0 SP5 or later

1. These specifications are applicable if using one MP2100s board. If using two or more boards in the same host personal computer, expansion slots, inter-rupts and I/O memory resources needs to be increased per each board.

**MECHATROLINK-II, 64 point I/O module (IO2310)**

Items	Specifications	Appearance
Model	JEPMC-IO2310	
I/O signals	Input: 64 points, 24 VDC, 5 mA, sink/source mode input Output: 64 points, 24 VDC, 50 mA when all points ON, (The max. rating is 100 mA per point) sink mode output (NPN) Signal connection method: Connector (FCN360 series)	
Module power supply	24 VDC (20.4 V to 28.8 V) Rated current: 0.5 A Inrush current: 1 A	
Weight	590 g	

**MECHATROLINK-II, counter module (PL2900)**

Items	Specifications	Appearance
Model	JEPMC-PL2900	
Number of input channels	2	
Functions	Pulse counter, notch output, registration input	
Pulse input method	Sign (1/2 multipliers), A/B (1/2/4 multipliers), UP/DOWN (1/2 multipliers)	
Max. counter speed	1200 kpps (4 multipliers)	
Pulse input voltage	3/5/12/24 VDC	
External power supply	For input signal: 24 VDC, for dividing load: 24 VDC, for module: 24 VDC (20.4 V to 26.4 V), 120 mA or less	
Weight	300 g	

**MECHATROLINK-II, pulse output module (PL2910)**

Items	Specifications	Appearance
Model	JEPMC-PL2910	
Number of output channels	2	
Functions	Pulse positioning, JOG run, zero-point return	
Pulse output method	CW, CCW pulse, sign	
Max. output speed	500 kpps	
Pulse output voltage	5 V D C	
Pulse interface circuit	Open collector output 5 VDC, 10 mA/circuit	
External control signal	Digital input: 8 points/module, 5 VDC x 4 points, 24 VDC x 4 points Digital output: 6 points/module, 5 VDC x 4 points, 24 VDC x 2 points	
Weight	300 g	

**MECHATROLINK-II, analog input module (AN2900)**

Items	Specifications	Appearance
Model	JEPMC-AN2900	
Number of input channels	4	
Input voltage range	-10 V to +10 V	
Input impedance	1 M Ω min.	
Data format	Binary, -32000 to +32000	
Input delay time	4 m s m a x .	
Error	+ 0.5% F.S. (at 25 °C), + 1.0% F.S. (at 0 °C to 60 °C)	
External power supply	24 VDC (20.4 VDC to 26.4 VDC), 120 mA max.	
Weight	300 g	

**MECHATROLINK-II, analog output module (AN2910)**

Items	Specifications	Appearance
Model	JEPMC-AN2910	
Number of output channels	2	
Output voltage range	- 1.0 V to + 1.0 V	
Max. allowable load current	± 5 mA (2 kΩ)	
Data format	Binary, -32000 to +32000	
Output delay time	1 m s	
Error	± 0.2% F.S. (at 25 °C), ± 0.5% F.S. (at 0 °C to 60 °C)	
External power supply	24 VDC (20.4 VDC to 26.4 VDC), 120 mA max.	
Weight	300 g	

**MECHATROLINK-II repeater**

Items	Specifications	Appearance
Model	JEPMC-REP2000	
Communication type	MECHATROLINK-II	
Cable length	Between controller and repeater: 50 m, after repeater: 50 m	
Max. connected stations	Total stations on both sides of repeater: 30 (limited to the max. number of connectable stations of the controller (e.g., 21 stations for the MP2300)	
Restrictions	Between controller and repeater - Total cable length ≤ 30 m: 15 stations max. including I/O and servo, etc. - 30 m < total cable length ≤ 50 m: 14 stations max. including I/O and servo, etc. After repeater: - Total cable length ≤ 30 m: 16 stations max. including I/O and servo, etc. - 30 m < total cable length ≤ 50 m: 15 stations max. including I/O and servo, etc.	
Power supply	24 VDC, 100 mA	
Weight	340 g	
Dimensions (mm)	30x160x77 (HxVxD)	

**MECHATROLINK-II servo drive interface unit**

Item	Details		
Type	JUSP-NS115		
Applicable servo drive	SGDH-@@@E models (version 38 or later)		
Installation method	Mounted on the SGDh servo drive side: CN10.		
Basic specifications	Power supply method	Supplied from the servo drive control power supply.	
	Power consumption	2 W	
MECHATROLINK-II communications	Baud rate/transmission cycle	10 Mbps / 1 ms or more. MECHATROLINK-II communications	
Command format	Operation specification	Positioning using MECHATROLINK-I/II communications.	
	Reference input	MECHATROLINK-I/II communications Commands: position, speed, torque, parameter read/write, monitor	
Position control functions	Acceleration/deceleration method	0/1/2/3 first/second-step, asymmetric, exponential, S-curve	
	Fully closed control	Position control with fully closed feedback is possible.	
Fully closed system specifications	Encoder pulse output in the servo drive	5 V differential line-driver output (complies with EIA Standard RS-422A)	
	Fully closed encoder pulse signal	A quad B line-driver	
	Maximum receivable frequency for servo drive	1 Mpps	
	Power supply for fully closed encoder	To be prepared by customer.	
Input signals in the servo drive	Signal allocation changes possible	Forward/reverse run prohibited, zero point return deceleration LS External latch signals 1, 2, 3 Forward/reverse torque control	
Internal functions	Position data latch function	Position data latching is possible using phase C, and external signals 1, 2, 3	
	Protection	Parameters damage, parameter setting errors, communications errors, WDT errors, fully closed encoder detecting disconnection	
	LED indicators	A: Alarm, R: MECHATROLINK-I/II communicating	

**MECHATROLINK-II, frequency inverter interface units**

Item	Details	
Type	SI-T/V7	SI-T
Applicable inverter	CIMR-V7 / 3G3-MV (firmware 5740 or newer)	CIMR-G7 / CIMR-F7 (firmware 656x/for G7 / 4011 or newer for F7)
	Contact your OMRON sales office for information about firmware compatibility	
Installation method	Mounted on the inverter	
Power supply	Supplied from the inverter	
MECHATROLINK-II communications	10 MHz, 0.5 ms to 8 ms for MECHATROLINK-II	
Operation	Read and write registers, read monitors, inverter operation, speed reference, torque reference (G7/F7 only).	
Inputs and outputs	The inputs and outputs in the inverter can be read and set by the MLII master	
Connectors	ML-II bus connector. DPRAM connector for the inverter	
Switches	Rotary switch for ML-II address (low byte) Dip switch for: ML-II address (high bit). ML-II/ML-I selection. 17 byte/32 byte data length selection.	

Dimensions

MP2100, MP2100M boards

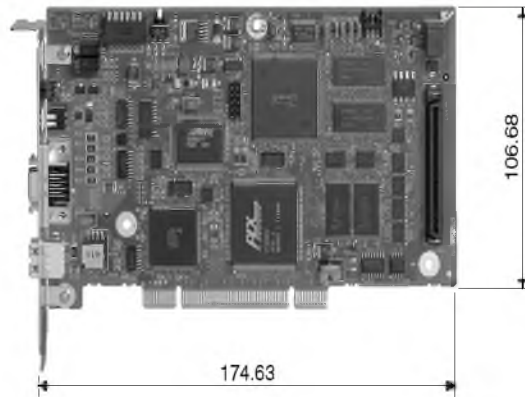

IO2310 I/O module

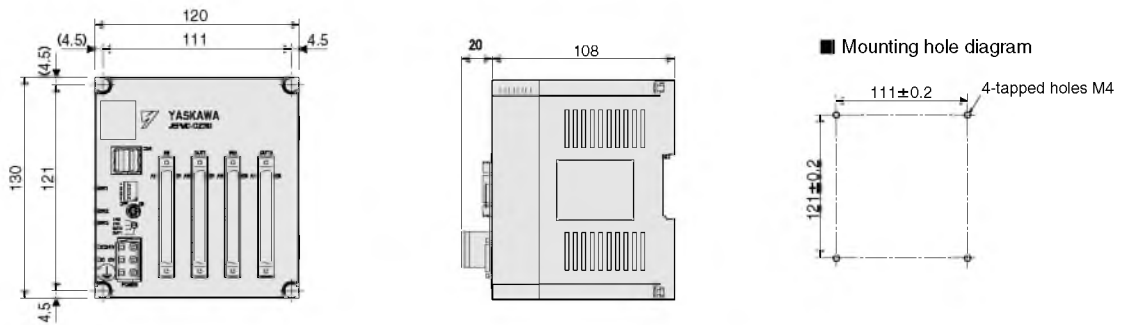

I/O modules PL2900, PL2910, AN2900, AN2910

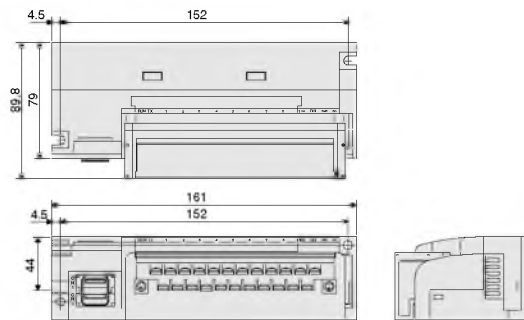

MECHATROLINK-II servo drive interface unit

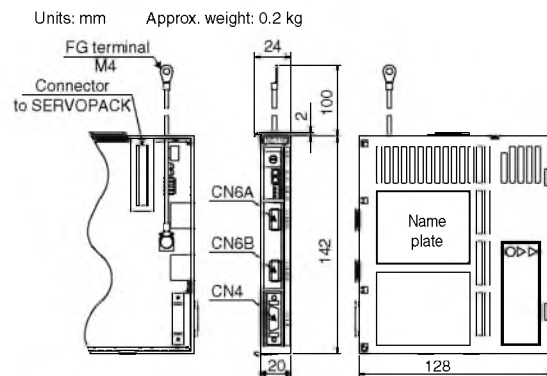

## Ordering information

### MP2100 - motion controller main units

Name	Model name	Model
MP2100 board, 1 channel for MECHATROLINK-II communication, 5-point input and 4-point output	MP2100	JAPMC-MC2100
MP2100M board, 2 channels for MECHATROLINK-II communication, 5-point input and 4-point output	MP2100M	JAPMC-MC2140

### MECHATROLINK-II - related devices

Name	Remarks	Model
Distributed I/O modules	64-point input and 64-point output	JEPMC-IO2310
	Reversible counter: 2 channels	JEPMC-PL2900
	Pulse output: 2 channels	JEPMC-PL2910
	Analog input: -10 V to +10 V, 4 channels	JEPMC-AN2900
	Analog output: -10 V to +10 V, 2 channels	JEPMC-AN2910
MECHATROLINK-II cables	0.5 meter	JEPMC-W6003-A5
	1 meter	JEPMC-W6003-01
	3 meters	JEPMC-W6003-03
	5 meters	JEPMC-W6003-05
	10 meters	JEPMC-W6003-10
	20 meters	JEPMC-W6003-20
30 meters	JEPMC-W6003-30	
MECHATROLINK-II terminator	Terminating resistor	JEPMC-W6022
MECHATROLINK-II interface unit	For Sigma-II series servo drives. (Firmware version 38 or later)	JUSP-NS115
	For Varispeed V7 inverter (for inverter version support contact your OMRON sales office)	SI-TV7
	For Varispeed F7, G7 inverter (for inverter version support contact your OMRON sales office)	SI-T
MECHATROLINK-II repeater	MECHATROLINK-II repeater	JEPMC-REP2000

### I/O cables

Name	Remarks	Length m	Model
I/O cable for MP2100	With connector on the MP2100 side	0.5	JEPMC-W2062-A5
		1.0	JEPMC-W2062-01
		3.0	JEPMC-W2062-03
I/O cable for IO2310	With connector on the IO2310 side	0.5	JEPMC-W5410-05
		1.0	JEPMC-W5410-10
		3.0	JEPMC-W5410-30

### Accessories

Name	Model
Battery ER3V 3.6V	JZSP-BA01
Extended cable for battery with connectors on both sides	JEPMC-W2090-01
Brackets for DIN rail	JEPMC-OP300

### Computer software

Specifications	Model
Programming software to support from system design to maintenance. Intuitive ladder programming and editing functions. CAM data generation Windows-based (Windows 95/98/NT4.0/2000/XP)	CPMC-MPE720
Motion API. Header file, library, DLL, driver, and manual	CPMC-MPA70

### Servo system

**Note:** Refer to servo systems section for detailed information

### Frequency inverters

**Note:** Refer to frequency inverters section for detailed information



**По вопросам продаж и поддержки обращайтесь:**

Архангельск (8182)63-90-72  
Астана +7(7172)727-132  
Белгород (4722)40-23-64  
Брянск (4832)59-03-52  
Владивосток (423)249-28-31  
Волгоград (844)278-03-48  
Вологда (8172)26-41-59  
Воронеж (473)204-51-73  
Екатеринбург (343)384-55-89  
Иваново (4932)77-34-06  
Ижевск (3412)26-03-58  
Казань (843)206-01-48

Калининград (4012)72-03-81  
Калуга (4842)92-23-67  
Кемерово (3842)65-04-62  
Киров (8332)68-02-04  
Краснодар (861)203-40-90  
Красноярск (391)204-63-61  
Курск (4712)77-13-04  
Липецк (4742)52-20-81  
Магнитогорск (3519)55-03-13  
Москва (495)268-04-70  
Мурманск (8152)59-64-93  
Набережные Челны (8552)20-53-41

Нижний Новгород (831)429-08-12  
Новокузнецк (3843)20-46-81  
Новосибирск (383)227-86-73  
Орел (4862)44-53-42  
Оренбург (3532)37-68-04  
Пенза (8412)22-31-16  
Пермь (342)205-81-47  
Ростов-на-Дону (863)308-18-15  
Рязань (4912)46-61-64  
Самара (846)206-03-16  
Санкт-Петербург (812)309-46-40  
Саратов (845)249-38-78

Смоленск (4812)29-41-54  
Сочи (862)225-72-31  
Ставрополь (8652)20-65-13  
Тверь (4822)63-31-35  
Томск (3822)98-41-53  
Тула (4872)74-02-29  
Тюмень (3452)66-21-18  
Ульяновск (8422)24-23-59  
Уфа (347)229-48-12  
Челябинск (351)202-03-61  
Череповец (8202)49-02-64  
Ярославль (4852)69-52-93