

Power Monitors

KM-N2 / KM-N3

**Multi-circuit Power Monitors for Energy Management
Easily Implement All Types of Power Monitoring
with On-panel and In-panel Installation**



По вопросам продаж и поддержки обращайтесь:

Архангельск (8182)63-90-72
Астана +7(7172)727-132
Астрахань (8512)99-46-04
Барнаул (3852)73-04-60
Белгород (4722)40-23-64
Брянск (4832)59-03-52
Владивосток (423)249-28-31
Волгоград (844)278-03-48
Вологда (8172)26-41-59
Воронеж (473)204-51-73
Екатеринбург (423)384-55-89
Иваново (4932)77-34-06
Ижевск (3412)26-03-58
Иркутск (395) 279-98-46

Казань (843)206-01-48
Калининград (4012)72-03-81
Калуга (4842)92-23-67
Кемерово (3842)65-04-62
Киров (8332)68-02-04
Краснодар (861)203-40-90
Красноярск (391)204-63-61
Курск (4712)77-13-04
Липецк (4742)52-20-81
Магнитогорск (3519)55-03-13
Москва (495)268-04-70
Мурманск (8152)59-64-93
Набережные Челны (8552)20-53-41
Нижний Новгород (831)429-08-12

Новокузнецк (3843)20-46-81
Новосибирск (383)227-86-73
Омск (3812)21-46-40
Орел (4862)44-53-42
Оренбург (3532)37-68-04
Пенза (8412)22-31-16
Пермь (342)205-81-47
Ростов-на-Дону (863)308-18-15
Рязань (4912)46-61-64
Самара (846)206-03-16
Санкт-Петербург (812)309-46-40
Саратов (845)249-38-78
Севастополь (8692)22-31-93
Симферополь (3652)67-13-56

Смоленск (4812)29-41-54
Сочи (862)225-72-31
Ставрополь (8652)20-65-13
Сургут (3462)77-98-35
Тверь (4822)63-31-35
Томск (3822)98-41-53
Тула (4872)74-02-29
Тюмень (3452)66-21-18
Ульяновск (8422)24-23-59
Уфа (347)229-48-12
Хабаровск (4212)92-98-04
Челябинск (351)202-03-61
Череповец (8202)49-02-64
Ярославль (4852)69-52-93

Киргизия (996)312-96-26-47

Казахстан (772)734-952-31

Таджикистан (992)427-82-92-69

New Value For Control Panels

Control Panels: The Heart of Manufacturing Sites.

Evolution in control panels results in large evolution in production facilities.

And if control panel design, control panel manufacturing processes, and human interaction with them are innovated, control panel manufacturing becomes simpler and takes a leap forward.

OMRON will continue to achieve a control panel evolution and process innovation through many undertakings starting with the shared Value Design for Panel *1 concept for the specifications of products used in control panels.



*1 Value Design for Panel

Our shared Value Design for Panel (herein after referred to as "Value Design") concept for the specifications of products used in control panels will create new value to our customer's control panels.

Combining multiple products that share the Value Design concept will further increase the value provided to control panels.

Further Evolution
for
Panels

**New Value
For
Control Panels**

Innovation for
panel building
Process

Simple & Easy
for panel business
People

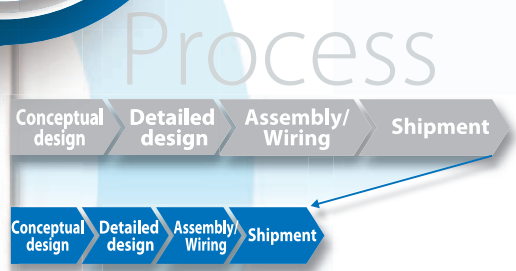

Panels

People



Multi-circuit Power Monitors for Energy Management Easily Implement All Types of Power Monitoring with On-panel and In-panel Installation

The New KM-N2 and KM-N3 Power Monitors

Energy management starts by continuously monitoring power.

The KN-N2 and KN-N3 enable all types of power measurement with easy installation and easy system construction.

You can mount them on or in control panels and distribution boards and take advantage of their compatibility with power supplies around the world.

Multi-circuit measurements

| | |
|---------------------|------------|
| Three-phase 4-wire | 1-circuits |
| Three-phase 3-wire | 2-circuits |
| Single-phase 3-wire | 4-circuits |
| Single-phase 2-wire | 4-circuits |



**Single-phase 100 V to
Three-phase 480 V**



**General-purpose CT
(1 A or 5 A)**





Packed Full of Functions!

**Modbus (RTU)
(RS-485)**



**Four Total Power
Consumption Pulse Outputs**



**IEC Class 0.5S
Accuracy**



**Corresponding
to the Main
International Standards**



Features Common to Both the KM-N2 and KM-N3

Power Monitors for Energy Management That

Easier Application and Greater Work Efficiency for Everyone

System Design Manager

Handle All EMS* Specifications



Energy Manager

No Numeric Value

*EMS: Energy Management System

General-purpose CTs



Corresponding to the Main International Standards



Many Host Communications Methods

PLC Proprietary systems Central monitoring system



RS-485 communications
Modbus(RTU)
CompoWay/F

Total power consumption
pulse outputs

Large Easy-to-read Displays

Actual Size



Multi-address System



| Address Setting | Automatic assignment | Setting | Automatic assignment | Setting |
|---------------------|----------------------|----------------------|----------------------|---------------------|
| 02 | 03 | 04 | 05 | 09 |
| Three-phase, 3-wire | Three-phase, 3-wire | Single-phase, 3-wire | Single-phase, 2-wire | Three-phase, 4-wire |

DIN Rail Installation Type KM-N2



Solve Design, Installation, and Operation Issues

Overlooked 

Installation Manager
Efficient Wiring 



On-panel Installation Type KM-N3



Push-In Plus Terminal Block

The structure of Push-In Plus terminal blocks helps reduce wiring mistakes with easy-to-insert terminals that hold wires firmly (RS-485 communications and pulse output terminals).



Efficient Initial Setting Tool*1

- Easy-to-use setting functions of the communications and measurement conditions
- Save/Load setting by CSV file

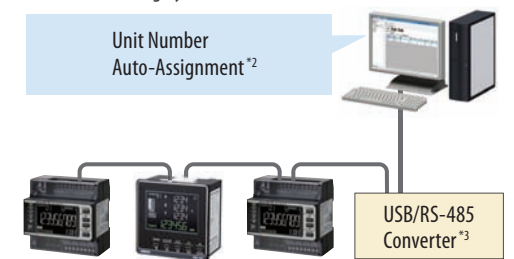

*1. Supported Version of main unit: V2.0.0 or higher for all models.

*2. Except for KM-N2-FLK.

*3. For this software, compatibility of the USB/RS-485 converter has been verified for SI-35USB (LINEEYE Co.,Ltd.). K3SC-10 is not compatible.

Wiring Error Detection

ALARM lamp blinks



! lamp lights up



Power Monitor

KM-N2-FLK

Global Power Monitor for Mounting Inside Control Panels



- Solve design, installation, and operation topics.
- You can measure up to four circuits with one Power Monitor.
- Use general-purpose CTs and handle a variety of worksites.
- Large, easy-to-read white LCD for improved visibility.
- IEC Class 0.5S high-precision measurements (Power Monitor only).



For the most recent information on models that have been certified for safety standards, refer to your OMRON website.

⚠ Refer to Safety Precautions on page 19.

Ordering Information

Power Monitor

| Model | Applicable phase wiring methods | Power supply voltage | Dimensions | Communications |
|-----------|--|--|-------------------------|-------------------------------------|
| KM-N2-FLK | Single-phase, 2-wire: 100 to 277 VAC Single-phase, 3-wire: 100 to 240 VAC (L-N) or 200 to 480 VAC (L-L) Three-phase, 3-wire: 173 to 480 VAC (L-L) Three-phase, 4-wire: 100 to 277 VAC (L-N) or 173 to 480 VAC (L-L) | Same as measured circuits: 100 to 277 VAC (L-N) 173 to 480 VAC (L-L) | 90 x 90 x 65 mm (HxWxD) | RS-485 communications, pulse output |

To use a commercially available current transformer, use a CT with a secondary current rating of 1 A or 5 A, and a rated load of at least 1.0 VA.

Split Type Current Transformer (CT) (CE marking compliant KM-N2/N3 dedicated products *)

| Model | Rated primary current | Rated secondary current |
|--------------|-----------------------|-------------------------|
| KM-NCT-E100A | 100 A | 1 A |
| KM-NCT-E250A | 250 A | |
| KM-NCT-E500A | 500 A | |

* The KM-NCT-E conforms to the standards shown above ONLY when it is used with a power monitor KM-N2-FLK or KM-N3-FLK to which it is attached. Use of the KM-NCT-E without a power monitor does not conform to these standards.

Note: Select a CT cable that does not exceed the rated load of 1 VA.

Specifications

Ratings (Power Monitor)

| Item | Model | KM-N2-FLK |
|---------------------------------|--|--|
| Applicable phase wiring methods | | Single-phase two-wire, single-phase three-wire, three-phase three-wire, and three-phase four-wire |
| Number of measured circuits | | Single-phase two-wire: 4 circuits max., Single-phase three-wire or three-phase three-wire: 2 circuits max., Three-phase four-wire: 1 circuit |
| Power consumption | | 7 VA max. |
| Input | Rated input voltages (power supply voltages) | Single-phase, 2-wire: 100 to 277 VAC Single-phase, 3-wire: 100 to 240 VAC (L-N) or 200 to 480 VAC (L-L) Three-phase, 3-wire: 173 to 480 VAC (L-L) Three-phase, 4-wire: 100 to 277 VAC (L-N) or 173 to 480 VAC (L-L) |
| | Allowable supply voltage range | 85% to 115% of rated power supply voltage |
| | Connectable CTs | General-purpose CT with a rated secondary current of 1 A or 5 A * |
| | Maximum CT secondary current | 6 A |
| | Rated input frequency | 50/60 Hz |
| Ambient operating temperature | | -25 to 55°C (with no condensation or icing) |
| Ambient operating humidity | | 25% to 85% |
| Storage temperature | | -25 to 85°C (with no condensation or icing) |
| Storage humidity | | 25% to 85% |
| Operating altitude | | 2,000 m max. |
| Installation environment | | Overvoltage category II, measurement category II, pollution degree 2 |
| Electromagnetic environment | | Industrial electromagnetic environment (EN/IEC 61326-1 Table 2) |
| Compliant standards | | EN 61010-2-030, EN 61326-1, and UL 61010-1 |

* The KM-series CTs (the KM20-CTF or KM-NCT Series) cannot be used. Use general-purpose CTs with a secondary-side output of 1 A or 5 A.

Split Type Current Transformer (CT) (CE marking compliant KM-N2/N3 dedicated products *)

| Item | KM-NCT-E100A | KM-NCT-E250A | KM-NCT-E500A |
|--|---|---------------|---------------|
| Rated primary current: In | 100 A | 250 A | 500 A |
| Rated secondary current: Is | 1 A | | |
| Rated frequency | 50/60 Hz | | |
| Cable Length | Please refer to <i>Writing to KM-NCT-E□□□A</i> | | |
| Rated load | 1 VA | | |
| Insulation resistance | 100 MΩ min. (at 500 VDC mega) between core and all output terminals | | |
| Dielectric strength voltage | 2300 VAC, 1 minute between core and all output terminals. | | |
| Weight | Approx. 170 g | Approx. 175 g | Approx. 290 g |
| Maximum wire diameter | 24 dia. | 24 dia. | 36 dia. |
| Operating temperature and humidity range | -20 to 55 °C, relative humidity: 85% max. with no condensation | | |
| Storage temperature and humidity range | -30 to 90 °C, relative humidity: 85% max. with no condensation | | |
| Applicable standards * | EN61010-1, EN61010-2-030, EN61326-1 | | |
| Installation environment | Overvoltage category and measurement category: II, Pollution level: 2 | | |

* The KM-NCT-E conforms to the standards shown above ONLY when it is used with a power monitor KM-N2-FLK or KM-N3-FLK to which it is attached. Use of the KM-NCT-E without a power monitor does not conform to these standards.

Wiring to KM-NCT-E□□□A

- For wiring of the output terminal of CT, use AWG18-14 electric wire (with a cross-section of 0.75-2.0 mm²) and Y-shape terminal compatible with the M3 screw.
- The recommended torque for screwing the M3 screws onto the output terminal is 0.3 N·m. Make sure the Y terminal is pushed all the way in and tightened firmly. After fixing the wiring, confirm that the wire is fixed securely.
- The guideline of the maximum wiring length between KM-N2-FLK or KM-N3-FLK and KM-NCT-E is as follows.
The longer the wire length, the larger the measurement error using the KM-NCT-E becomes.
- The limit of the wiring length can also be calculated by the following formula. Calculate the wiring length limit according to the conductor resistivity of the wiring and keep the wiring length below the limit.
- The limits of the wiring length shown below are for reference only. They do not guarantee proper use.

| Wiring diameter | Guideline for wiring length limit |
|---|-----------------------------------|
| 0.75 mm ² (AWG18 equivalent) | 15 m |
| 2.0 mm ² (AWG14 equivalent) | 43 m |

| |
|---|
| $\text{Wiring extension limit value (one-way) (m)} = \frac{0.475}{\text{conductor resistivity } (\Omega/\text{m})}$ |
|---|

Note: Select a CT cable that does not exceed the rated load of 1 VA.

Performance (Power Monitor)

| Item | Model | KM-N2-FLK |
|----------------------------------|--|---|
| Measured items | | Total power consumption (active, regenerative, and reactive), power (active and reactive), current, voltage, power factor, and frequency |
| Measurement specifications | Active power | 0.5% (IEC 62053-22 class 0.5S) * |
| | Reactive power | 2% (IEC 62053-23 class 2) * |
| | Sampling cycle | 80 ms for 50 Hz and 66.7 ms for 60 Hz |
| Insulation resistance | | (1) Between all electrical circuits and the case: 20 MΩ min. (at 500 VDC) (2) Between all power supply and voltage inputs and all communications and pulse output terminals: 20 MΩ max. (at 500 VDC) |
| Dielectric strength | | (1) Between all electrical circuits and the case: 2,200 VAC for 1 min (2) Between all voltage and current inputs and all communications and pulse output terminals: 2,200 VAC for 1 min |
| Vibration resistance | | Single amplitude: 0.1 mm, Acceleration: 15 m/s ² , Frequency: 10 to 150 Hz, 10 sweeps for 8 min each along three axes |
| Shock resistance | | 150 m/s ² , 3 times each in 6 directions (up/down, left/right, forward/backward) |
| Indications and operation method | | LED/LCD indications and operation buttons |
| Weight | | Approx. 350 g (Power Monitor only) |
| Degree of protection | | IP20 |
| Pulse output | Number of outputs | Number of outputs: 4 (photoMOS relay outputs) Used for the total power consumption pulse output. |
| | Output capacity | 50 mA at 40 VDC ON residual voltage: 1.5 V max. (for output current of 50 mA) OFF leakage current: 0.1 mA max. |
| | Output unit | Output unit: 1, 10, 100, 1k, 5k, 10k, 50k, or 100k (wh) Pulse ON time: 500 ms (Cannot be changed.) |
| Communications interface | Communications method | RS-485 (2-wire half-duplex with start-stop synchronization) |
| | Communications protocol | Modbus (RTU): Binary. CompoWay/F: ASCII |
| | Baud rate | 1.2, 2.4, 4.8, 9.6, 19.2, or 38.4 kbps |
| | Data length | Data length: 7 or 8 bits Stop bits: 1 or 2 bits Vertical parity: Even, odd, or none |
| | Maximum transmission distance | 1,200 m |
| | Maximum number of connected Power Monitors | Modbus: 99, CompoWay/F: 31 If you measure more than one circuit with one Power Monitor, the number of circuits is treated as the number of connected Power Monitors. |
| Dimensions (H×W×D) | | 90 × 90 × 65 mm (excluding protrusions) |
| Installation method | | DIN Rail mounting |
| Accessories | | Instruction Manual and Compliance Sheet |

* The error of the CT or VT is not included. IEC 62053 is an international standard for power metering.

KM-N2-FLK

Part Names and Functions

Power Monitor

Front Panel with Terminal Block Covers Removed

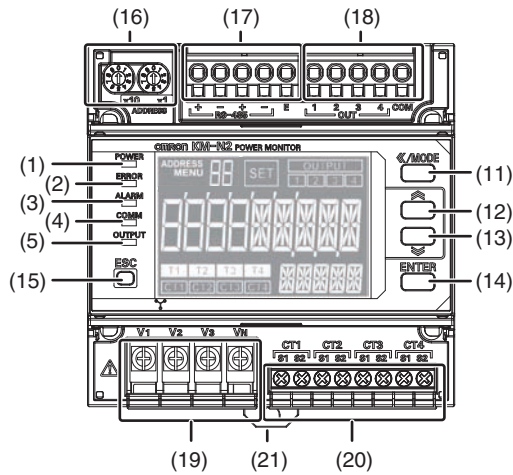

Detailed View of LCD

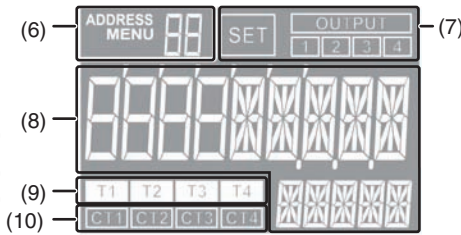

Side View

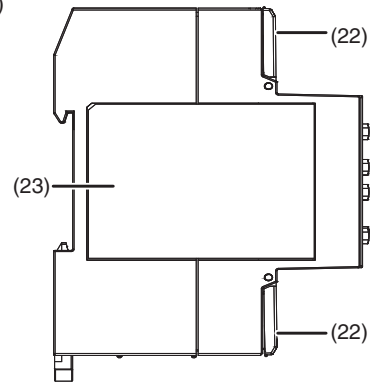

| No. | Item | Description | |
|------|---|--|--|
| (1) | Power indicator (green) | Lights when the power supply is turned ON. | |
| (2) | Error indicator (red) | Flashes when there is an abnormality, such as a failure. | |
| (3) | Alarm indicator (orange) | Flashes when there is an alarm. | |
| (4) | Communications indicator (yellow) | Lit during communications. | |
| (5) | Pulse indicator (yellow) | Lit while pulses are being output from OUT1 (circuit A). | |
| (6) | Communications address and menu display | When ADDRESS is lit (Measurement Mode), the communications address is being displayed. When MENU is lit (Setting Mode), the menu number is being displayed. | |
| (7) | Status Indicators | SET | Lit in Setting Mode. |
| | | OUTPUT | Lit while a pulse output is being set up. |
| | | 1 | Lit while pulses are being output from OUT1. |
| | | 2 | Lit while pulses are being output from OUT2. |
| | | 3 | Lit while pulses are being output from OUT3. |
| (8) | Measured value/set value display | Main display | Displays the measured value or set value. |
| | | Sub display | Displays the measurement unit or setting name. |
| (9) | Tariff display | Displays the tariff number (T1 to T4) a total active power consumption is being saved. | |
| (10) | CT usage display | Displays the numbers of the CTs (CT1 to CT4) for which measurement or setting operations are in progress. | |
| (11) | <</MODE Key | Short press: Changes the circuit or moves the digit. Long press: Changes the mode. | |
| (12) | ▲ Key | Increments the item or value. | |
| (13) | ▼ Key | Decrements the item or value. | |
| (14) | ENTER Key | Enters the item or value. | |
| (15) | ESC Key | Cancel | |
| (16) | Rotary switches | Set the communications address for circuit A. The left switch (x10) sets the tens place and the right switch (x1) sets the ones place. | |
| (17) | RS-485 communications terminals | RS-485 + (1) | RS-485 + terminal |
| | | RS-485 - (1) | RS-485 - terminal |
| | | RS-485 + (2) | RS-485 + terminal for crossover wiring |
| | | RS-485 - (2) | RS-485 - terminal for crossover wiring |
| | | RS-485 E | RS-485 terminating resistance terminal |
| (18) | Pulse output terminals | OUT1 | Pulse output terminal for circuit A |
| | | OUT2 | Pulse output terminal for circuit B |
| | | OUT3 | Pulse output terminal for circuit C |
| | | OUT4 | Pulse output terminal for circuit D |
| | | COM | Pulse output common terminal |
| (19) | Voltage input terminals | Terminal used to input the power supply voltage. These terminals are also used for the measured voltage inputs. | |
| (20) | CT input terminals | Terminals used to connect the CT cables for CT1 to CT4 | |
| (21) | DIN hook | Hook used to mount the Power Monitor to a DIN Track | |
| (22) | Terminal block covers | Sealed terminal block covers | |
| (23) | Terminal arrangement label | Label that provides information, such as the model number, power supply voltage, terminal arrangement, and serial number | |

Connection Wiring Diagrams

Three-phase, Four-wire Circuit

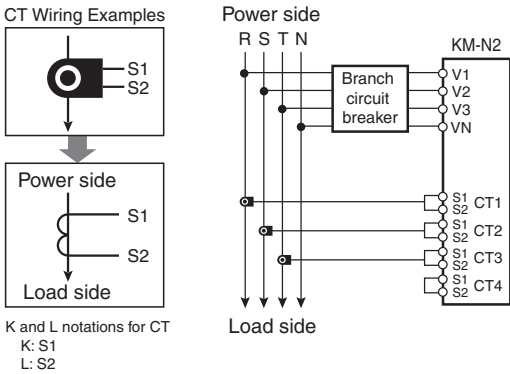

Single-phase, Two-wire Circuit Branched from Single-phase, Three-wire Circuit

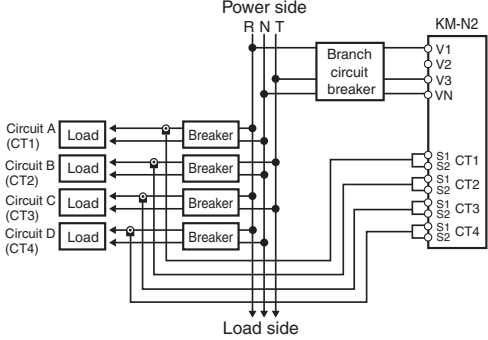

Single-phase, Three-wire Circuit

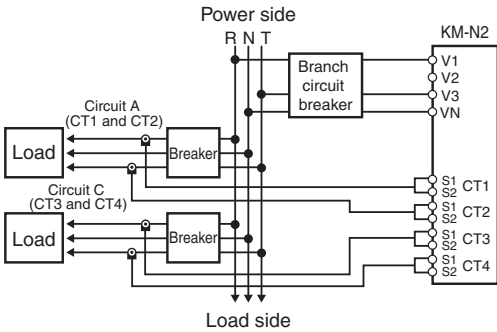

Single-phase, Three-wire Circuit and Single-phase, Two-wire Circuit Branched from Single-phase, Three-wire Circuit

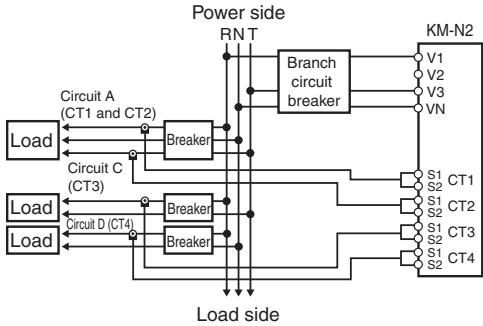

Three-phase, Three-wire Circuit

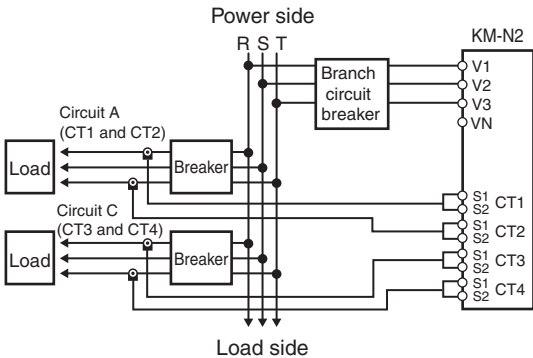

Single-phase, Two-wire Circuit

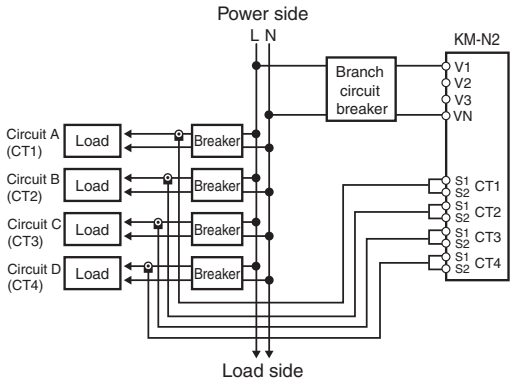

CT Wiring

- For each circuit, one CT is required to measure single-phase two-wire power, two CTs are required to measure single-phase three-wire power or three-phase three-wire power, and three CTs are required to measure three-phase four-wire power.
- Use AWG18 to AWG14 (cross-sectional area: 0.75 to 2.0 mm²) wires with a heat resistance of 85°C min. to connect to the CT input terminals.
- Use ferrules suitable for the wire diameter to connect to the CT input terminals.
- The recommended tightening torque for M3 terminal screws is 0.5 to 0.6 N·m. Push ferrules all the way in and tighten the screws securely.

Voltage Wiring (Power supply voltage and measurement voltage are shared.)

- The Power Monitor has voltage input terminals V1, V2, V3, and VN, which function as both the operating power supply terminals and voltage measurement terminals.
- Connect a branch circuit breaker between the voltage input terminals and the wiring so that the power supply can be turned OFF immediately.
- For safety, always work with the power supply turned OFF both at the main power supply and at the branch circuit breaker.
- Connect the wires in the correct phase sequence. Otherwise, the power and power consumption cannot be measured correctly.
- When wiring the power supply and measured voltage terminals, use round or forked crimp terminals (6.7 mm wide or less) suitable for M3.5 screws and AWG24 to AWG14 (cross-sectional area: 0.2 to 2.0 mm²) wires.
- Recommended tightening torque for M3.5 terminal screws: 0.8 N·m. Push crimp terminals all the way in and tighten the screws securely. After securing the wiring, gently pull on the cables to check that they are held securely.
- Always use the Power Monitor with the terminal covers closed.

Wiring Diagram

The following table shows the relationship between the wire phases connected to the voltage input terminals and CT input terminals for each phase wiring method.

| | Phase wires connected to voltage input terminals | | | | Phase wires connected to CT input terminals | | | | Number of measured circuits |
|----------------------|--|--------------|--------------|--------------|---|-----------|-----------|-----------|-----------------------------|
| | V1 | V2 | V3 | VN | CT1 | CT2 | CT3 | CT4 | |
| Single-phase, 2-wire | Phase L (VR) | --- | --- | Phase N (VN) | Phase L 1 | Phase L 2 | Phase L 3 | Phase L 4 | 4 |
| Single-phase, 3-wire | Phase R (VR) | --- | Phase T (VT) | Phase N (VN) | Phase R 1 | Phase T 1 | Phase R 2 | Phase T 2 | 2 |
| Three-phase, 3-wire | Phase R (VR) | Phase S (VS) | Phase T (VT) | --- | Phase R 1 | Phase T 1 | Phase R 2 | Phase T 2 | 2 |
| Three-phase, 4-wire | Phase R (VR) | Phase S (VS) | Phase T (VT) | Phase N (VN) | Phase R | Phase S | Phase T | --- | 1 |

Note: The numbers in “phase L 1” and “phase L 2” indicate the number of the circuit.

RS-485 Communications Wiring Diagram

- The connection configuration is 1:1 or 1:N. For a 1:N configuration, up to 99 nodes can be connected for Modbus and up to 31 nodes can be connected for CompoWay. If you measure more than one circuit with one Power Monitor, the number of circuits is treated as the number of connected Power Monitors.
- The terminal block has push-in terminals. When wiring, observe the Precautions for Correct Use in *Wires and Precautions for Using Push-in Plus Terminal Blocks (RS-485 Communications Terminals and Pulse Output Terminals)*.
- The KM-N2 does not have a FG terminal. Connect only the positive and negative lines for RS-485.
- Use twisted-pair cables.
- Wire the RS-485 communications lines and power lines separately to prevent the influences of noise.
- The maximum transmission distance is 1,200 m.
- Always test communications on the actual system regardless of the transmission distances and number of connected Power Monitors.
- Always close the terminal block covers before you use the Power Monitor.

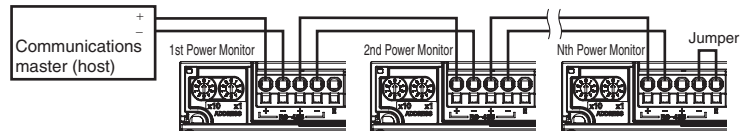

Communications Address Setting

Turn the rotary switches for the 1s and 10s positions and set the communications address for circuit A.

- The value on the rotary switches is assigned as the communications address for circuit A (1st circuit). When multiple addresses are used, the values given in the following table are allocated automatically.
- The communications addresses for circuit B through circuit D cannot be set individually.

Rotary switch for 10s position
Rotary switch for 1s position

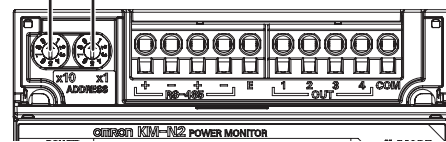

| | Circuit A | Circuit B | Circuit C | Circuit D |
|--|-----------|--------------|--------------|--------------|
| Three-phase, four-wire | Set value | --- | --- | --- |
| Single-phase, two-wire circuit branched from single-phase, two-wire circuit or single-phase, three-wire circuit | Set value | Set value +1 | Set value +2 | Set value +3 |
| Single-phase, three-wire circuit or three-phase, three-wire circuit | Set value | --- | Set value +1 | --- |
| Single-phase, three-wire circuit and single-phase, two-wire circuit branched from single-phase, three-wire circuit | Set value | --- | Set value +1 | Set value +2 |

Terminating Resistance Setting

- The Power Monitor has terminating resistance built in. On the last node on the communications line, connect a jumper between the RS-485 negative terminal and the RS-485 E terminal. The internal terminating resistance will be connected.
- When using a host that does not have built-in terminating resistance, connect terminating resistance to the host as well. The terminating resistance is 120 Ω (1/2 W).
- Do not wire terminating resistance to the KM-N2 partway along the transmission path. Communications failures may occur.

Pulse Output Wiring Diagrams

NPN Output Connection Diagram

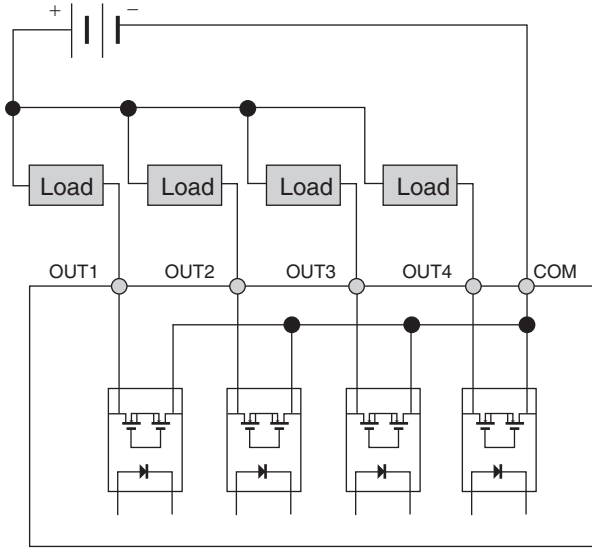

PNP Output Connection Diagram

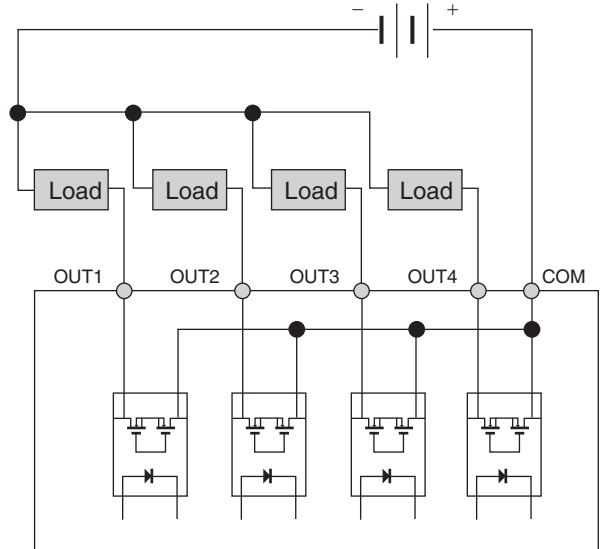

The Power Monitor provides four pulse output terminals. One common is used.

- The terminal block has push-in terminals. When wiring, observe the Precautions for Correct Use in *Wires and Precautions for Using Push-in Plus Terminal Blocks (RS-485 Communications Terminals and Pulse Output Terminals)*.
- Never connect an external power supply directly between an output terminal and the common. Always connect a load.
- Wire signal lines and power lines separately to prevent the influences of noise.
- The outputs are assigned as follows and cannot be changed: OUT1 is for circuit A, OUT2 is for circuit B, OUT3 is for circuit C, and OUT4 is for circuit D.

Dimensions

(Unit: mm)

Power Monitor

KM-N2-FLK

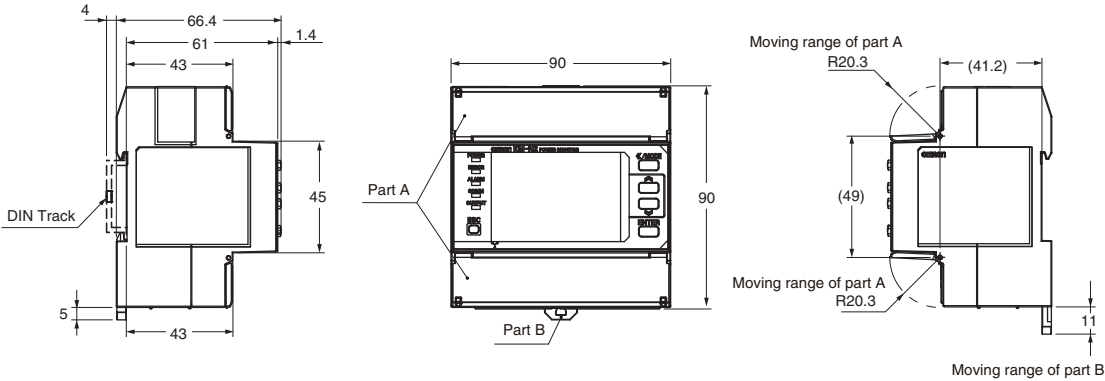

KM-NCT-E100A
KM-NCT-E250A
KM-NCT-E500A
 (CE marking compliant
 KM-N2/N3 dedicated
 products *)

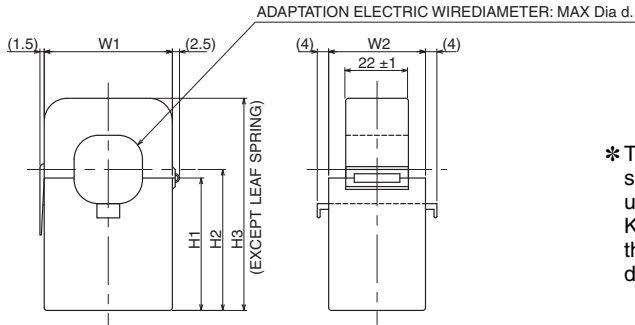

* The KM-NCT-E conforms to the standards shown above ONLY when it is used with a power monitor KM-N2-FLK or KM-N3-FLK to which it is attached. Use of the KM-NCT-E without a power monitor does not conform to these standards.

| Dimension (mm) | Dia. d | W1 | W2 | H1 | H2 | H3 |
|----------------|--------|--------|----------|----------|----------|----------|
| KM-NCT-E100A | 24 | 45 ± 2 | 34 ± 2 | 46.5 ± 1 | 49.5 ± 1 | 74.5 ± 1 |
| KM-NCT-E250A | 24 | 45 ± 2 | 34 ± 2 | 46.5 ± 1 | 49.5 ± 1 | 74.5 ± 1 |
| KM-NCT-E500A | 36 | 57 ± 2 | 40.5 ± 2 | 56.5 ± 1 | 61 ± 1.5 | 91 ± 2 |

Power Monitor KM-N3-FLK

Global Power Monitor for On-panel Installation



- Solve design, installation, and operation topics.
- You can measure up to four circuits with one Power Monitor.
- Use general-purpose CTs and handle a variety of worksites.
- Large, easy-to-read white and green LCD for improved visibility.
- IEC Class 0.5S high-precision measurements (Power Monitor only).



NEW

⚠ Refer to Safety Precautions on page 19.

For the most recent information on models that have been certified for safety standards, refer to your OMRON website.

Ordering Information

Power Monitor

| Model | Applicable phase wiring methods | Power supply voltage | Dimensions | Communications |
|-----------|--|--|---|-------------------------------------|
| KM-N3-FLK | Single-phase, 2-wire: 100 to 277 VAC Single-phase, 3-wire: 100 to 240 VAC (L-N) or 200 to 480 VAC (L-L) Three-phase, 3-wire: 173 to 480 VAC (L-L) Three-phase, 4-wire: 100 to 277 VAC (L-N) or 173 to 480 VAC (L-L) | 100 to 240 VAC Separate from measurement voltage. | 96 × 96 × 64 mm (H×W×D) (excluding protrusions) | RS-485 communications, pulse output |

To use a commercially available current transformer, use a CT with a secondary current rating of 1 A or 5 A, and a rated load of at least 1.0 VA.

Optional Products (Order Separately)

Terminal Covers

| Model |
|------------------|
| E53-COV24 (3pcs) |

Mounting Adapter

| Model |
|----------------|
| Y92F-51 (2pcs) |

Note: This Mounting Adapter is provided with the KM-N3.

Waterproof Packing

| Model |
|----------|
| Y92S-P10 |

Note: This Waterproof Packing is provided with the KM-N3.

Split Type Current Transformer (CT) (CE marking compliant KM-N2/N3 dedicated products *)

| Model | Rated primary current | Rated secondary current |
|--------------|-----------------------|-------------------------|
| KM-NCT-E100A | 100 A | 1 A |
| KM-NCT-E250A | 250 A | |
| KM-NCT-E500A | 500 A | |

* The KM-NCT-E conforms to the standards shown above ONLY when it is used with a power monitor KM-N2-FLK or KM-N3-FLK to which it is attached. Use of the KM-NCT-E without a power monitor does not conform to these standards.

Note: Select a CT cable that does not exceed the rated load of 1 VA.

Specifications

Ratings (Power Monitor)

| Item | Model | KM-N3-FLK |
|--|--------------------------------|--|
| Applicable phase wiring methods | | Single-phase two-wire, single-phase three-wire, three-phase three-wire, and three-phase four-wire |
| Number of measured circuits | | Single-phase two-wire: 4 circuits max., Single-phase three-wire or three-phase three-wire: 2 circuits max., Three-phase four-wire: 1 circuit |
| Power supply voltage (operating frequency) | | 100 to 240 VAC (50/60 Hz) |
| Power supply allowable voltage range | | 85% to 110% of rated power supply voltage |
| Power consumption | | 7 VA max. |
| Input | Rated input voltages | Single-phase, 2-wire: 100 to 277 VAC Single-phase, 3-wire: 100 to 240 VAC (L-N) or 200 to 480 VAC (L-L) Three-phase, 3-wire: 173 to 480 VAC (L-L) Three-phase, 4-wire: 100 to 277 VAC (L-N) or 173 to 480 VAC (L-L) |
| | Allowable supply voltage range | 85% to 115% of rated power supply voltage |
| | Connectable CTs | General-purpose CT with a rated secondary current of 1 A or 5 A * |
| | Maximum CT secondary current | 6 A |
| | Rated input frequency | 50/60 Hz |
| Ambient operating temperature | | -25 to 55°C (with no condensation or icing) |
| Ambient operating humidity | | 25% to 85% |
| Storage temperature | | -25 to 85°C (with no condensation or icing) |
| Storage humidity | | 25% to 85% |
| Operating altitude | | 2,000 m max. |
| Installation environment | | Overvoltage category II, measurement category II, pollution degree 2 |
| Electromagnetic environment | | Industrial electromagnetic environment (EN/IEC 61326-1 Table 2) |
| Compliant standards | | EN 61010-2-030, EN 61326-1, and UL 61010-1 |

* The KM-series CTs (the KM20-CTF or KM-NCT Series) cannot be used. Use general-purpose CTs with a secondary-side output of 1 A or 5 A.

Split Type Current Transformer (CT) (CE marking compliant KM-N2/N3 dedicated products *)

| Item | KM-NCT-E100A | KM-NCT-E250A | KM-NCT-E500A |
|--|---|---------------|---------------|
| Rated primary current: In | 100 A | 250 A | 500 A |
| Rated secondary current: Is | 1 A | | |
| Rated frequency | 50/60 Hz | | |
| Cable Length | Please refer to <i>Writing to KM-NCT-E□□□A</i> | | |
| Rated load | 1 VA | | |
| Insulation resistance | 100 MΩ min. (at 500 VDC mega) between core and all output terminals | | |
| Dielectric strength voltage | 2300 VAC, 1 minute between core and all output terminals. | | |
| Weight | Approx. 170 g | Approx. 175 g | Approx. 290 g |
| Maximum wire diameter | 24 dia. | 24 dia. | 36 dia. |
| Operating temperature and humidity range | -20 to 55 °C, relative humidity: 85% max. with no condensation | | |
| Storage temperature and humidity range | -30 to 90 °C, relative humidity: 85% max. with no condensation | | |
| Applicable standards * | EN61010-1, EN61010-2-030, EN61326-1 | | |
| Installation environment | Overvoltage category and measurement category: II, Pollution level: 2 | | |

* The KM-NCT-E conforms to the standards shown above ONLY when it is used with a power monitor KM-N2-FLK or KM-N3-FLK to which it is attached. Use of the KM-NCT-E without a power monitor does not conform to these standards.

Wiring to KM-NCT-E□□□A

- For wiring of the output terminal of CT, use AWG18-14 electric wire (with a cross-section of 0.75-2.0mm²) and Y-shape terminal compatible with the M3 screw.
- The recommended torque for screwing the M3 screws onto the output terminal is 0.3 N·m. Make sure the Y terminal is pushed all the way in and tightened firmly. After fixing the wiring, confirm that the wire is fixed securely.
- The guideline of the maximum wiring length between KM-N2-FLK or KM-N3-FLK and KM-NCT-E is as follows. The longer the wire length, the larger the measurement error using the KM-NCT-E becomes.
- The limit of the wiring length can also be calculated by the following formula. Calculate the wiring length limit according to the conductor resistivity of the wiring and keep the wiring length below the limit.
- The limits of the wiring length shown below are for reference only. They do not guarantee proper use.

| Wiring diameter | Guideline for wiring length limit |
|---|-----------------------------------|
| 0.75 mm ² (AWG18 equivalent) | 15 m |
| 2.0 mm ² (AWG14 equivalent) | 43 m |

$$\text{Wiring extension limit value (one-way) (m)} = \frac{0.475}{\text{conductor resistivity } (\Omega/\text{m})}$$

Note: Select a CT cable that does not exceed the rated load of 1 VA.

Performance (Power Monitor)

| Item | Model | KM-N3-FLK |
|----------------------------------|--|---|
| Measured items | | Total power consumption (active, regenerative, and reactive), power (active and reactive), current, voltage, power factor, and frequency |
| Measurement specifications | Active power | 0.5% (IEC 62053-22 class 0.5S *) |
| | Reactive power | 2% (IEC 62053-23 class 2) * |
| | Sampling cycle | 80 ms for 50 Hz and 66.7 ms for 60 Hz |
| Insulation resistance | | (1) Between all electrical circuits and the case: 20 MΩ min. (at 500 VDC) (2) Between all power supply and voltage inputs and all communications and pulse output terminals: 20 MΩ max. (at 500 VDC) |
| Dielectric strength | | (1) Between all electrical circuits and the case: 1,400 VAC for 1 min (2) Between all voltage and current inputs and all communications and pulse output terminals: 1,400 VAC for 1 min |
| Vibration resistance | | Single amplitude: 0.1 mm, Acceleration: 15 m/s ² , Frequency: 10 to 150 Hz, 10 sweeps for 8 min each along three axes |
| Shock resistance | | 150 m/s ² , 3 times each in 6 directions (up/down, left/right, forward/backward) |
| Indications and operation method | | LCD indications and operation buttons |
| Weight | | Approx. 350 g (Power Monitor only) |
| Degree of protection | | Front: IP65, Rear case: IP20, Terminal: IP00 |
| Pulse output | Number of outputs | Number of outputs: 4 (photoMOS relay outputs) Used for the total power consumption pulse output. |
| | Output capacity | 50 mA at 40 VDC ON residual voltage: 1.5 V max. (for output current of 50 mA) OFF leakage current: 0.1 mA max. |
| | Output unit | Output unit: 1, 10, 100, 1k, 5k, 10k, 50k, or 100k (wh) Pulse ON time: 500 ms (Cannot be changed.) |
| Communications interface | Communications method | RS-485 (2-wire half-duplex with start-stop synchronization) |
| | Communications protocol | Modbus (RTU): Binary. CompoWay/F: ASCII |
| | Baud rate | 1.2, 2.4, 4.8, 9.6, 19.2, or 38.4 kbps |
| | Data length | Data length: 7 or 8 bits Stop bits: 1 or 2 bits Vertical parity: Even, odd, or none |
| | Maximum transmission distance | 1,200 m |
| | Maximum number of connected Power Monitors | Modbus: 99, CompoWay/F: 31 If you measure more than one circuit with one Power Monitor, the number of circuits is treated as the number of connected Power Monitors. |
| Dimensions (HxWxD) | | 96 × 96 × 64 mm (excluding protrusions) |
| Installation method | | On-panel installation |
| Accessories | | Instruction Manual and Compliance Sheet, Mounting adapter and waterproof packing |

* The error of the CT or VT is not included. IEC 62053 is an international standard for power metering.

Part Names and Functions

Power Monitor

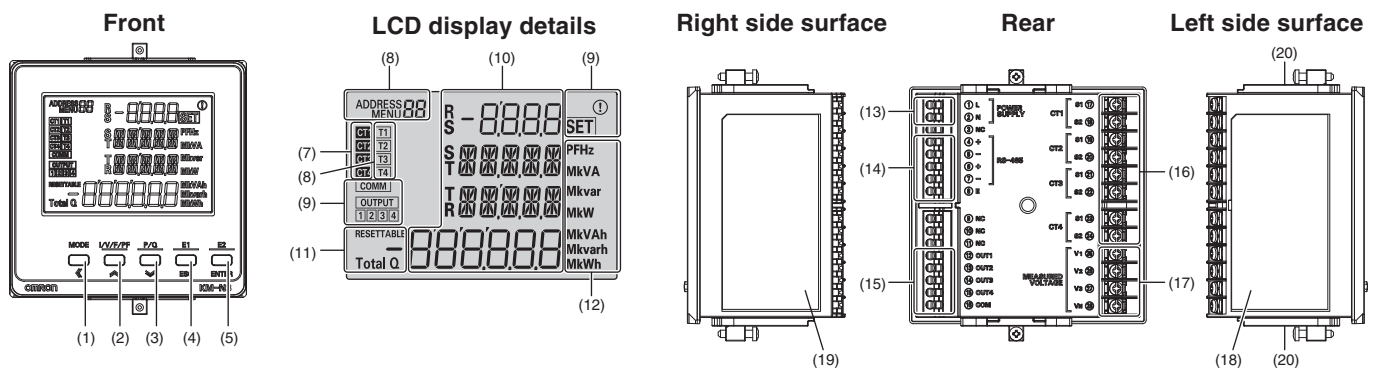

| No. | Item | Description |
|-----|----------------|---|
| (1) | MODE ◀ key | Long press: The measurement mode is switched with the setup mode. [MODE] key (measurement mode): The measurement circuit is changed. [◀] key (setup mode): Change of the measurement circuit / Digit shifting when a numerical value is input |
| (2) | I/V/F/PF ▶ key | [I/V/F/PF] key (measurement mode): The display of current, voltage, frequency, or power factor is switched. [▶] key (setup mode): Items or values are changed (up) |
| (3) | P/Q ⇄ key | [P/Q] key (measurement mode): The display of effective power or reactive power is switched. [⇄] key (setup mode): Items or values are changed (down) |
| (4) | E1•ESC key | [ESC] key (measurement mode): Cancel [E1] key (setup mode): The display of each integrated electric energy is switched. |

| No. | Item | Description | |
|------|--|---|---|
| (5) | E2•ENTER key | [ENTER] key (measurement mode): Select/Determine [E2] key (setup mode): The display of each resettable integrated electric energy is switched. | |
| (6) | Communication address / Menu display | When ADDRESS is lit (in the measurement mode): The communication address is displayed. When MENU is lit (in the setup mode): The menu number is displayed. | |
| (7) | In-operation CT display | The CT number in the condition of measurement or setup (CT1 to CT4) is displayed. | |
| (8) | Tariff display | The tariff number which is saving the integrated effective energy (T1 to T4) is displayed. | |
| (9) | State display | COMM | Blinks when RS-485 communications are in progress. |
| | | OUTPUT | Lit when the pulse output is set. |
| | | 1 | Lit when pulse is output from OUT 1. |
| | | 2 | Lit when pulse is output from OUT 2. |
| | | 3 | Lit when pulse is output from OUT 3. |
| | | 4 | Lit when pulse is output from OUT 4. |
| | | SET | Lit in the setup mode. |
| (10) | Measured value display / Setup value display | First display / instantaneous value display | Instantaneous values or setup values are displayed (on rows No. 1-3). |
| | | Second display / Integrated value display | The integrated value is displayed (on row No. 4). |
| (11) | Measurement auxiliary display | RESETTABLE | Lit when resettable integrated electric energy is displayed. |
| | | --- | Lit when integrated leading reactive electric energy is displayed. |
| | | Total Q | Lit when total integrated reactive electric energy is displayed. |
| (12) | Unit display | The unit of each measured value is lit. | |
| (13) | Power supply terminal | Power supply voltage is input to this terminal | |
| (14) | RS-485 communication terminal | RS-485 + (1) | RS-485 + terminal |
| | | RS-485 - (1) | RS-485 - terminal |
| | | RS-485 + (2) | RS-485 + terminal (for transition wiring) |
| | | RS-485 - (2) | RS-485 - terminal (for transition wiring) |
| | | RS-485E | RS-485 terminating resistor terminal |
| (15) | Pulse output terminal | OUT1 | Circuit A pulse output terminal |
| | | OUT2 | Circuit B pulse output terminal |
| | | OUT3 | Circuit C pulse output terminal |
| | | OUT4 | Circuit D pulse output terminal |
| | | COM | Common terminal for outputting pulse |
| (16) | CT input terminal | Terminal to connect the CT cable for CT1 to CT4 | |
| (17) | Measured voltage input terminal | Measured voltage is input to this terminal. | |
| (18) | Terminal array label | Model, power supply voltage, terminal array, serial number, and so on are written on this label. | |
| (19) | Wiring label | A wiring diagram of voltage and current is written on this label. | |
| (20) | Mounting adapter | Adapter to fix the main unit to the panel | |

Connection Wiring Diagrams

Three-phase, Four-wire Circuit

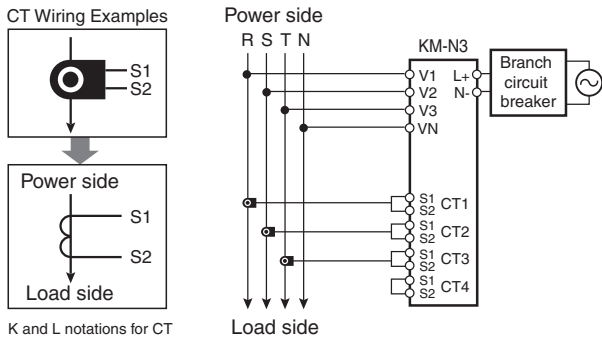

Single-phase, Two-wire Circuit Branched from Single-phase, Three-wire Circuit

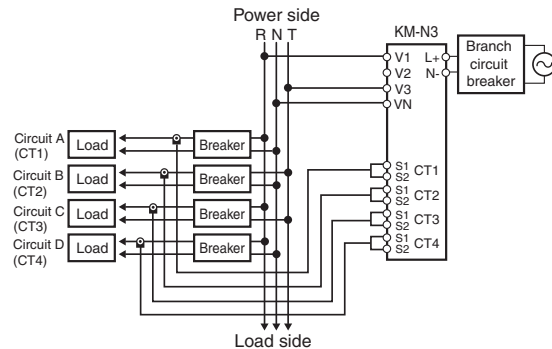

Single-phase, Three-wire Circuit

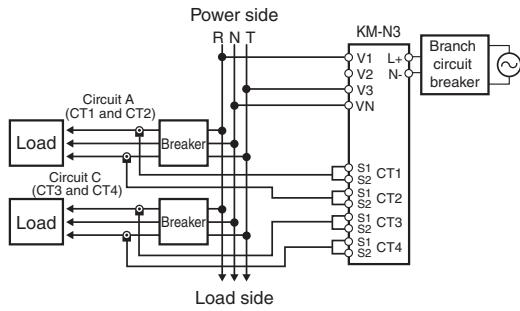

Single-phase, Three-wire Circuit and Single-phase, Two-wire Circuit Branched from Single-phase, Three-wire Circuit

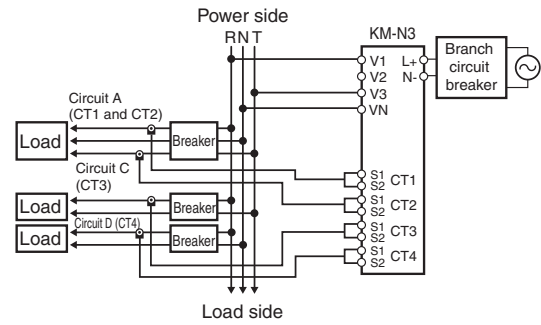

Three-phase, Three-wire Circuit

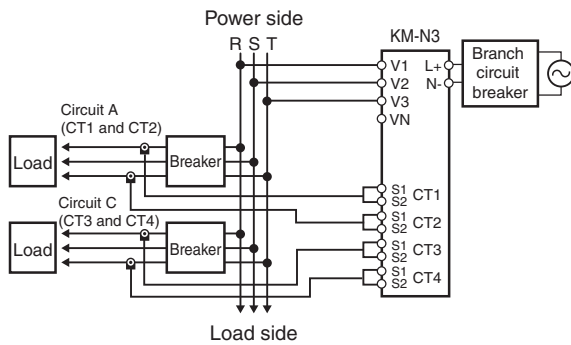

Single-phase, Two-wire Circuit

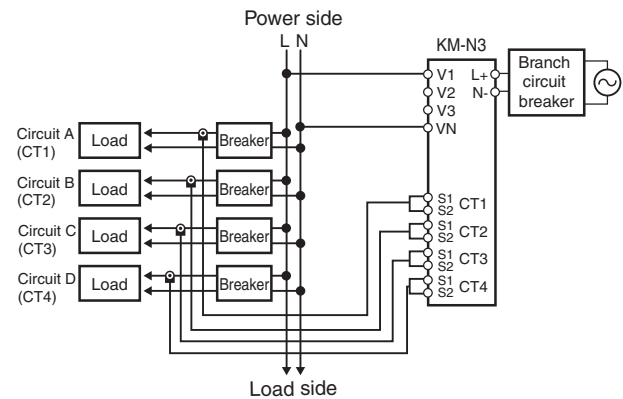

CT Wiring

- For each circuit, one CT is required to measure single-phase two-wire power, two CTs are required to measure single-phase three-wire power or three-phase three-wire power, and three CTs are required to measure three-phase four-wire power.
- Use AWG18 to AWG14 (cross-sectional area: 0.75 to 2.0 mm²) wires and round or forked crimp terminals (5.8 mm wide or less) suitable for M3 screws to connect to the CT input terminals.
- The recommended tightening torque for M3 terminal screws is 0.5 to 0.58 N·m. Push crimp terminals all the way in and tighten the screws securely. After you secure the wires, confirm that they are securely held in place.

Power Supply Wiring

- Connect a branch circuit breaker between the power supply terminal and the wiring so that the power supply can be turned OFF immediately.
- For safety, always work with the power supply turned OFF both at the main power supply and at the branch circuit breaker.
- The terminal block has push-in terminals. When wiring, observe the Precautions for Correct Use in *Wires and Precautions for Using Push-in Plus Terminal Blocks (RS-485 Communications Terminals and Pulse Output Terminals)*.

Wiring Measurement Voltages

- For safety, always work with the power supply turned OFF both at the main power supply.
- Connect the wires in the correct phase sequence. Otherwise, the power and power consumption cannot be measured correctly.
- When wiring the measured voltage terminals, use round or forked crimp terminals (5.8 mm wide or less) suitable for M3 screws and AWG18 to AWG14 (cross-sectional area: 0.75 to 2.0 mm²) wires.
- Recommended tightening torque for M3 terminal screws: 0.5 to 0.58 N·m. Push crimp terminals all the way in and tighten the screws securely. After securing the wiring, gently pull on the cables to check that they are held securely.

Wiring Diagram

The following table shows the relationship between the wire phases connected to the voltage input terminals and CT input terminals for each phase wiring method.

| | Phase wires connected to voltage input terminals | | | | Phase wires connected to CT input terminals | | | | Number of measured circuits |
|----------------------|--|--------------|--------------|--------------|---|-----------|-----------|-----------|-----------------------------|
| | V1 | V2 | V3 | VN | CT1 | CT2 | CT3 | CT4 | |
| Single-phase, 2-wire | Phase L (VR) | --- | --- | Phase N (VN) | Phase L 1 | Phase L 2 | Phase L 3 | Phase L 4 | 4 |
| Single-phase, 3-wire | Phase R (VR) | --- | Phase T (VT) | Phase N (VN) | Phase R 1 | Phase T 1 | Phase R 2 | Phase T 2 | 2 |
| Three-phase, 3-wire | Phase R (VR) | Phase S (VS) | Phase T (VT) | --- | Phase R 1 | Phase T 1 | Phase R 2 | Phase T 2 | 2 |
| Three-phase, 4-wire | Phase R (VR) | Phase S (VS) | Phase T (VT) | Phase N (VN) | Phase R | Phase S | Phase T | --- | 1 |

Note: The numbers in "phase L 1" and "phase L 2" indicate the number of the circuit.

RS-485 Communications Wiring Diagram

- The connection configuration is 1:1 or 1:N. For a 1:N configuration, up to 99 nodes can be connected for Modbus and up to 31 nodes can be connected for CompoWay. If you measure more than one circuit with one Power Monitor, the number of circuits is treated as the number of connected Power Monitors.
- The terminal block has push-in terminals. When wiring, observe the Precautions for Correct Use in *Wires and Precautions for Using Push-in Plus Terminal Blocks (RS-485 Communications Terminals and Pulse Output Terminals)*.

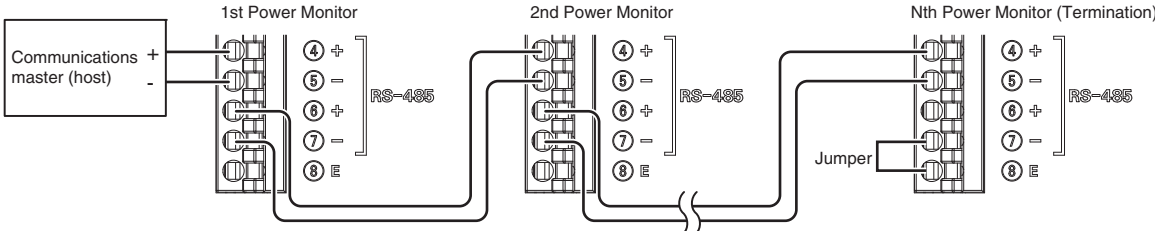

- The KM-N3 does not have a FG terminal. Connect only the positive and negative lines for RS-485.
- Use twisted-pair cables.
- Wire the RS-485 communications lines and power lines separately to prevent the influences of noise.
- The maximum transmission distance is 1,200 m.
- Always test communications on the actual system regardless of the transmission distances and number of connected Power Monitors.

Communications Address Setting

- Change to Setting Mode and set the communications address for circuit A. Refer to the Instruction Manual for the communications address setting method. If the multi-address function is used, the addresses in the following table are automatically allocated based on the communications address set for circuit A (the first circuit).
- The communications addresses for circuit B through circuit D cannot be set individually.

| | Circuit A | Circuit B | Circuit C | Circuit D |
|--|-----------|--------------|--------------|--------------|
| Three-phase, four-wire | Set value | --- | --- | --- |
| Single-phase, two-wire circuit branched from single-phase, two-wire circuit or single-phase, three-wire circuit | Set value | Set value +1 | Set value +2 | Set value +3 |
| Single-phase, three-wire circuit or three-phase, three-wire circuit | Set value | --- | Set value +1 | --- |
| Single-phase, three-wire circuit and single-phase, two-wire circuit branched from single-phase, three-wire circuit | Set value | --- | Set value +1 | Set value +2 |

Terminating Resistance Setting

- The Power Monitor has terminating resistance built in. On the last node on the communications line, connect a jumper between the RS-485 negative terminal and the RS-485 E terminal. The internal terminating resistance will be connected.
- When using a host that does not have built-in terminating resistance, connect terminating resistance to the host as well. The terminating resistance is 120 Ω (1/2 W).
- Do not wire terminating resistance to the KM-N3 partway along the transmission path. Communications failures may occur.

Pulse Output Wiring Diagrams

NPN Output Connection Diagram

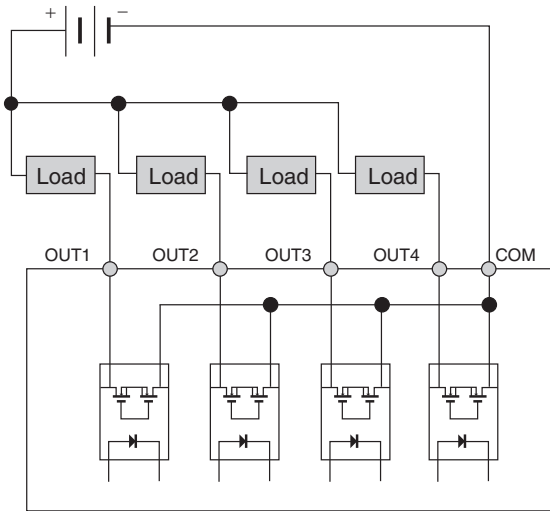

PNP Output Connection Diagram

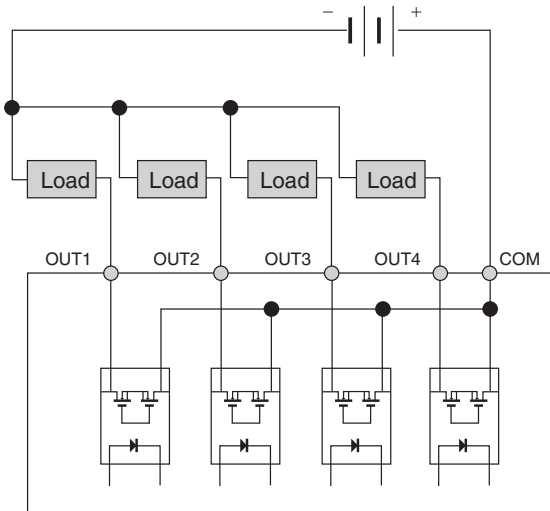

- The Power Monitor provides four pulse output terminals. One common is used.
- The terminal block has push-in terminals. When wiring, observe the Precautions for Correct Use in *Wires and Precautions for Using Push-in Plus Terminal Blocks (RS-485 Communications Terminals and Pulse Output Terminals)*.
 - Never connect an external power supply directly between an output terminal and the common. Always connect a load.
 - Wire signal lines and power lines separately to prevent the influences of noise.
 - The outputs are assigned as follows and cannot be changed: OUT1 is for circuit A, OUT2 is for circuit B, OUT3 is for circuit C, and OUT4 is for circuit D.

KM-N3-FLK

Dimensions

(Unit: mm)

Power Monitor

KM-N3-FLK

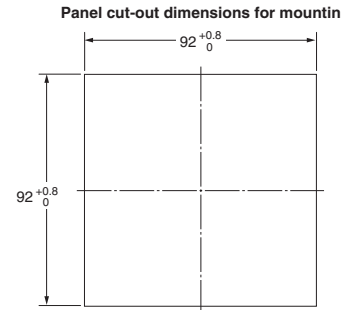
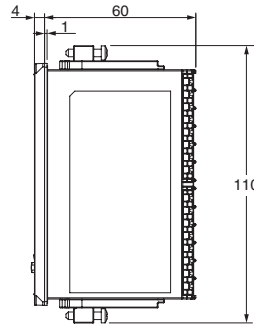
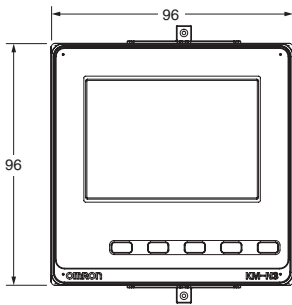
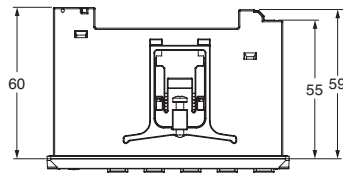

KM-NCT-E100A
KM-NCT-E250A
KM-NCT-E500A
 (CE marking compliant
 KM-N2/N3 dedicated
 products *)

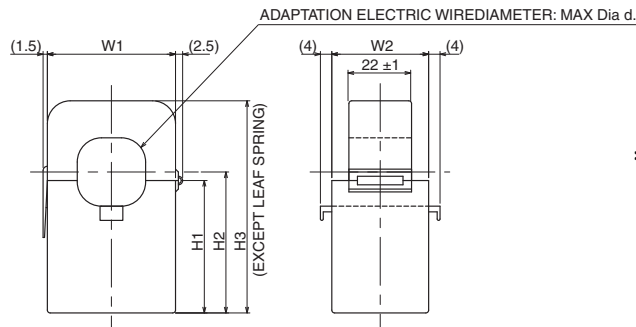

* The KM-NCT-E conforms to the standards shown above ONLY when it is used with a power monitor KM-N2-FLK or KM-N3-FLK to which it is attached. Use of the KM-NCT-E without a power monitor does not conform to these standards.

| Dimension (mm) | Dia. d | W1 | W2 | H1 | H2 | H3 |
|----------------|--------|--------|----------|----------|----------|----------|
| KM-NCT-E100A | 24 | 45 ± 2 | 34 ± 2 | 46.5 ± 1 | 49.5 ± 1 | 74.5 ± 1 |
| KM-NCT-E250A | 24 | 45 ± 2 | 34 ± 2 | 46.5 ± 1 | 49.5 ± 1 | 74.5 ± 1 |
| KM-NCT-E500A | 36 | 57 ± 2 | 40.5 ± 2 | 56.5 ± 1 | 61 ± 1.5 | 91 ± 2 |

Optional Products (Order Separately)

Terminal Covers

E53-COV24 (Three Covers provided.)

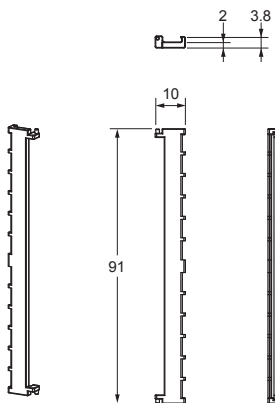

Waterproof Packing

Y92S-P10 (for DIN 96 × 96)

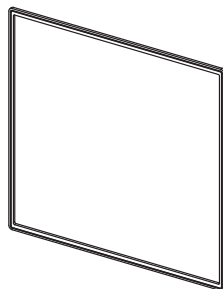

The Waterproof Packing is provided with the KM-N3. Order the Waterproof Packing separately if it becomes lost or damaged. The Waterproof Packing for the front-panel Setup Tool port must be periodically replaced because they may deteriorate, shrink, or harden depending on the operating environment. The replacement period will vary with the operating environment. Check the required period in the actual application. Use 3 years or sooner as a guideline.

Mounting Adapter

Y92F-51 (Two Adapters provided.)

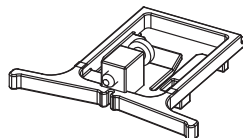

One pair is provided with the KM-N3. Order this Adapter separately if it becomes lost or damaged.

Safety Precautions

Warning Indications

| | | |
|---|----------------|--|
|  | CAUTION | Indicates a potentially hazardous situation which, if not avoided, may result in minor or moderate injury or in property damage. |
|---|----------------|--|

Caution

Property damage may occasionally occur due to fire. Tighten terminal screws to the specified tightening torque.

Confirm that there is no looseness in the screws after tightening them.

M3.5 screws: 0.8 N·m

M3 screws: 0.5 to 0.6 N·m (KM-N2),
0.5 to 0.58 N·m (KM-N3)



Minor or moderate bodily harm or property damage may occasionally occur due to explosion.

Do not use the Power Monitor near inflammable or explosive gas.



Destruction or rupture may occasionally occur.

Make sure that the power supply voltages and loads are within specifications and ratings.



Electrical shock may occasionally occur.

Do not touch any of the terminals while the power is being supplied.



Electric shock may occasionally occur.

Always turn OFF the power supply to the circuit where a CT is mounted before you connect the CT terminals on the Power Monitor.



Electrical shock, minor injury, fire, or equipment malfunction may occasionally occur.

Do not apply a current that exceeds the maximum current for the CT secondary side to the CT input terminals.



Electrical shock, minor injury, fire, or equipment malfunction may occasionally occur.

Do not disassemble, repair, or modify the Power Monitor.



* CT: Current transformer

| | |
|---|---|
|  | <p>Meaning of Warning Symbols</p> <p>Electric shock may occasionally occur. Use wires with a heat resistance of 85°C min. to connect to the voltage input, CT input, and communications terminals.</p> |
|---|---|

Precautions for Safe Use

Observe the following precautions to ensure the safe usage of the KM-N2/N3.

- Do not store, install, or use the Power Monitor in the following locations.
 - Locations that are greatly affected by vibration or shock
 - Unstable locations
 - Locations where the specified range of temperature or humidity would be exceeded
 - Locations that are subject to rapid changes in temperature or humidity where condensation or icing may occur
 - Outdoors or locations that are subject to direct sunlight, wind, or rain
 - Locations that are affected by static electricity or noise
 - Locations that are affected by electric or magnetic fields
 - Locations that are subject to flooding or oil
 - Locations that are subject to splashing brine
 - Locations that are subject to corrosive gas (particularly sulfide or ammonia gas)
 - Locations that are excessively dusty or dirty
 - Locations with miscible liquids
- Be sure to wire properly with the terminals with correct symbols.
- Please use stranded or solid wires with the specified cross section for wiring of the following terminals.
 - KM-N2 voltage input terminal:
 - AWG24 to AWG14 (cross-sectional area: 0.2 to 2.0 mm²)
 - KM-N2 or N3 CT input terminal:
 - AWG18 to AWG14 (cross-sectional area: 0.75 to 2.0 mm²)
 - KM-N3 power supply terminal:
 - AWG20 to AWG16 (cross-sectional area: 0.5 to 1.5 mm²)
 - KM-N3 measured voltage input terminal:
 - AWG18 to AWG14 (cross-sectional area: 0.75 to 2.0 mm²)
- Be sure to check that the wiring is correct before turning on the power.
- Before using or maintaining the product, thoroughly read and understand this manual.
- Understand the user manuals when you set the Power Monitor.
- Do not pull on the cables.
- Do not use any application methods that are not given in the operation manual. Protection implemented in the equipment could be lost.
- Install and suitably label a switch or circuit breaker that is appropriate for the voltage that is being used and complies with the relevant standards for your country so that the operator can immediately turn OFF the power supply. (USA: Use a UL-listed switch or circuit breaker, Canada: Use a cUL-listed switch or circuit breaker, Other countries: Use a branch circuit breaker that complies with IEC 60947-1 and IEC 60947-3 or with other relevant standards.)
 - We recommend that you use a branch circuit breaker with a rated current of 1 A.
- Always check the wiring and confirm that it is correct before turning ON the power supply. Incorrect or improper wiring may result in electrical shock, injury, accidents, failure, or malfunction.
- Do not touch any of the terminals while the power is being supplied.
- Do not install the Power Monitors near sources of heat, such as devices with coils or windings.
- When you install the DIN Tracks, make sure that the screws are tightened securely. Mount the Power Monitor securely to the DIN Track. If the Power Monitor is loose, vibration or shock can cause the DIN Track, Power Monitor, or wires to become disconnected (for the KM-N2).
- Use DIN Tracks with a width of 35 mm (OMRON PFP-50N/-100N) (for the KM-N2).
- If you mount the Power Monitor on DIN Track, slide the DIN hook until it securely and audibly locks in place (for the KM-N2).
- To prevent inductive noise, wire the lines connected to the Power Monitor separately from power lines carrying high voltages or currents. Do not wire in parallel with or in the same cable as power lines. Other measures for reducing noise include running lines in separate ducts and using twisted-pair cables.

- The Power Monitor is a Class A product (for use in industrial environments). In residential environment areas, it may cause radio interference. If it causes radio interference, the user may be required to take adequate measures to reduce interference.
- Install the product in a panel with a panel thickness of 1 to 8 mm. If a suitable panel thickness is not used or the product is installed incorrectly, the product may come free from the mounting (for the KM-N3).

Precautions for Correct Use

- This Power Monitor is not a Special Measuring Instrument that has passed testing by a specified body under the Measurement Act of Japan. It cannot be used to certify power consumption under Japanese law.
- Make sure that all settings are set suitably for the measurement targets.
- When using the Power Monitor in an Overvoltage Category III environment, externally install varistors between the power supply and voltage measurement inputs to the Power Monitor.
- Do not use the Power Monitor for measurement on the secondary side of an inverter.
- Make sure the rated voltage is reached within 2 seconds after the power is turned ON.
- Always turn OFF all power before cleaning the Power Monitor. Dry wipe the surfaces of the Power Monitor with a soft, dry cloth. Never use any chemical that contains solvents such as paint thinner, benzene, or alcohol.
- OMRON's KM-series CTs (e.g., the KM20-CTF or KM-NCT Series) cannot be used. Use CTs with a secondary-side output of 1 A or 5 A.
- To comply with standards, always use ferrules when you connect to the input terminals on CTs (for the KM-N2).
- The total power consumption and other data is saved every 5 minutes. When the power supply to the Power Monitor is turned OFF, the last 5 minutes worth of data may not have been saved.
- When discarding the Power Meter, properly dispose of it as industrial waste according to all applicable local ordinances.

Mounting to and Removing Mounting to and Removing from DIN Track (KM-N2)

- **Mounting a Unit**
Pull down the DIN Track hook on the Terminal Unit and catch the top hook on the DIN Track.
Press the Unit onto the DIN Track until the DIN Track hooks are locked in place.

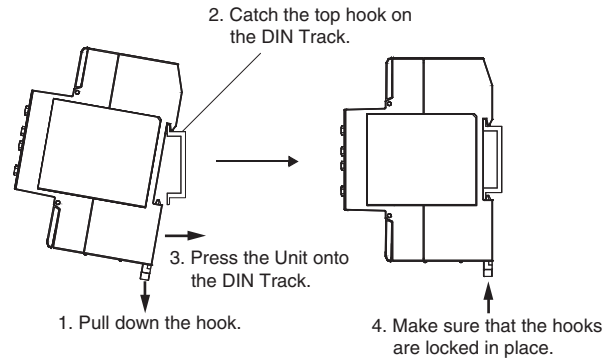

- **Removing a Unit**
Pull down on the DIN Track Hook with a flat-blade screwdriver and lift up the Unit.

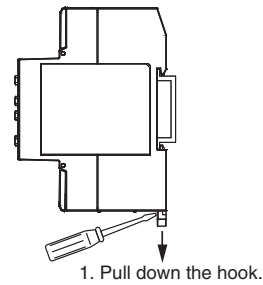

Mounting to a Panel (KM-N3)

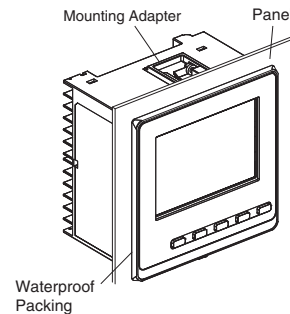

1. In order to make the unit waterproof, with the accessory waterproof packing on the front of the panel, insert the unit into the panel opening.
Unless the waterproof packing is put, the product is not waterproof.
2. Fit the attached mounting adapter into the fixing grooves on the top and bottom faces of the rear case.
3. Push in the mounting adapter from the terminal side until it contacts the panel to fix the main unit tentatively.
4. Fasten the fixing screws of the top and bottom mounting adapter alternately as keeping balance little by little.
Apply a fastening torque of 0.29 to 0.39 N·m.

Mounting the Terminal Cover

Slightly bend the E53-COV24 Terminal Cover to attach it to the terminal block as shown in the following diagram. The Terminal Cover cannot be attached in the opposite direction.

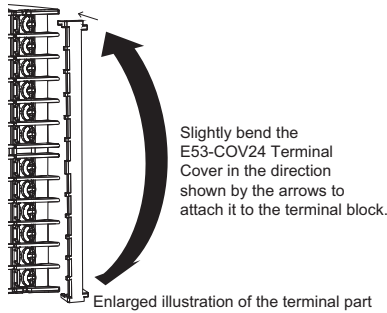

Wires and Precautions for Using Push-in Plus Terminal Blocks (RS-485 Communications Terminals and Pulse Output Terminals)

1. Applicable Wires

- For the KM-N3 power supply wiring, use AWG20 to AWG16 (cross-sectional area: 0.5 to 1.5 mm²) stranded or solid wires.
- Wire used for RS-485 communication terminal and Pulse output terminal. Use stranded or solid wires of AWG24 to AWG16 (cross-sectional area: 0.25 to 1.5 mm²).
- Strip the wires for 10 mm if you use ferrules and for 8 mm if you do not use ferrules.

2. Connecting Wires to the Push-In Plus Terminal Block

Part Names of the Terminal Block
When connecting Push-in Plus Terminal Blocks (RS-485 communications terminals and pulse output terminals), use the following procedure.

KM-N2

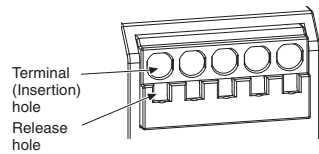

KM-N3

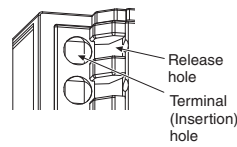

Connecting Wires with Ferrules and Solid Wires

Insert the solid wire or ferrule straight into the terminal block until the end strikes the terminal block.

- If a wire is difficult to connect because it is too thin, use a flat-blade screwdriver in the same way as when connecting stranded wire.

KM-N2

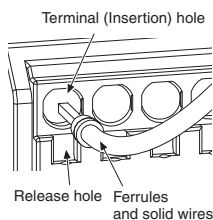

KM-N3

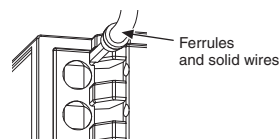

Connecting Stranded Wires

Use the following procedure to connect the wires to the terminal block.

1. Hold a flat-blade screwdriver at an angle and insert it into the release hole.
The angle is the diagram below. If the flat-blade screwdriver is inserted correctly, you will feel the spring in the release hole.
2. With the flat-blade screwdriver still inserted into the release hole, insert the wire into the terminal hole until it strikes the terminal block.
3. Remove the flat-blade screwdriver from the release hole.

KM-N2

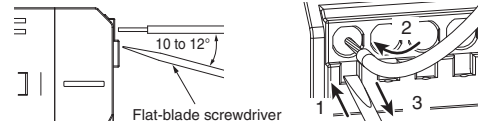

KM-N3

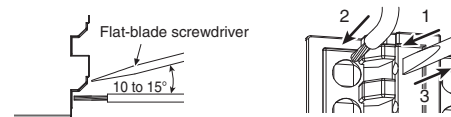

Checking Connections

- After the insertion, pull gently on the wire to make sure that it will not come off and the wire is securely fastened to the terminal block.
- To prevent short circuits, insert the stripped part of a stranded or solid wire or the conductor part of a ferrule until it is hidden inside the terminal insertion hole. (See the following diagram.)

KM-N2

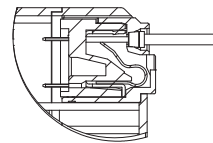

KM-N3

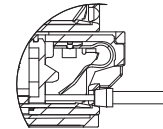

3. Removing Wires from the Push-In Plus Terminal Block

Use the following procedure to remove wires from the terminal block. The same method is used to remove stranded wires, solid wires, and ferrules.

1. Hold a flat-blade screwdriver at an angle and insert it into the release hole.
2. With the flat-blade screwdriver still inserted into the release hole, remove the wire from the terminal insertion hole.
3. Remove the flat-blade screwdriver from the release hole.

KM-N2

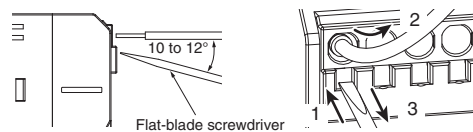

KM-N3

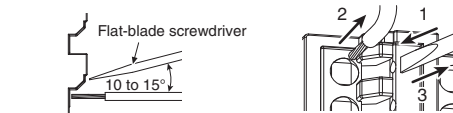

4. Recommended Ferrules and Crimp Tools

Recommended ferrules

| Applicable wire | | Ferrule Conductor length (mm) | Stripping length (mm) (Ferrules used) | Recommended ferrules | | |
|------------------------|-------|-------------------------------|---------------------------------------|---|--------------------|--------------|
| (mm ²) | (AWG) | | | Phoenix Contact product | Weidmuller product | Wago product |
| 0.25 *1 | 24 | 8 | 10 | AI 0,25-8 | H0.25/12 | 216-301 |
| | | 10 | 12 | AI 0,25-10 | --- | --- |
| 0.34 *1 | 22 | 8 | 10 | AI 0,34-8 | H0.34/12 | 216-302 |
| | | 10 | 12 | AI 0,34-10 | --- | --- |
| 0.5 | 20 | 8 | 10 | AI 0,5-8 | H0.5/14 | 216-201 |
| | | 10 | 12 | AI 0,5-10 | H0.5/16 | 216-241 |
| 0.75 | 18 | 8 | 10 | AI 0,75-8 | H0.75/14 | 216-202 |
| | | 10 | 12 | AI 0,75-10 | H0.75/16 | 216-242 |
| 1/1.25 | 18/17 | 8 | 10 | AI 1-8 | H1.0/14 | 216-203 |
| | | 10 | 12 | AI 1-10 | H1.0/16 | 216-243 |
| 1.25/1.5 *2 | 17/16 | 8 | 10 | AI 1,5-8 | H1.5/14 | 216-204 |
| | | 10 | 12 | AI 1,5-10 | H1.5/16 | 216-244 |
| Recommended crimp tool | | | | CRIMPFOX6 CRIMPFOX6-F CRIMPFOX10S | PZ6 roto | Variocrimp4 |

- Note:**
1. Make sure that the outer diameter of the wire coating is smaller than the inner diameter of the insulation sleeve of the recommended ferrule.
 2. Make sure that the ferrule processing dimensions conform to the following figures.

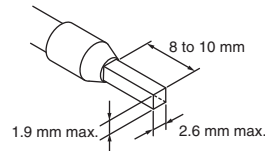

- *1. If you use AWG24 to AWG22 (0.25 to 0.34 mm²) wires, UL certification will not apply.
- *2. Do not connect ferrules for the applicable wires (AWG17 to AWG16 (1.25 to 1.5 mm²)) to adjacent terminal (insertion) holes.

Recommended Flat-blade Screwdriver

Use a flat-blade screwdriver to connect and remove wires.

Use the following flat-blade screwdriver.

The following table shows manufacturers and models as of 2015/Dec.

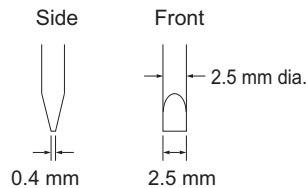

| Model | Manufacturer |
|------------------------------------|-----------------|
| ESD0.40 × 2.5 | Wera |
| SZF 0.4 × 2.5 SZF 0-0.4 × 2.5 * | Phoenix Contact |
| 0.4 × 2.5 × 75 302 | Wiha |
| AEF.2.5 × 75 | Facom |
| 210-719 | Wago |
| SDI 0.4 × 2.5 × 75 | Weidmuller |

* SZF 0-0.4 × 2.5 (Phoenix Contact) is can be arranged from Omron XW4Z-00B.

По вопросам продаж и поддержки обращайтесь:

Архангельск (8182)63-90-72
Астана +7(7172)727-132
Астрахань (8512)99-46-04
Барнаул (3852)73-04-60
Белгород (4722)40-23-64
Брянск (4832)59-03-52
Владивосток (423)249-28-31
Волгоград (844)278-03-48
Вологда (8172)26-41-59
Воронеж (473)204-51-73
Екатеринбург (343)384-55-89
Иваново (4932)77-34-06
Ижевск (3412)26-03-58
Иркутск (395) 279-98-46

Казань (843)206-01-48
Калининград (4012)72-03-81
Калуга (4842)92-23-67
Кемерово (3842)65-04-62
Киров (8332)68-02-04
Краснодар (861)203-40-90
Красноярск (391)204-63-61
Курск (4712)77-13-04
Липецк (4742)52-20-81
Магнитогорск (3519)55-03-13
Москва (495)268-04-70
Мурманск (8152)59-64-93
Набережные Челны (8552)20-53-41
Нижний Новгород (831)429-08-12

Новокузнецк (3843)20-46-81
Новосибирск (383)227-86-73
Омск (3812)21-46-40
Орел (4862)44-53-42
Оренбург (3532)37-68-04
Пенза (8412)22-31-16
Пермь (342)205-81-47
Ростов-на-Дону (863)308-18-15
Рязань (4912)46-61-64
Самара (846)206-03-16
Санкт-Петербург (812)309-46-40
Саратов (845)249-38-78
Севастополь (8692)22-31-93
Симферополь (3652)67-13-56

Смоленск (4812)29-41-54
Сочи (862)225-72-31
Ставрополь (8652)20-65-13
Сургут (3462)77-98-35
Тверь (4822)63-31-35
Томск (3822)98-41-53
Тула (4872)74-02-29
Тюмень (3452)66-21-18
Ульяновск (8422)24-23-59
Уфа (347)229-48-12
Хабаровск (4212)92-98-04
Челябинск (351)202-03-61
Череповец (8202)49-02-64
Ярославль (4852)69-52-93

Киргизия (996)312-96-26-47

Казахстан (772)734-952-31

Таджикистан (992)427-82-92-69

Эл. почта: orm@nt-rt.ru || Сайт: <http://omron.nt-rt.ru>