

# Инверторы серии J1000

## ТЕХНИЧЕСКИЕ ХАРАКТЕРИСТИКИ

**По вопросам продаж и поддержки обращайтесь:**

Архангельск (8182)63-90-72  
Астана +7(7172)727-132  
Белгород (4722)40-23-64  
Брянск (4832)59-03-52  
Владивосток (423)249-28-31  
Волгоград (844)278-03-48  
Вологда (8172)26-41-59  
Воронеж (473)204-51-73  
Екатеринбург (343)384-55-89  
Иваново (4932)77-34-06  
Ижевск (3412)26-03-58  
Казань (843)206-01-48

Калининград (4012)72-03-81  
Калуга (4842)92-23-67  
Кемерово (3842)65-04-62  
Киров (8332)68-02-04  
Краснодар (861)203-40-90  
Красноярск (391)204-63-61  
Курск (4712)77-13-04  
Липецк (4742)52-20-81  
Магнитогорск (3519)55-03-13  
Москва (495)268-04-70  
Мурманск (8152)59-64-93  
Набережные Челны (8552)20-53-41

Нижний Новгород (831)429-08-12  
Новокузнецк (3843)20-46-81  
Новосибирск (383)227-86-73  
Орел (4862)44-53-42  
Оренбург (3532)37-68-04  
Пенза (8412)22-31-16  
Пермь (342)205-81-47  
Ростов-на-Дону (863)308-18-15  
Рязань (4912)46-61-64  
Самара (846)206-03-16  
Санкт-Петербург (812)309-46-40  
Саратов (845)249-38-78

Смоленск (4812)29-41-54  
Сочи (862)225-72-31  
Ставрополь (8652)20-65-13  
Тверь (4822)63-31-35  
Томск (3822)98-41-53  
Тула (4872)74-02-29  
Тюмень (3452)66-21-18  
Ульяновск (8422)24-23-59  
Уфа (347)229-48-12  
Челябинск (351)202-03-61  
Череповец (8202)49-02-64  
Ярославль (4852)69-52-93

JZ

# J1000

## The basic inverter

- V/f controlled inverter
- Good torque performance (150% / 3 Hz)
- Double rating ND 120%/1min and HD 150%/1 min
- Overload detection function (150% during 60s)
- Motor thermal function
- Freely configurable V/f curve
- 5 programmable digital input
- 1 programmable digital output
- 1 programmable analog output
- Optional RS-232C/485 communication - Modbus, CE, UL, cUL and TUV, RoHS

## Ratings

- 200 V Class single-phase 0.1 to 1.5 kW
- 200 V Class three-phase 0.1 to 4.0 kW
- 400 V Class three-phase 0.2 to 4.0 kW



## System configuration

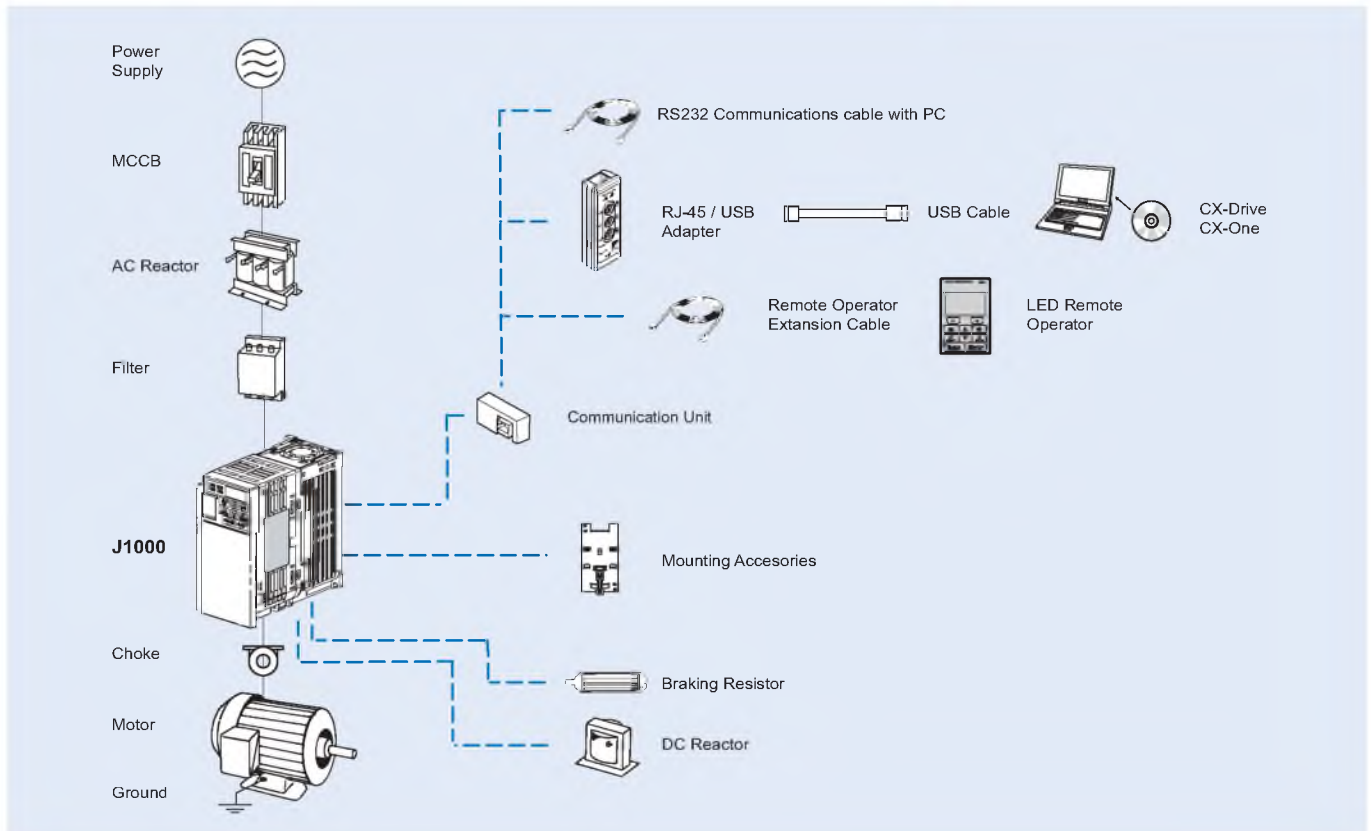

Specifications

Type designation

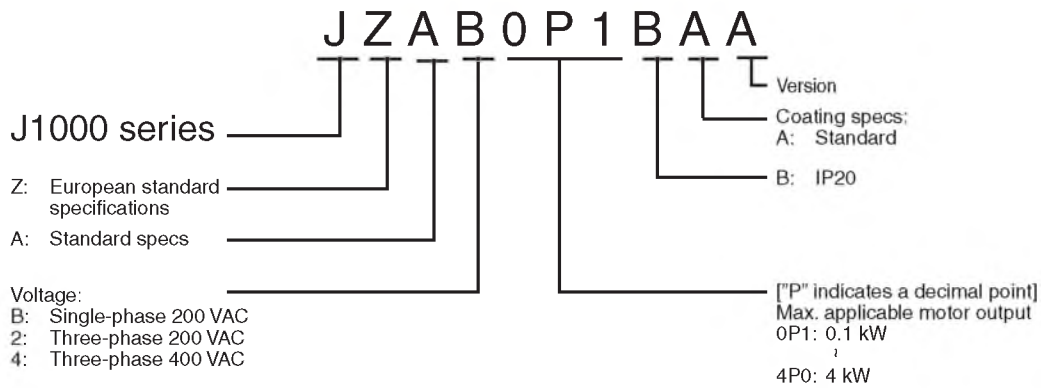

200 V class

Single-phase: JZA□		B0P1	B0P2	B0P4	B0P7	B1P5	-	-
Three-phase: JZA□		20P1	20P2	20P4	20P7	21P5	22P2	24P0
Motor kW <sup>1</sup>	For HD setting	0.12	0.25	0.4	1.1	1.5	2.2	4.0
	For ND setting	0.18	0.37	0.55	1.1	2.2	3.0	5.5 <sup>1</sup>
Output characteristics	Inverter capacity kVA	0.3	0.6	1.1	1.9	3.0	4.2	6.7
	Rated output current (A) at HD	0.8	1.6	3.0	5.0	8.0	11.0	17.5
	Rated output current (A) at ND	1.2	1.9	3.5	6.0	9.6	12.0	21.0
	Max. output voltage	Proportional to input voltage: 0..240 V						
	Max. output frequency	400 Hz						
Power supply	Rated input voltage and frequency	Single-phase 200..240 V 50/60 Hz 3-phase 200..240 V 50/60 Hz						
	Allowable voltage fluctuation	-15%..+10%						
	Allowable frequency fluctuation	+5%						

1. Based on a standard 4-pole motor for maximum applicable motor output:  
Heavy Duty (HD) mode with a 150% overload capacity  
Normal Duty (ND) mode with a 120% overload capacity

400 V class

Three-phase: JZA□		40P2	40P4	40P7	41P5	42P2	43P0	44P0
Motor kW <sup>1</sup>	For HD setting	0.37	0.55	1.10	1.5	2.2	3.0	4.0
	For ND setting	0.37	0.75	1.5	2.2	3.0	4.0	5.5
Output characteristics	Inverter capacity kVA	0.9	1.4	2.6	3.7	4.2	5.5	7.2
	Rated output current (A) at HD	1.2	1.8	3.4	4.8	5.5	7.2	9.2
	Rated output current (A) at ND	1.2	2.1	4.1	5.4	6.9	8.8	11.1
	Max. output voltage	0..480V (proportional to input voltage)						
	Max. output frequency	400 Hz						
Power supply	Rated input voltage and frequency	3-phase 380..480 VAC, 50/60 Hz						
	Allowable voltage fluctuation	-15%..+10%						
	Allowable frequency fluctuation	+5%						

1. Based on a standard 4-pole motor for maximum applicable motor output:  
Heavy Duty (HD) mode with a 150% overload capacity  
Normal Duty (ND) mode with a 120% overload capacity

Specifications

Common specifications

Model number JZA□		Specifications
Control functions	Control methods	V/f control
	Output frequency range	0.1..400 Hz
	Frequency tolerance	Digital set value: ±0.01% (-10..+50 °C)
		Analogue set value: ±0.1% (25 ±10 °C)
	Resolution of frequency set value	Digital set value: 0.01 Hz (<100 Hz), 0.1 Hz (>100 Hz)
	Resolution of output frequency	Analogue set value: 1/1000 of maximum frequency
	Overload capability	0.01 Hz
	Overload capability	Heavy duty use: 150% rated output current for one minute Normal duty use: 120% rated output current for one minute
	Frequency set value	0..10 V (20 kΩ), 4..20 mA (250 Ω), 0..20 mA (250 Ω) Frequency setting value (selectable)
Braking torque (short term peak torque)	Short-term average deceleration torque: 150% (up 1.5 kW), 100% (for 1.5 kW), 50% (for 2.2 kW), 20% (for bigger size) Continuous regenerative torque: Approx 20% (125% with optional braking resistor, 10%ED, 10 s, braking transistor built in)	
V/f Characteristics	Possible to program any V/f pattern	
Functionality	Inputs signals	Five of the following input signals are selectable: Forward/reverse run (3-wire sequence), fault reset, external fault (NO/NC contact input), multi-step speed operation, Jog command, accel/decel time select, external baseblock, speed search command, UP/DOWN command, accel/decel hold command, LOCAL/REMOTE selection, emergency stop fault, emergency stop alarm, self test
	Output signals	Following output signals are selectable (NO/NC contact output, MA, MB and MC relay: Fault, running, zero speed, speed agree, frequency detection (output frequency <= or => set value), undervoltage detection, minor error, during baseblock, operation mode, inverter run ready, during fault retry, reverse running, during speed search.
	Standard functions	Full-range automatic torque boost, slip compensation, 9-step speed operation (max.), restart after momentary power loss, DC injection braking current at stop/start (50% of inverter rated current, 0.5 sec, or less), frequency reference bias/gain, ME-MOBUS communications (Option), fault retry, speed search, frequency upper/lower limit setting, overtorque detection, frequency jump, accel/decel time switch, accel/decel prohibited, S-curve accel/decel
	Analogue inputs	1 analogue input, 0..10 V, 4..20 mA, 0..20 mA
	Braking/acceleration times	0.01..6000 s
	Display	Optionally frequency, current or set value Error and status LED
Protection functions	Motor overload protection	Electronic thermal overload relay
	Instantaneous overcurrent	Motor coasts to a stop at approx. 250% of inverter rated current
	Overload	Heavy Duty: Motor coasts to a stop after 1 minute at 150% of inverter rated output current Normal Duty: Motor coasts to a stop after 1 minute at 120% of inverter rated output current
	Overvoltage	Motor coasts to a stop if DC bus voltage exceed 410 V (double for 400 V class)
	Undervoltage	Stops when DC bus voltage is approx. 190 V or less (double for 400 V class) (approx. 150 V or less for single-phase series)
	Momentary power loss	Following items are selectable: not provided (stop if power loss is 15 ms or longer), continuous operation if power loss is approx. 0.5 s or shorter, continuous operation
	Cooling fin overheat	Protected by thermistor
	Stall prevention level	Stall prevention during acceleration/deceleration and constant speed operation
	Ground fault	Protected by electronic circuit (operation level is approx. 250% of rated output current)
Power charge indication	Indicates until the main circuit voltage reaches 50 V.	
Ambient conditions	Degree of protection	IP20, NEMA1
	Cooling	Cooling fan is provided for 200 V (3-phase) 0.75 kW (1HP) to 4.0 KW, 200V (single-phase) 1.5 KW 400 V 1.5 kW (2HP) to 4.0 KW, others are self-cooling
	Ambient humidity	95% RH or less (without condensation)
	Storage temperature	-20 °C..+60 °C (short-term temperature during transportation)
	Installation	Indoor (no corrosive gas, dust, etc.)
	Installation height	Max. 1000 m
Vibration	Up to 9.8 m/s <sup>2</sup> at 10 to less than 20 Hz, Up to 6.37 m/s <sup>2</sup> at 20 to 50 Hz	

Dimensions

IP 20 type 0.1 to 4 kW

Figure 1

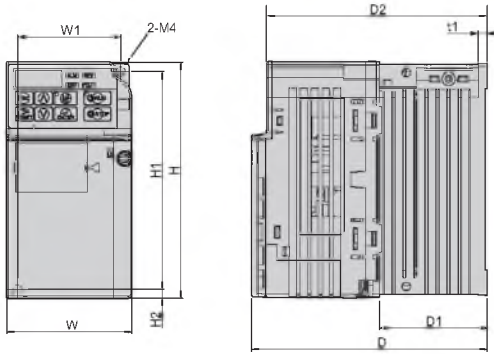
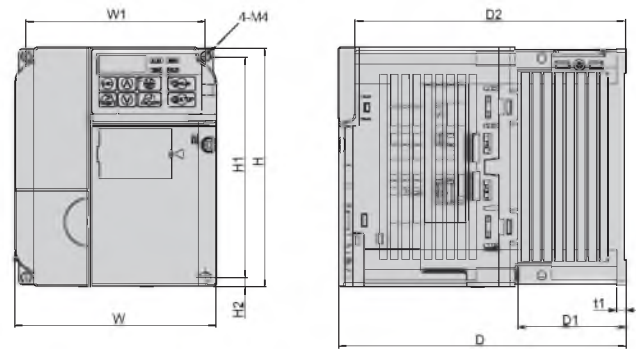
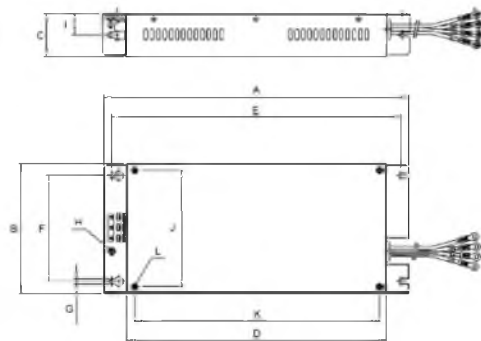

Figure 2



Voltage class	Max. applicable motor output kW	Inverter model JZA□	Figure	Dimensions in mm											
				W1	H1	W	H	D	t1	H2	D1	D2	Weight		
Single-phase 200 V	0.12	B0P1	1	56	118	68	128	76	3	5	6.5	67.5	0.6		
	0.25	B0P2						118					3	6.5	67.5
	0.55	B0P4	2	96		108	118	5	58		129	1.0			
	1.1	B0P7					137.5					1.7			
	1.5	B1P5					154					1.8			
Three-phase 200 V	0.12	20P1	1	56	118	68	128	76	3	5	6.5	67.5	0.6		
	0.25	20P2						108					3	6.5	67.5
	0.55	20P4	2	96		108	128	5	58		129	0.9			
	1.1	20P7					128					1.1			
	1.5	21P5					129					1.7			
	2.2	22P2	137.5	1.7											
	4.0	24P0	140	2.4											
Three-phase 400 V	0.37	40P2	2	96	118	108	128	81	5	5	10	72.5	1.0		
	0.55	40P4						99			28	90.5	1.2		
	1.1	40P7						137.5			58	145.5	1.7		
	1.5	41P5						154					1.7		
	2.2	42P2						143					1.7		
	3.0	43P0						128			140	143	65	134.5	2.4
	4.0	44P0											65	134.5	2.4

Schaffner footprint Filters



Schaffner model		Dimensions												Weight KG
		A	B	C	D	E	F	G	H	I	J	K	L	
3x200 V	A1000-FIV2010-SE	194	82	50	160	181	62	5.3	M5	25	56	118	M4	0.40
	A1000-FIV2020-SE	169	111	50	135	156	91	5.5	M5	25	96	118	M4	0.58
	A1000-FIV2030-SE	174	144	50	135	161	120	5.3	M5	25	128	118	M4	0.90
1x200 V	A1000-FIV1010-SE	169	71	45	135	156	51	5.3	M5	22	56	118	M4	0.44
	A1000-FIV1020-SE	169	111	50	135	156	91	5.3	M5	25	96	118	M4	0.75
3x400 V	A1000-FIV3005-SE	169	111	45	135	156	91	5.3	M5	22	96	118	M4	0.5
	A1000-FIV3010-SE	169	111	45	135	156	91	5.3	M5	22	96	118	M4	0.7
	A1000-FIV3020-SE	174	144	50	135	161	120	5	M5	25	128	118	M4	0.9

Rasmi footprint Filters

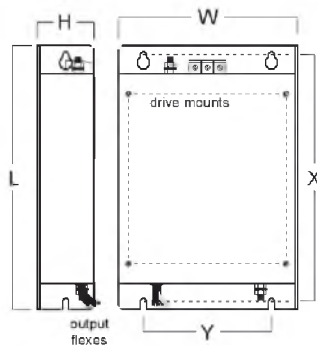

Rasmi model		Dimensions						Weight KG
		W	H	L	X	Y	M	
3x200 V	A1000-FIV2010-RE	82	50	194	181	62	M4	0.8
	A1000-FIV2020-RE	111	50	194	181	62	M4	1.1
	A1000-FIV2030-RE	144	50	174	161	120	M4	1.3
1x200 V	A1000-FIV1010-RE	71	45	169	156	51	M4	0.6
	A1000-FIV1020-RE	111	50	169	156	91	M4	1.0
3x400 V	A1000-FIV3005-RE	111	45	169	156	91	M4	1.1
	A1000-FIV3010-RE	111	45	169	156	91	M4	1.1
	A1000-FIV3020-RE	144	50	174	161	120	M4	1.3

Chokes

Description	D diameter	Motor KW	Dimensions						Weight Kg
			L	W	H	X	Y	m	
A1000-FEV2102-RE	21	< 2.2	85	22	46	70	-	5	0.1
A1000-FEV2515-RE	25	< 15	105	25	62	90	-	5	0.2

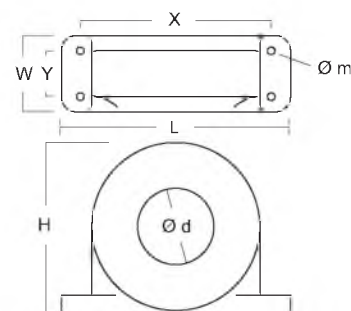

Resistor Dimensions

A1000-REJ0K15xxx

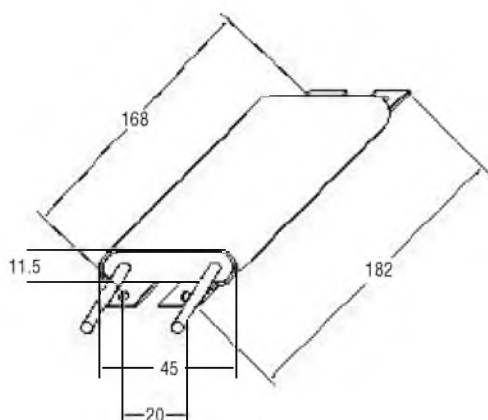

A1000-REJ0K10xxx

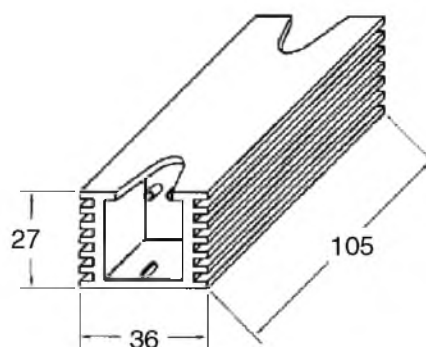

DIN rail mounting bracket

EZZ08122A

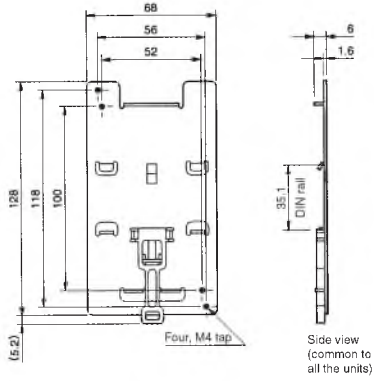

EZZ08122B

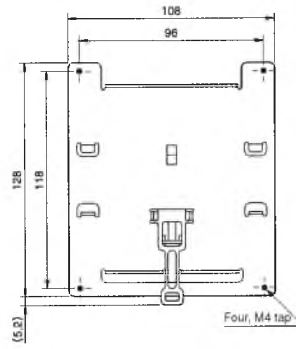

EZZ08122C

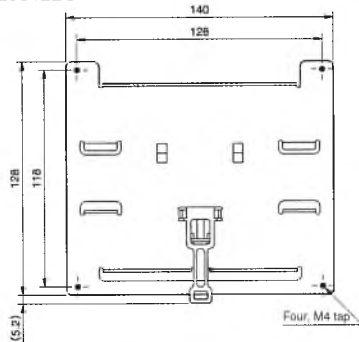

Inverter JZA□		DIN rail mounting bracket
3-phase 200 VAC	20P1/ 20P2 / 20P4/ 20P7	EZZ08122A
	21P5/ 22P2	EZZ08122B
	24P0	EZZ08122C
Single-phase 200 VAC	B0P1/ B0P2/ B0P4	EZZ08122A
	B0P7/ B1P5	EZZ08122B
3-phase 400 VAC	40P2/ 40P4/ 40P7/ 41P5/ 42P2	EZZ08122B
	44P0	EZZ08122C

Installation

Standard connections

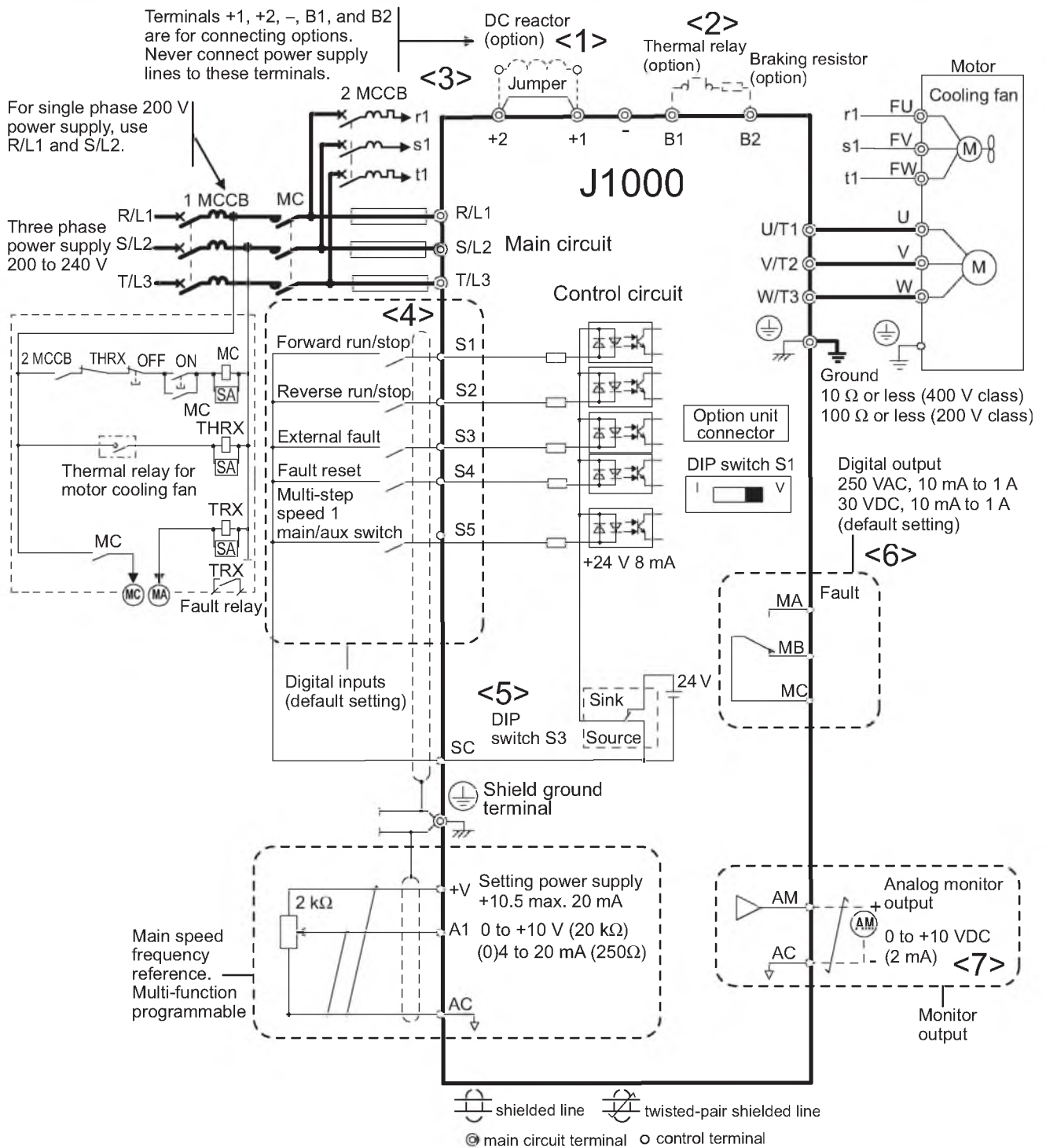

Main circuit

Terminal	Name	Function (signal level)
R/L1, S/L2, T/L3	Main circuit power supply input	Used to connect line power to the drive. Drives with single-phase 200 V input power use only terminals R/L1 and S/L2 (T/L3 is not connected to anything)
U/T1, V/T2, W/T3	Inverter output	Used to connect the motor
B1, B2	Braking resistor connection	Available for connecting a braking resistor or the braking resistor unit option.
+2, +1	DC reactor connection	Remove the short bar between +2 and +1 when connecting DC reactor (option)
+1, -	DC power supply input	For power supply input (+1: positive electrode; - : negative electrode)*
⊕	Grounding	For grounding (grounding should conform to the local grounding code.)



Control Circuit

Type	No.	Signal name	Function	Signal level
Digital input signals	S1	Multi-function input selection 1	Factory setting: runs when CLOSED, stops when OPEN.	24 VDC, 8 mA photocoupler insulation
	S2	Multi-function input selection 2	Factory setting: runs when CLOSED, stops when OPEN.	
	S3	Multi-function input selection 3	Factory setting: External Fault (N.O.)	
	S4	Multi-function input selection 4	Factory setting: Fault reset	
	S5	Multi-function input selection 5	Factory setting: Multi-step speed cmd 1	
	SC	Multi-function input selection Common	Common for control signal	
Analog input signal	FS	Power Supply for Frequency Setting	+10 V (allowable max current 20 mA)	
	FR1	Main Speed Freq Ref	Voltage input or current input 0 to +10 VDC (20 kΩ) (resolution 1/1000) 4 to 20 mA (250 Ω) or 0 to 20 mA (250 Ω) Resolution: 1/500	
	FC	Frequency reference common	0 V	
Digital output signals	MA	NO contact output	Factory setting: "fault"	Contact capacity 250 VAC, 1 A or less 30 VDC, 1 A or less
	MB	NC Output		
	MC	Relay Output common		
Analog output signals	AM	Analog monitor output	Factory setting: "output frequency" 0 to +10 V output Resolution: 1/1000	0 to 10 V 2 mA or less Resolution: 8 bits
	AC	Analog monitor common	0 V	

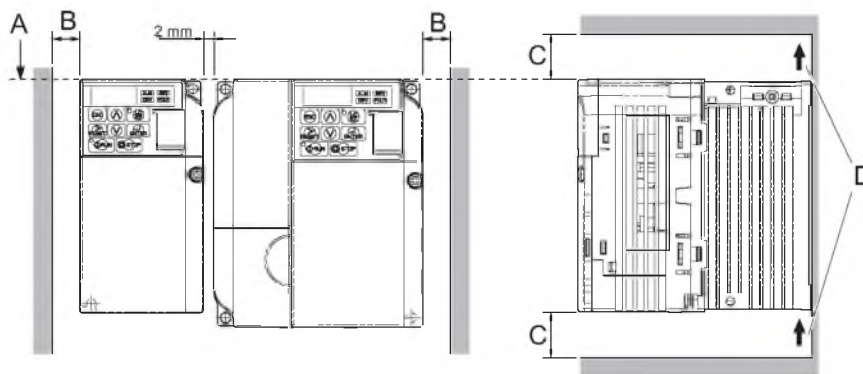

A- Line up the tops of the drives.

B- 30 mm minimum.

C - 100 mm minimum

D - Airflow direction

Inverter heat loss

Three-phase 200 V class

Model JZA		20P1	20P2	20P4	20P7	21P5	22P2	24P0
Inverter capacity kVA		0.3	0.6	1.1	1.9	3.0	4.2	6.7
Rated current (A) at HD		0.8	1.6	3	5	8	11	17.5
Rated current (A) at ND		1.2	1.9	3.5	6.0	9.6	12.0	21.0
Heat loss W HD	Fin	4.3	7.9	16.1	27.4	54.8	70.7	110.5
	Inside unit	7.3	8.8	11.5	15.9	23.8	30.0	43.3
	Total heat loss	11.6	16.7	27.7	43.3	78.6	100.6	153.8
Heat loss W ND	Fin	4.7	7.2	14.0	35.6	48.6	57.9	93.3
	Inside unit	7.9	9.4	13.4	16.9	25.0	29.6	45.0
	Total heat loss	12.6	16.6	28.5	43.1	73.6	87.5	138.2
Cooling Method		Self Cooled			Fan Cooled			

Single-phase 200 V class

Model JZA		B0P1	B0P2	B0P4	B0P7	B1P5
Inverter capacity kVA		0.3	0.6	1.1	1.9	3.0
Rated current (A) at HD		0.8	1.6	3	5	8
Rated current (A) at ND		1.2	1.9	3.5	6.0	9.6
Heat loss W HD	Fin	4.3	7.9	16.1	42.5	54.8
	Inside unit	7.4	8.9	11.5	19.0	25.9
	Total heat loss	11.7	16.7	27.7	61.5	80.7
Heat loss W ND	Fin	4.7	7.2	15.1	26.2	48.6
	Inside unit	8.4	9.6	14.3	20.8	29.0
	Total heat loss	13.1	16.8	28.3	56.5	77.6
Cooling Method		Self Cooled			Fan Cooled	

Three-phase 400 V class

Model JZA		40P2	40P4	40P7	41P5	42P2	43P0	44P0
Inverter capacity kVA		0.9	1.4	2.6	3.7	4.2	5.5	7.2
Rated current (A) at HD		1.2	1.8	3.4	4.8	5.5	7.2	9.2
Rated current (A) at ND		1.2	2.1	4.1	5.4	6.9	8.8	11.1
Heat loss W HD	Fin	19.2	28.9	42.3	70.7	81.0	84.6	107.2
	Inside unit	11.4	14.9	17.9	26.2	30.7	32.9	41.5
	Total heat loss	30.6	43.7	60.2	96.9	111.7	117.5	148.7
Heat loss W ND	Fin	8.2	15.5	26.4	37.5	49.7	55.7	71.9
	Inside unit	9.2	13.1	15.8	20.0	26.3	29.4	43.6
	Total heat loss	17.4	28.6	42.2	57.5	76.0	85.1	115.5
Cooling Method		Self Cooled			Fan Cooled			

Connections for braking resistor

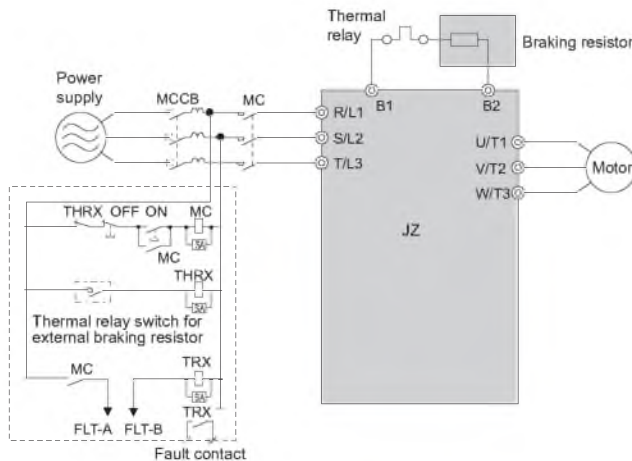

AC reactor

200 V class			400 V class		
Max. applicable motor output kW	Current value A	Inductance mH	Max. applicable motor output kW	Current value A	Inductance mH
0.12	2.0	2.0	-----		
0.25	2.0	2.0	0.2	1.3	18.0
0.55	2.5	4.2	0.4		
1.1	5	2.1	0.75	2.5	8.4
1.5	10	1.1	1.5	5	4.2
2.2	15	0.71	2.2	7.5	3.6
4.0	20	0.53	4.0	10	2.2

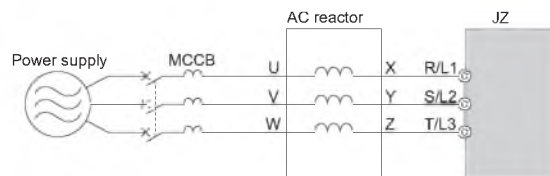

DC reactor

200 V class			400 V class		
Max. applicable motor output kW	Current value A	Inductance mH	Max. applicable motor output kW	Current value A	Inductance mH
0.12	5.4	8	-----		
0.25			0.2	3.2	28
0.55			0.4		
1.1			0.75		
1.5	18	3	1.5	5.7	11
2.2			2.2		
4.0			4.0	12	6.3

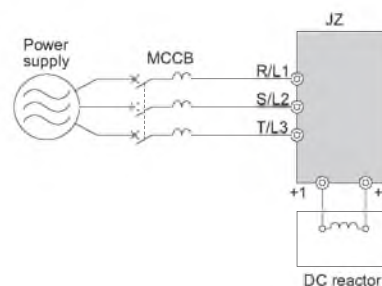

Ordering information

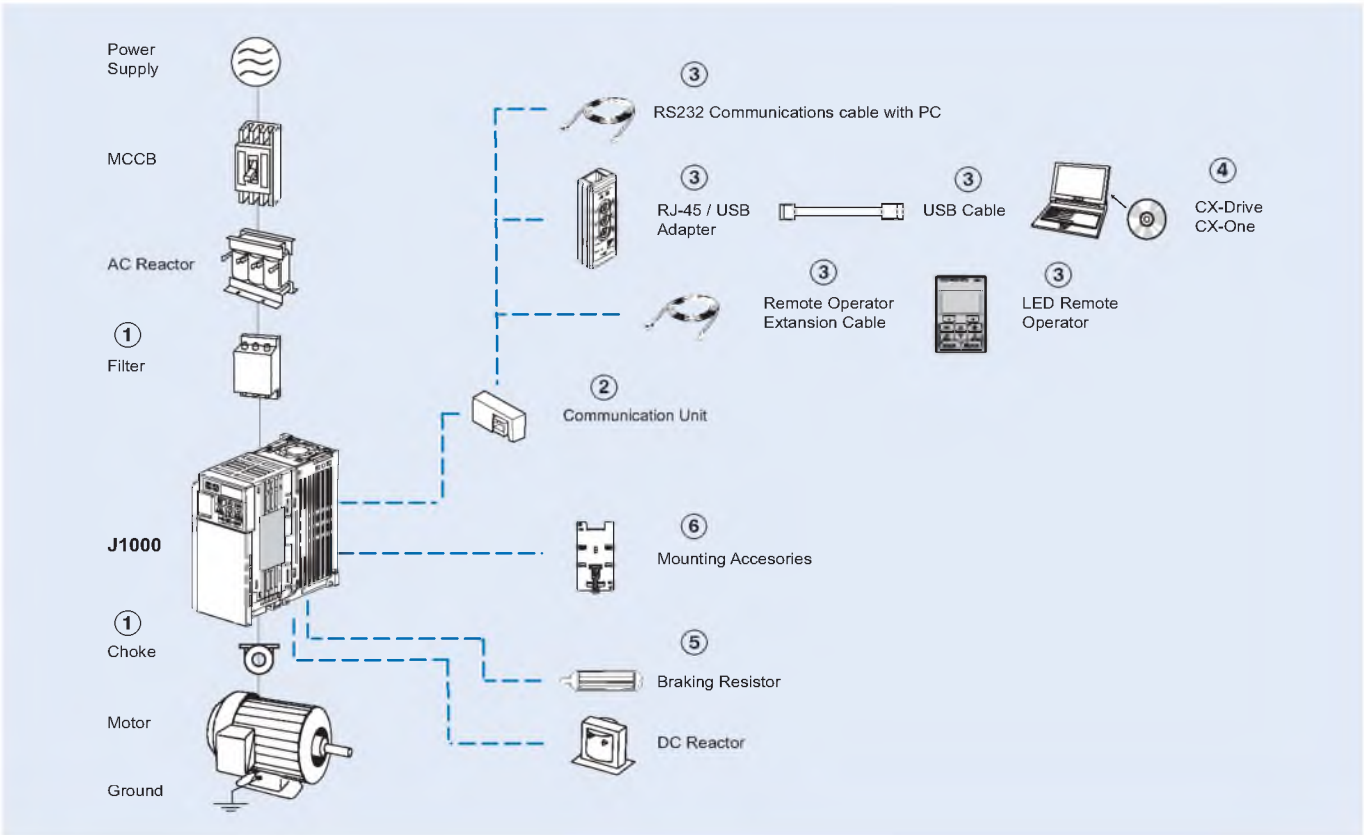

J1000

	Specifications				Model
	Heavy Duty		Normal Duty		Standard
1x200 V	0.12 kW	0.8 A	0.18 kW	0.8 A	JZAB0P1BAA
	0.25 kW	1.6 A	0.37 kW	1.6 A	JZAB0P2BAA
	0.55 kW	3.0 A	0.75 kW	3.5 A	JZAB0P4BAA
	1.1 kW	5.0 A	1.1 kW	6.0 A	JZAB0P7BAA
	1.5 kW	8.0 A	2.2 kW	9.6 A	JZAB1P5BAA
3x200 V	0.12 kW	0.8 A	0.18 kW	0.8 A	JZA20P1BAA
	0.25 kW	1.6 A	0.37 kW	1.6 A	JZA20P2BAA
	0.55 kW	3.0 A	0.75 kW	3.5 A	JZA20P4BAA
	1.1 kW	5.0 A	1.1 kW	6.0 A	JZA20P7BAA
	1.5 kW	8.0 A	2.2 kW	9.6 A	JZA21P5BAA
	2.2 kW	11.0 A	3.0 kW	12.0 A	JZA22P2BAA
	4.0 kW	17.5 A	5.5 kW	21.0 A	JZA24P0BAA
3x400 V	0.37 kW	1.2 A	0.37 kW	1.2 A	JZA40P2BAA
	0.55 kW	1.8 A	0.75 kW	2.1 A	JZA40P4BAA
	1.1 kW	3.4 A	1.5 kW	4.1 A	JZA40P7BAA
	1.5 kW	4.8 A	2.2 kW	5.4 A	JZA41P5BAA
	2.2 kW	5.5 A	3.0 kW	6.9 A	JZA42P2BAA
	3.0 kW	7.2 A	4.0 kW	8.8 A	JZA43P0BAA
	4.0 kW	9.2 A	5.5 kW	11.1 A	JZA44P0BAA

① Line filters

Inverter		Line filter Schaffner			Line filter Rasmi		
Voltage	Model JZA□	Reference	Rated current (A)	Weight (kg)	Reference	Rated current (A)	Weight (kg)
3-Phase 200 VAC	20P1 / 20P2 / 20P4 / 20P7	A1000-FIV2010-SE	10	0.7	A1000-FIV2010-RE	10	0.8
	21P5 / 22P2	A1000-FIV2020-SE	20	0.9	A1000-FIV2020-RE	20	1.1
	24P0	A1000-FIV2030-SE	30	1.0	A1000-FIV2030-RE	30	1.3
Single-Phase 200 VAC	B0P1 / B0P2 / B0P4	A1000-FIV1010-SE	10	0.5	A1000-FIV1010-RE	10	0.6
	B0P7 / B1P5	A1000-FIV1020-SE	20	0.7	A1000-FIV1020-RE	20	1.0
3-Phase 400 VAC	40P2 / 40P4	A1000-FIV3005-SE	5	0.5	A1000-FIV3005-RE	5	1.1
	40P7 / 41P5 / 42P2 / 43P0	A1000-FIV3010-SE	10	0.75	A1000-FIV3010-RE	10	1.1
	44P0	A1000-FIV3020-SE	15	1.0	A1000-FIV3020-RE	20	1.3

① Chokes

Model	Diameter	Description
A1000-FEV2102-RE	21	Recommended for motors below 2.2 KW
A1000-FEV2515-RE	25	Recommended for motors below 15 KW

② Communication cards

Type	Model	Description	Function
Option units	SI-232/JC	RS-232C serial communication interface	• RS232C communications interface to connect the drive to a PC or the optional copy unit
	SI-232/J	Remote operator interface	• RS232C communication interface for usage with the external LED operator JVOP-182
	SI-485/J	RS-422/485 Serial communications interface	• Interface for RS-422/485 communications using the MEMOBUS/ Modbus RTU protocol
	AI-V3/J	Potentiometer Option	• Potentiometer option for setting the frequency reference directly at the drive

② Accessories

Types	Model	Description	Functions
Digital operator	JVOP-182	LED remote operator	Remote operator with LED display and copy function, cable length max. 3m.
	A1000-CAVOP300-EE	Remote operator cable	3 meters cable for connecting remote operator
Accessories	JVOP-181	USB converter / USB cable	Allows the user to copy and verify parameter settings between drives. Can also be used as adapter to connect the drive to a PC USB port. SI-232/JC option is required
	A1000-CAVPC232-EE	PC connection cable	RS232 PC tool connection cable

④ Computer software

Types	Model	Description	Installation
Software	CX-drive	Computer software	Configuration and monitoring software tool
	CX-One	Computer software	Configuration and monitoring software tool

⑤ Braking unit, braking resistor unit

Voltage	Max. applicable motor output kW	Inverter		Connectable min. resistance Ω	Braking resistor unit						
		Inverter model JZA□			Inverter-mounted type (3 %ED, 10 sec max)						
		3-phase	1-phase		Type	Resistance Ω	No. of used	Braking torque %			
200 V (single-/ three-phase)	0.12	20P1	B0P1	300	A1000-REJ0K15400-IE	400	1	220			
	0.25	20P2	B0P2	300				220			
	0.55	20P4	B0P4	200				A1000-REJ0K15200-IE	200	1	220
	1.1	20P7	B0P7	120	125						
	1.5	21P5	B1P5	60	A1000-REJ0K15100-IE	100	1				125
	2.2	22P2	-	60	A1000-REJ0K15070-IE	70	1				120
	4.0	24P0	-	32	A1000-REJ0K15062-IE	62	1	100			
400 V (three-phase)	0.37	40P2	-	750	A1000-REJ0K10750-IE	750	1	230			
	0.55	40P4	-	750				230			
	1.1	40P7	-	510				130			
	1.5	41P5	-	240	A1000-REJ0K15400-IE	400	1	125			
	2.2	42P2	-	200	A1000-REJ0K15300-IE	300	1	115			
	3.0	43P0	-	100	A1000-REJ0K15400-IE	400	2	105			
	4.0	44P0	-								

⑥ Mounting accessories

Types	Model	Description	Applicable models JZA□
DIN Rail	EZZ08122A	Necessary to mount the inverter on a DIN rail	20P1/20P2/20P4/20P7 B0P1/B0P2/B0P4
	EZZ08122B		21P5/22P2 B0P7/B1P5 40P2/40P4/40P7/41P5/42P2
	EZZ08122C		24P0 B2P2 44P0
Heatsink external mounting attachment	100-034-075	Additional items to mount the inverter with the heatshink out of the panel.	20P1/20P2 B0P1/B0P2
	100-034-076		20P4 B0P4
	100-034-077		20P7
	100-034-078		40P2
	100-034-79		21P5/22P2 B1P5 41P5/42P2/43P0
	100-034-80		24P0 B2P2 44P0
	100-036-357		B4P0
	100-036-418		B0P7 40P4/40P7

ALL DIMENSIONS SHOWN ARE IN MILLIMETERS.  
 To convert millimeters into inches, multiply by 0.03937. To convert grams into ounces, multiply by 0.03527.

# ТЕХНИЧЕСКИЕ ХАРАКТЕРИСТИКИ

**По вопросам продаж и поддержки обращайтесь:**

Архангельск (8182)63-90-72  
Астана +7(7172)727-132  
Белгород (4722)40-23-64  
Брянск (4832)59-03-52  
Владивосток (423)249-28-31  
Волгоград (844)278-03-48  
Вологда (8172)26-41-59  
Воронеж (473)204-51-73  
Екатеринбург (343)384-55-89  
Иваново (4932)77-34-06  
Ижевск (3412)26-03-58  
Казань (843)206-01-48

Калининград (4012)72-03-81  
Калуга (4842)92-23-67  
Кемерово (3842)65-04-62  
Киров (8332)68-02-04  
Краснодар (861)203-40-90  
Красноярск (391)204-63-61  
Курск (4712)77-13-04  
Липецк (4742)52-20-81  
Магнитогорск (3519)55-03-13  
Москва (495)268-04-70  
Мурманск (8152)59-64-93  
Набережные Челны (8552)20-53-41

Нижний Новгород (831)429-08-12  
Новокузнецк (3843)20-46-81  
Новосибирск (383)227-86-73  
Орел (4862)44-53-42  
Оренбург (3532)37-68-04  
Пенза (8412)22-31-16  
Пермь (342)205-81-47  
Ростов-на-Дону (863)308-18-15  
Рязань (4912)46-61-64  
Самара (846)206-03-16  
Санкт-Петербург (812)309-46-40  
Саратов (845)249-38-78

Смоленск (4812)29-41-54  
Сочи (862)225-72-31  
Ставрополь (8652)20-65-13  
Тверь (4822)63-31-35  
Томск (3822)98-41-53  
Тула (4872)74-02-29  
Тюмень (3452)66-21-18  
Ульяновск (8422)24-23-59  
Уфа (347)229-48-12  
Челябинск (351)202-03-61  
Череповец (8202)49-02-64  
Ярославль (4852)69-52-93