

# Programmable Digital Controller **E5AR-T/E5ER-T**

One Digital Controller with  
 Up To 32 Programs



**По вопросам продаж и поддержки обращайтесь:**

Архангельск (8182)63-90-72  
 Астана +7(7172)727-132  
 Астрахань (8512)99-46-04  
 Барнаул (3852)73-04-60  
 Белгород (4722)40-23-64  
 Брянск (4832)59-03-52  
 Владивосток (423)249-28-31  
 Волгоград (844)278-03-48  
 Вологда (8172)26-41-59  
 Воронеж (473)204-51-73  
 Екатеринбург (343)384-55-89  
 Иваново (4932)77-34-06  
 Ижевск (3412)26-03-58  
 Иркутск (395) 279-98-46

Казань (843)206-01-48  
 Калининград (4012)72-03-81  
 Калуга (4842)92-23-67  
 Кемерово (3842)65-04-62  
 Киров (8332)68-02-04  
 Краснодар (861)203-40-90  
 Красноярск (391)204-63-61  
 Курск (4712)77-13-04  
 Липецк (4742)52-20-81  
 Магнитогорск (3519)55-03-13  
 Москва (495)268-04-70  
 Мурманск (8152)59-64-93  
 Набережные Челны (8552)20-53-41  
 Нижний Новгород (831)429-08-12

Новокузнецк (3843)20-46-81  
 Новосибирск (383)227-86-73  
 Омск (3812)21-46-40  
 Орел (4862)44-53-42  
 Оренбург (3532)37-68-04  
 Пенза (8412)22-31-16  
 Пермь (342)205-81-47  
 Ростов-на-Дону (863)308-18-15  
 Рязань (4912)46-61-64  
 Самара (846)206-03-16  
 Санкт-Петербург (812)309-46-40  
 Саратов (845)249-38-78  
 Севастополь (8692)22-31-93  
 Симферополь (3652)67-13-56

Смоленск (4812)29-41-54  
 Сочи (862)225-72-31  
 Ставрополь (8652)20-65-13  
 Сургут (3462)77-98-35  
 Тверь (4822)63-31-35  
 Томск (3822)98-41-53  
 Тула (4872)74-02-29  
 Тюмень (3452)66-21-18  
 Ульяновск (8422)24-23-59  
 Уфа (347)229-48-12  
 Хабаровск (4212)92-98-04  
 Челябинск (351)202-03-61  
 Череповец (8202)49-02-64  
 Ярославль (4852)69-52-93

Киргизия (996)312-96-26-47

Казахстан (772)734-952-31

Таджикистан (992)427-82-92-69

# A new High-speed, High-precision Digital Controller that is Programmable!

This Digital Controller boasts a sampling time of 50 ms, plus a resolution of 0.01°C for a Pt input.

And you can create up to 32 programs containing up to 256 segments total.

This type of performance makes a big difference in many applications, such as test equipment where many different settings must be tried.

- Create up to 32 programs with up to 256 segments total.
- Coordinated operation for up to four channels with one Digital Controller.
- 0.01°C; High resolution for Pt input.
- High-speed sampling at 50 ms.

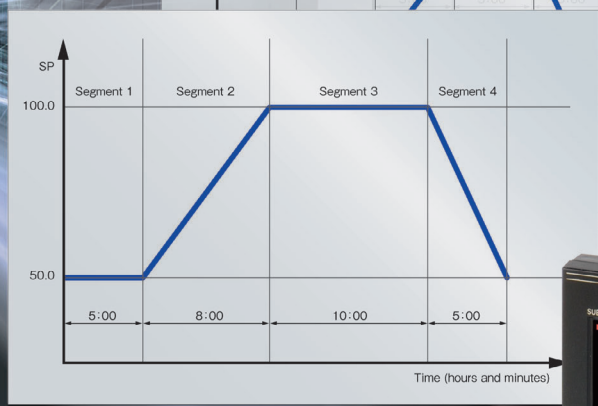
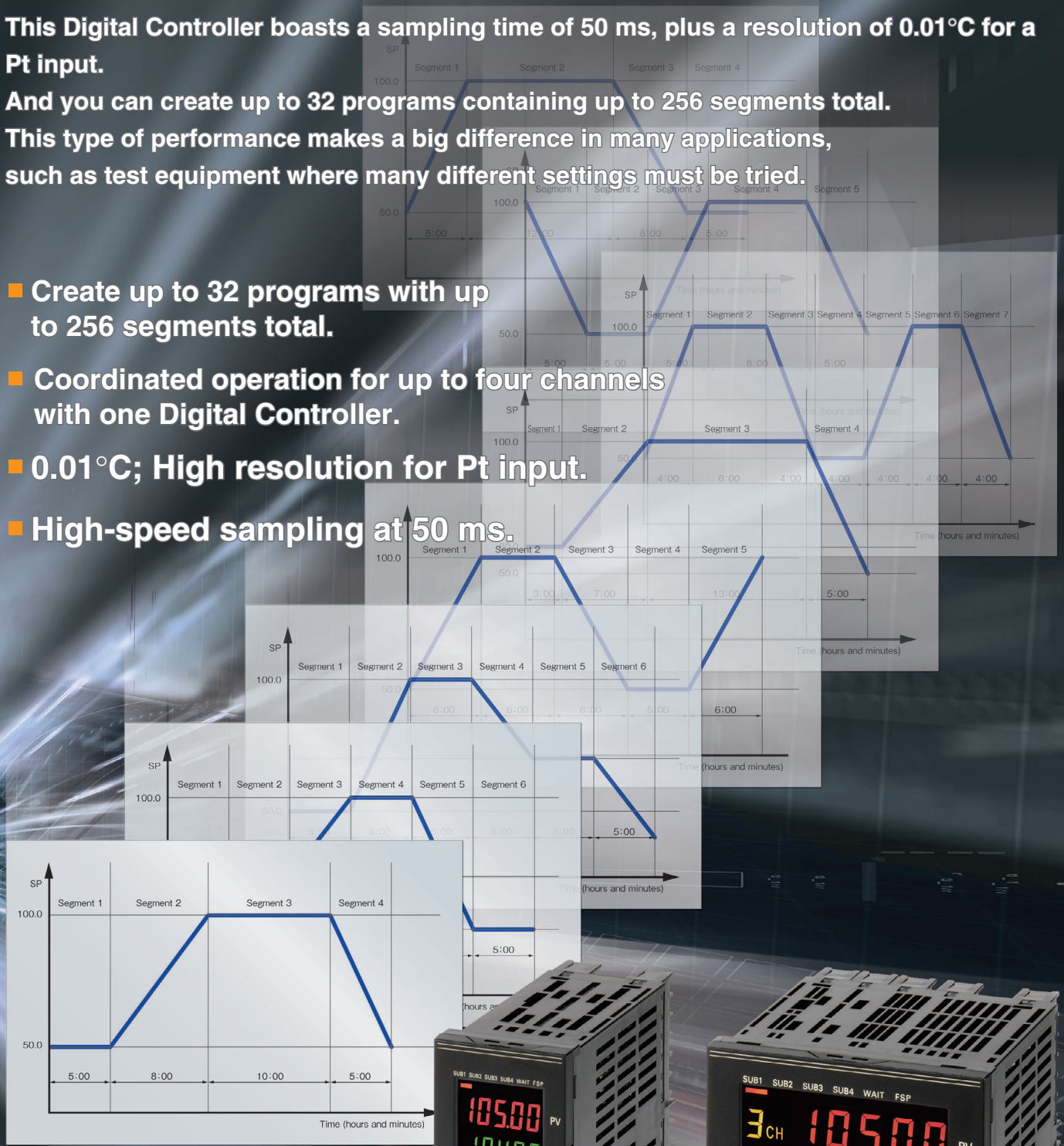

Programmable Digital Controller  
**E5AR-T/E5ER-T**

# Features

## Create Up To 32 Programs with Up To 256 Segments Total

You can create up to 32 programs with up to 8 segments each, or you can create up to 8 programs with up to 32 segments each. Either way, you get up to a total of 256 segments of programming. This feature is ideal for testing equipment to make a variety of settings.

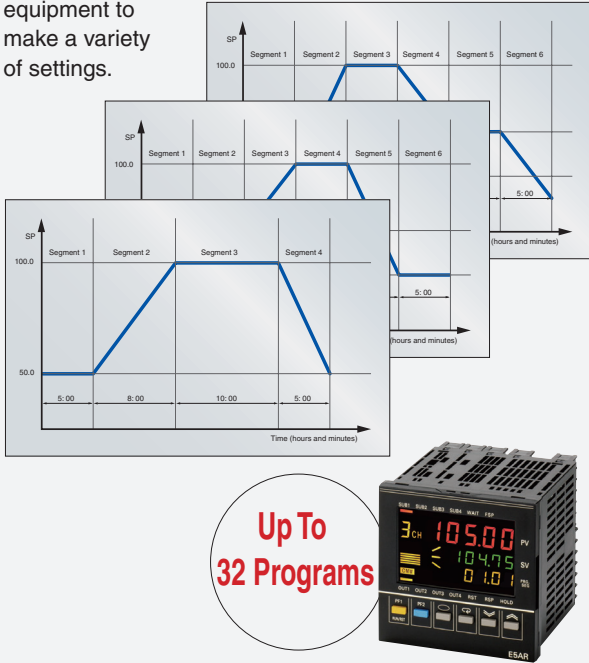

## High-speed and High-resolution Performance

Sample at the high speed of 50 ms for 4 channels to achieve stable control even for items requiring high-speed response. And, the resolution is 0.01°C for a Pt input. Temperature, humidity, and other factors for ambient testing equipment can be measured, variations detected, and data logged at a high resolution.

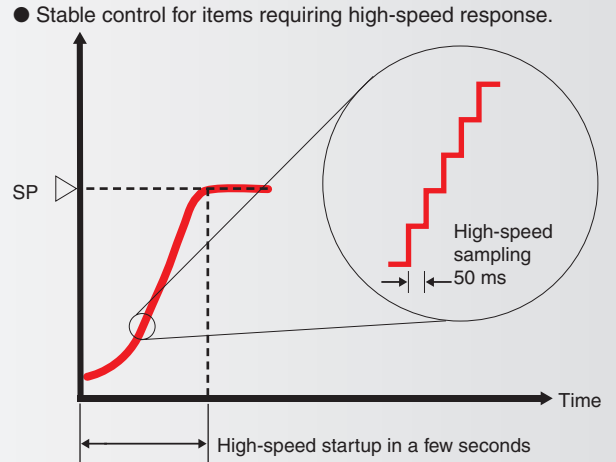

## Easy Settings from a Computer Using the CX-Thermo

The CX-Thermo setting software lets you set, edit, and transfer parameters all at once.

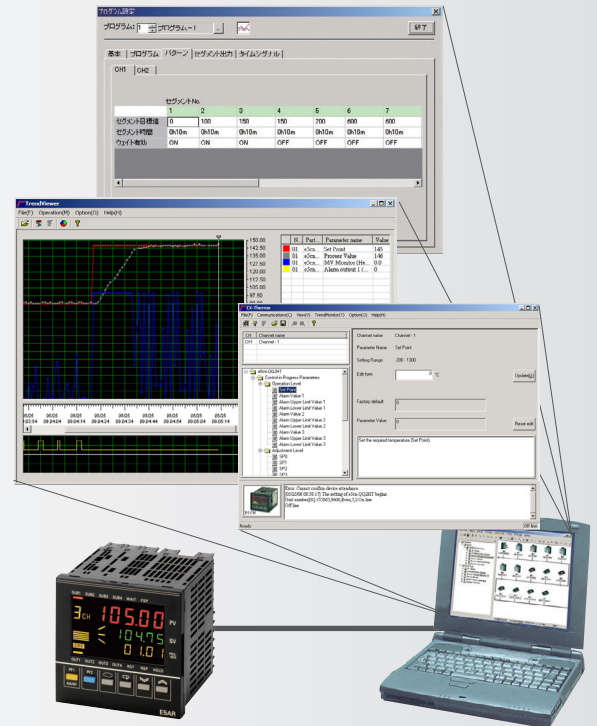

## Coordinated Operation for Up to Four Channels with One Digital Controller

Up to four channels are supported for analog control in a compact sized body to contribute to downsizing control panels.

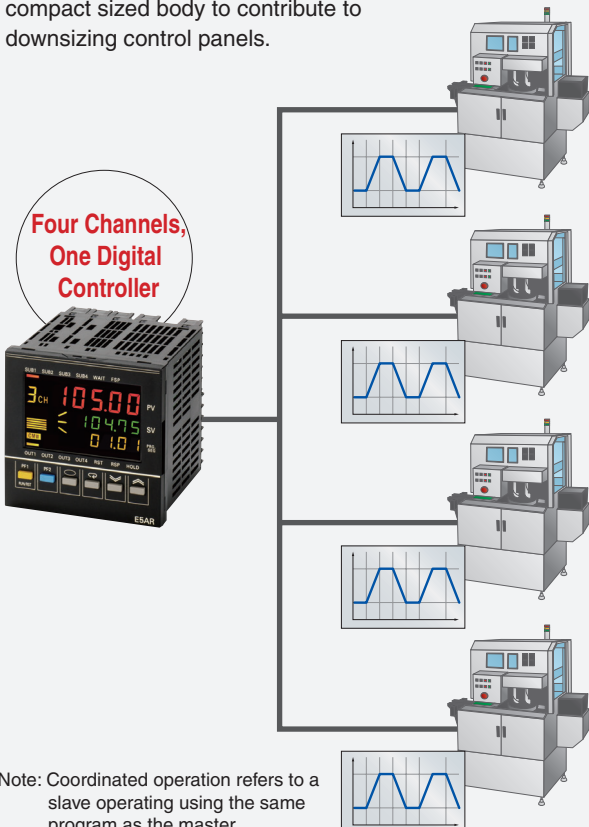

Note: Coordinated operation refers to a slave operating using the same program as the master.

## RoHS Compliance for World-wide Application

Available Soon

It will soon be possible to easily setup and monitor screens online using the SAP Library.

# Applications

## Semiconductor Test Equipment

**Topic** High-speed, high-precision programmed control

**Solution** Achieve optimum semiconductor temperature profiles with high-speed response and high precision.

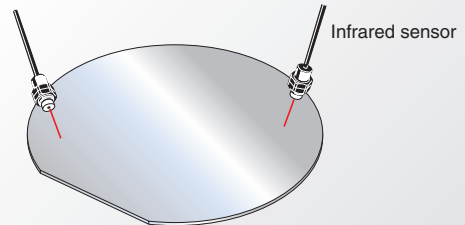
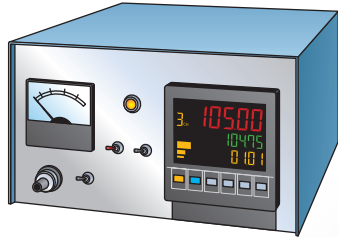

High Precision

Fast Response

Programmed Control

## Furnace Test Equipment

**Topic** High-speed heating and cooling control

**Solution** Use high-speed sampling to achieve repeated control for temperature increases and decreases of hundreds of degrees in a few second.

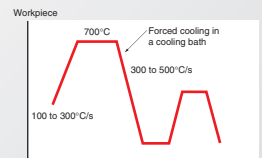
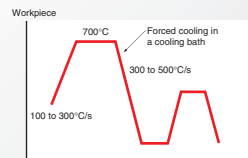
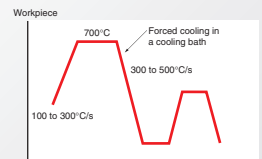
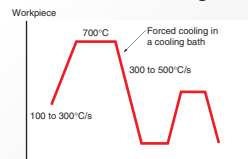
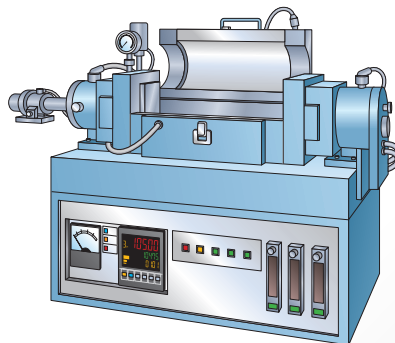

4 Channels

Coordinated Operation

Fast Response

Programmed Control

## Bonding Equipment

**Topic** Expensive, multifunctional controllers had to be used for devices requiring high-speed response, such as ceramic heaters, because economic temperature controllers were not available.

**Solution**

- Improved control performance with high-speed sampling (50 ms)
- Economic and easy to operate

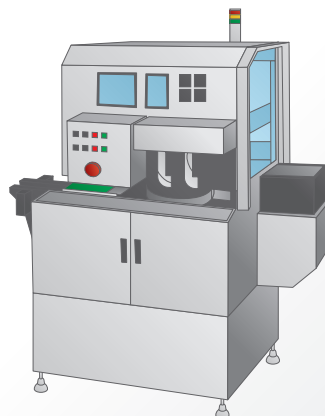

Fast Response

Programmed Control

# Ratings

Supply voltage (See note 2.)	CE marking	100 to 240 VAC, 50/60 Hz	24 VAC, 50/60 Hz; 24 VDC
	UL certification	100 to 120 VAC, 50/60 Hz	24 VAC, 50/60 Hz; 24 VDC
Operating voltage range		85% to 110% of rated supply voltage	
Power consumption		22 VA max. (with maximum load)	15 VA/10 W max. (with maximum load)
Sensor input (See note 3.)		Thermocouple: K, J, T, E, L, U, N, R, S, B, W Platinum resistance thermometer: Pt100 Current input: 4 to 20 mA DC, 0 to 20 mA DC (including remote SP input) Voltage input: 1 to 5 VDC, 0 to 5 VDC, 0 to 10 VDC (including remote SP input) (Input impedance: 150 Ω for current input, approx. 1 MΩ for voltage input)	
Control output	Voltage (pulse) output	12 VDC, 40 mA max. with short-circuit protection circuit (E5AR-TQQE3MW-FLK and E5AR-TQQE3MWW-FLK: 21 mA max.)	
	Current output	0 to 20 mA DC, 4 to 20 mA DC; load: 500 Ω max. (including transfer output) (Resolution: Approx. 54,000 for 0 to 20 mA DC; Approx. 43,000 for 4 to 20 mA DC)	
	Relay output	Position-proportional control type (open, closed) N.O., 250 VAC, 1 A (including inrush current)	
Auxiliary output		Relay Output: N.O., 250 VAC, 1 A (resistive load) Transistor Output: Maximum load voltage: 30 VDC; Maximum load current: 50 mA; Residual voltage: 1.5 V max.; Leakage current: 0.4 mA max.	
Potentiometer input		100 Ω to 2.5 kΩ	
Event input	Contact	Input ON: 1 kΩ max.; OFF: 100 kΩ min.	
	No-contact	Input ON: Residual voltage of 1.5 V max.; OFF: Leakage current of 0.1 mA max. Short-circuit: Approx. 4 mA	
Remote SP input		Refer to the information on sensor input.	
Transfer output		Refer to the information on control output.	
Control method		2-PID or ON/OFF control	
Setting method		Digital setting using front panel keys or setting using serial communications	
Indication method		7-segment digital display and single-lighting indicator Character Height E5AR: PV display: 12.8 mm; SV display: 7.7 mm; MV display: 7.7 mm, E5ER: PV display: 9.5 mm; SV display: 7.2 mm; MV display: 7.2 mm	
Other functions		Depends on model.	
Ambient operating temperature		-10 to 55°C (with no icing or condensation) For 3 years of assured use: -10 to 50°C (with no icing or condensation)	
Ambient operating humidity		25% to 85%	
Storage temperature		-25 to 65°C (with no icing or condensation)	

Note 1. Do not use an inverter output as the power supply.

2. The supply voltage (i.e., 100 to 240 VAC or 24 VAC/VDC) depends on the model. Be sure to specify the required type when ordering.

3. The Controller is equipped with multiple sensor input. Temperature input or analog input can be selected with the input type setting switch.

There is basic insulation between power supply and input terminals, power supply and output terminals, and input and output terminals.

# Program Control Functions

Number of programs (patterns)		32 (with 8 segments/program)
Number of segments (steps)		32 (with 8 programs)
Maximum number of segments		256
Segment setting method		Time setting (Segment set with target value and time.) Gradient setting (Segment set with target value, gradient, and time.)
Segment times		0 h 0 min to 99 h 59 min 0 min 0 s to 99 min 59 s 0 min 00.0 s to 99 min 59.9 s
Alarm group number specifications	Number of groups	4
	Setting method	Set separately for each program.
Reset operation		Select either stopping control or fixed SP operation.
Startup operation		Select continuing, resetting, manual operation, run mode, or ramp back operation.
PID groups	Number of groups	8
	Setting method	Set separately for each program (automatic PID group selection also supported).
Alarm SP function		Select from ramp SP and target SP.
Program status control	Segment operation	Advance, hold, and back
	Program operation	Program repetitions and program links
Wait operation	Wait method	Select from waiting at segment ends and always waiting.
	Wait width setting	Wait width upper limit and lower limit set separately for each program.
	Setting method	ON/OFF setting for each segment
Time signals	Number of outputs	6
	Number of ON/OFF operations	3 each per output
	Setting method	Set separately for each program.
Segment outputs	Number of outputs	10
	Setting method	ON/OFF set for each segment.
Program status output		Program end output (pulse width can be set) Segment number output
Program startup operation	PV start	Select from segment 1 target value, slope-priority PV start, and time-priority PV start.
	Standby	Standby
Operation end operation		Select from resetting, continuing control at final target value, and fixed SP control.
Number of event inputs		10 max.

# Ordering Information

Size	Control type	Control mode	Outputs (control/transfer)	Optional functions			Model	
				Auxiliary outputs (SUB)	Event inputs	Serial communications		
96 × 96 mm	Basic control (1 loop)	Standard control Heating and cooling control	2 (pulse + pulse/current)	4	2	None	E5AR-TQ4B	
			2 (current + current)				E5AR-TC4B	
			2 (pulse + pulse/current)				E5AR-TQ43B-FLK*	
			2 (current + current)				E5AR-TC43B-FLK*	
			2 (pulse + pulse/current)				RS-485	E5AR-TQE3MB-FLK*
			2 (current + current)				E5AR-TCE3MB-FLK*	
	2-loop control	2-loop standard control Single-loop heating and cooling control Single-loop cascade control Single-loop control with remote SP Single-loop proportional control	2 (pulse + pulse/current)	4	4	RS-485	E5AR-TQ43DW-FLK*	
			2 (current + current)				E5AR-TC43DW-FLK*	
			4 (2 pulse + 2 pulse/2 current)				E5AR-TQQE3MW-FLK	
	4-loop control	4-loop standard control 2-loop heading cooling control (See note 3.)	4 (4 current)	10 (See note 2.)	8	RS-485	E5AR-TCCE3MWW-FLK	
			4 (2 pulse + 2 pulse/2 current)				E5AR-TQQE3MWW-FLK*	
	Control valve control (1 loop)	Single-loop position-proportional control	Relay outputs (1 open, 1 closed)	4	4	None	E5AR-TPR4DF	
Relay outputs (1 open, 1 closed) + 1 current			10 (See note 2.)	8	RS-485	E5AR-TPRQE3MF-FLK		
48 × 96 mm	Basic control (1 loop)	Standard control Heating and cooling control	2 (pulse + pulse/current)	4	2	None	E5ER-TQ4B	
			2 (current + current)				E5ER-TC4B	
			2 (pulse + pulse/current)				RS-485	E5ER-TQC43B-FLK
	2-loop control	2-loop standard control Single-loop heating and cooling control Single-loop cascade control Single-loop control with remote SP Single-loop proportional control	2 (pulse + pulse/current)	2 (See note 2.)	4	RS-485	E5ER-TQT3DW-FLK	
			2 (current + current)				E5ER-TCT3DW-FLK	
	Control valve control (1 loop)	Single-loop position-proportional control	Relay outputs (1 open, 1 closed)	2 (See note 2.)	4	None	E5ER-TPRTDF	
			Relay outputs (1 open, 1 closed) + 1 current	4	None	RS-485	E5ER-TPRQ43F-FLK	

Note 1. Specify the power supply specifications when ordering. Model numbers for 100 to 240 VAC are different from those for 24 VAC/VDC.

\*Models marked with asterisks are available only for 100 to 240 VAC.

2. The outputs are transistor outputs.

3. Only for coordinated operation. (A different program cannot be set for each channel.)

- The application examples provided in this catalog are for reference only. Check functions and safety of the equipment before use.
- Never use the products for any application requiring special safety requirements, such as nuclear energy control systems, railroad systems, aviation systems, medical equipment, amusement machines, vehicles, safety equipment, or other application involving serious risk to life or property, without ensuring that the system as a whole has been designed to address the risks, and that the OMRON products are properly rated and installed for the intended use within the overall equipment or system.

## По вопросам продаж и поддержки обращайтесь:

Архангельск (8182)63-90-72  
Астана +7(7172)727-132  
Астрахань (8512)99-46-04  
Барнаул (3852)73-04-60  
Белгород (4722)40-23-64  
Брянск (4832)59-03-52  
Владивосток (423)249-28-31  
Волгоград (844)278-03-48  
Вологда (8172)26-41-59  
Воронеж (473)204-51-73  
Екатеринбург (343)384-55-89  
Иваново (4932)77-34-06  
Ижевск (3412)26-03-58  
Иркутск (395) 279-98-46

Казань (843)206-01-48  
Калининград (4012)72-03-81  
Калуга (4842)92-23-67  
Кемерово (3842)65-04-62  
Киров (8332)68-02-04  
Краснодар (861)203-40-90  
Красноярск (391)204-63-61  
Курск (4712)77-13-04  
Липецк (4742)52-20-81  
Магнитогорск (3519)55-03-13  
Москва (495)268-04-70  
Мурманск (8152)59-64-93  
Набережные Челны (8552)20-53-41  
Нижний Новгород (831)429-08-12

Новокузнецк (3843)20-46-81  
Новосибирск (383)227-86-73  
Омск (3812)21-46-40  
Орел (4862)44-53-42  
Оренбург (3532)37-68-04  
Пенза (8412)22-31-16  
Пермь (342)205-81-47  
Ростов-на-Дону (863)308-18-15  
Рязань (4912)46-61-64  
Самара (846)206-03-16  
Санкт-Петербург (812)309-46-40  
Саратов (845)249-38-78  
Севастополь (8692)22-31-93  
Симферополь (3652)67-13-56

Смоленск (4812)29-41-54  
Сочи (862)225-72-31  
Ставрополь (8652)20-65-13  
Сургут (3462)77-98-35  
Тверь (4822)63-31-35  
Томск (3822)98-41-53  
Тула (4872)74-02-29  
Тюмень (3452)66-21-18  
Ульяновск (8422)24-23-59  
Уфа (347)229-48-12  
Хабаровск (4212)92-98-04  
Челябинск (351)202-03-61  
Череповец (8202)49-02-64  
Ярославль (4852)69-52-93

Киргизия (996)312-96-26-47

Казахстан (772)734-952-31

Таджикистан (992)427-82-92-69

Эл. почта: [orm@nt-rt.ru](mailto:orm@nt-rt.ru) || Сайт: <http://omron.nt-rt.ru>